



Installation Instruction BOCR 4.0 C1 Motor Protection Relay

Thank you for purchasing the BCH BOCR 4.0 C1 Relay

SAFETY PRECAUTIONS

Be sure to read the instruction manual and safety precautions before use products.

 **Warning** : Failure to comply with this message may result in damage to the device or system.

 **Caution** : Incorrect handling of the device may result in damage to the device or system.

Caution

- Change in setting is possible only in motor stop state and there should not be any fault with appropriate password. Default password is four times Enter Key.
- Keep the product in the place where is no humidity and dust.
- Please check the phase & polarity while inserting the CT wire.
- Wrong polarity or phase can cause the wrong result (may cause Phase Reversal / Unbalance / Earth Fault).
- The product which is different from order may cause damage to the device or system.
- Installation, maintenance and inspection of the product should be performed by the qualified engineers.
- Wire the terminal after confirming the terminal number, It may cause the damage or fire.
- Recommended to use BCH supplied CBCT only.

Warning

- Do not change the setting during motor running.
- Turn off the upstream breaker before installing or service to prevent electric shocks & burn due to short circuit.

BOCR 4.0 C1

Overview

The Installation Instruction provides step-by-step instructions for the installation and setup of BOCR 4.0 C1 series motor protection relay, helping users get the system set up and running as quickly as possible. This guide contains only basic information required to operate the relay.

General Description

BOCR 4.0 C1 series motor protection relay is a micro controller based relay designed for protection of LV & MV motors. It is equipped with 3 output relays for trip and alarm. Following are the brief description:-

Parameter	Description
Operational Current	For 60A model (0.5 - 8.0 x IFL) & For 5A model (0.05 - 10.0 X IFL)
Frequency Range	50 / 60 Hz
Accuracy	
Trip Time	+ 5% (or + 100 mSec) (which ever is higher)
Trip Current (Phase)	+ 5% (or + 0.020 Amp) (which ever is higher)
Trip Current (Earth)	+ 5% (or + 0.020 Amp) (which ever is higher)
Display	LED Type
Analog Output (4-20mA)*	Max Load Resistance 300 Ω
Auxilliary Supply <small>(Refer Ordering Information)</small>	85V to 280V AC/DC
Contact Rating	
DO Contact	1C/O + 2NO: 5A@ 250 VAC/24VDC
Earth Current	For 05A model (0.05 - 2.50) & For 60A model (0.5 - 30.00)
DO Reset	Automatic / Manual / Electric
DI Input	Active: 40-160V DC (L model) / 85-260V AC (H model)
Mounting	35 mm Din-rail / Panel mount
Temperature Operation	0°C to 70°C
Temperature Storage	-10°C to 85°C
Wiring Connection	
For current	Penetration / Tunnel Type
For Others <small>(Aux sup, Relay contact etc.)</small>	Screwed Terminal

NOTE :

- *Model Dependant

Ordering Information

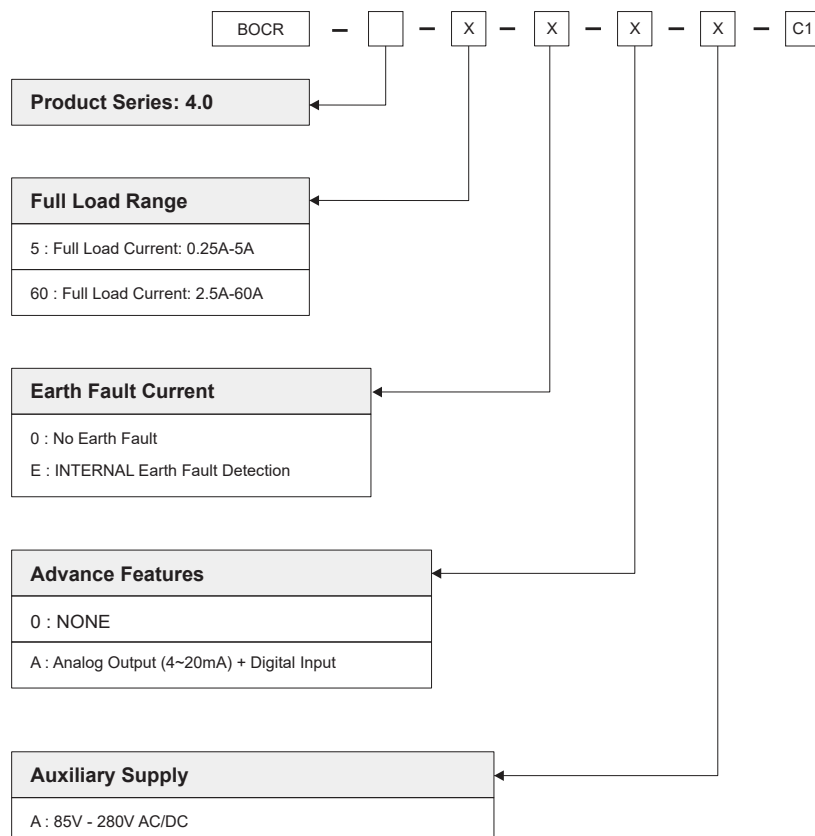

BOCR 4.0 C1

Front Interface

Display Module

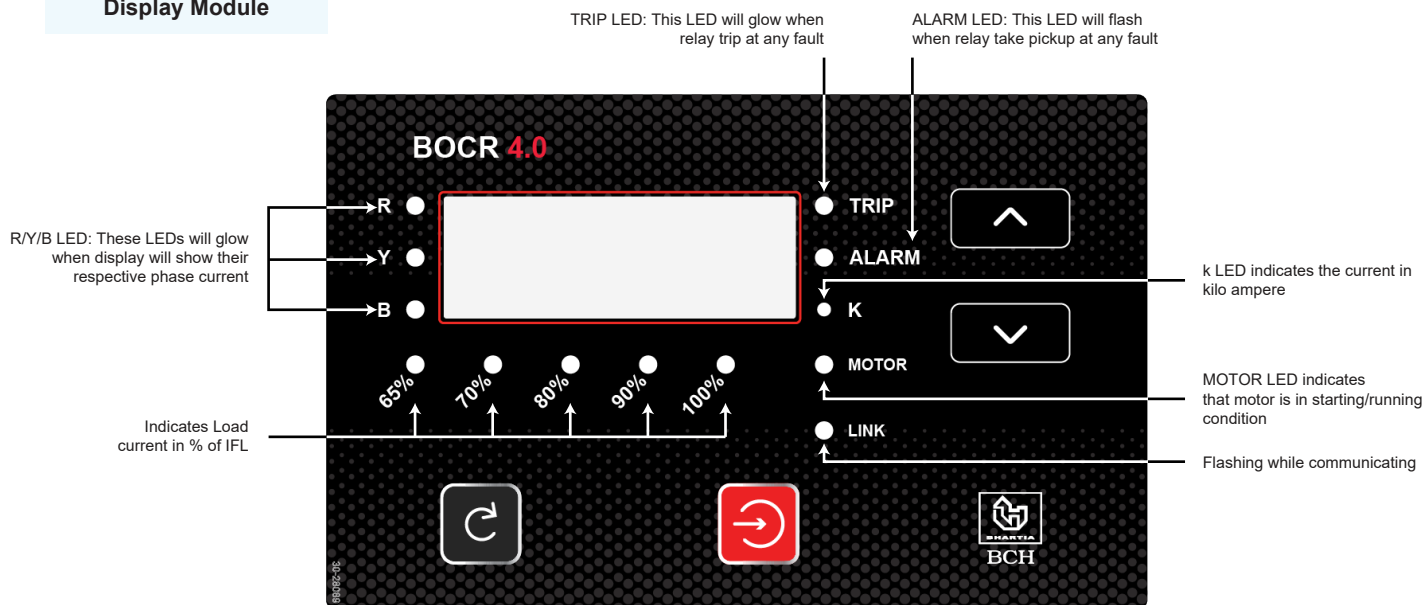

BASE Module

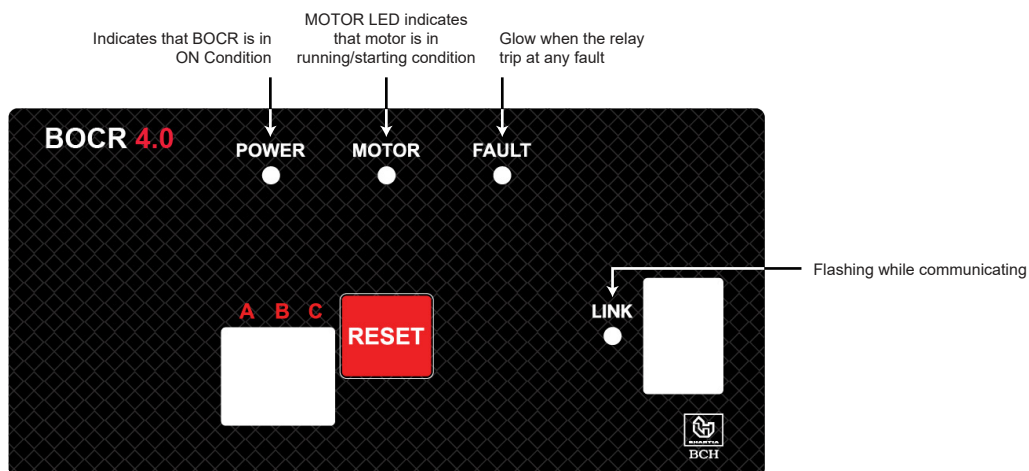

- Motor State Indicator: Flashing of RUN LED for Motor Start & glowing steady of RUN LED for run condition.

Keys	Description
	Used as ENTER key in Edit / Setting / View menu
	Used as scroll key / increment key
	Used as scroll key / decrement key
	Used for Fault Reset
	Used to Exit from any Setting Menu Long Press for Fault Reset

BOCR 4.0 C1

Terminal Description

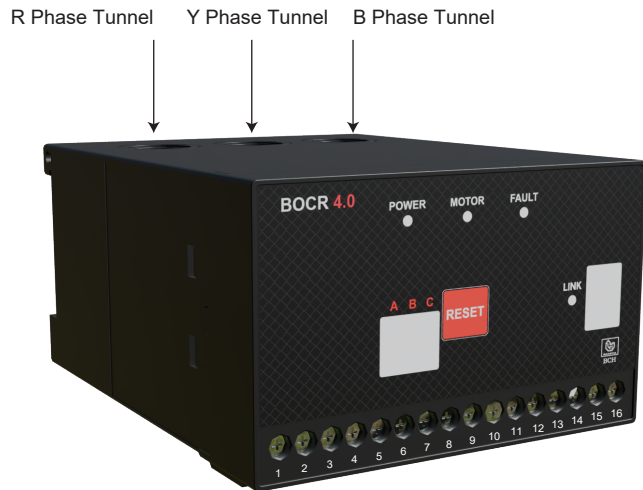

BOCR Terminal Function	
Terminal No.	Description
1	AUX-CONTROL INPUT -L
2	X
3	AUX-CONTROL INPUT -N
4	RLY1-COM
5	RLY1-NO
6	RLY1-NC
7	RLY2-COM
8	RLY2-NO
9	RLY3-COM
10	RLY3-NO
11	DI-L*
12	DI-N*
13	X
14	X
15	X
16	X
A	Analog Output*
B	
C	X

NOTE :

- *Model dependant
- Wire cross section : 2.5 mm²
- Torque : 0.4Nm - 0.6Nm
- Screw Thread : M3

Dimension Details

Display Module

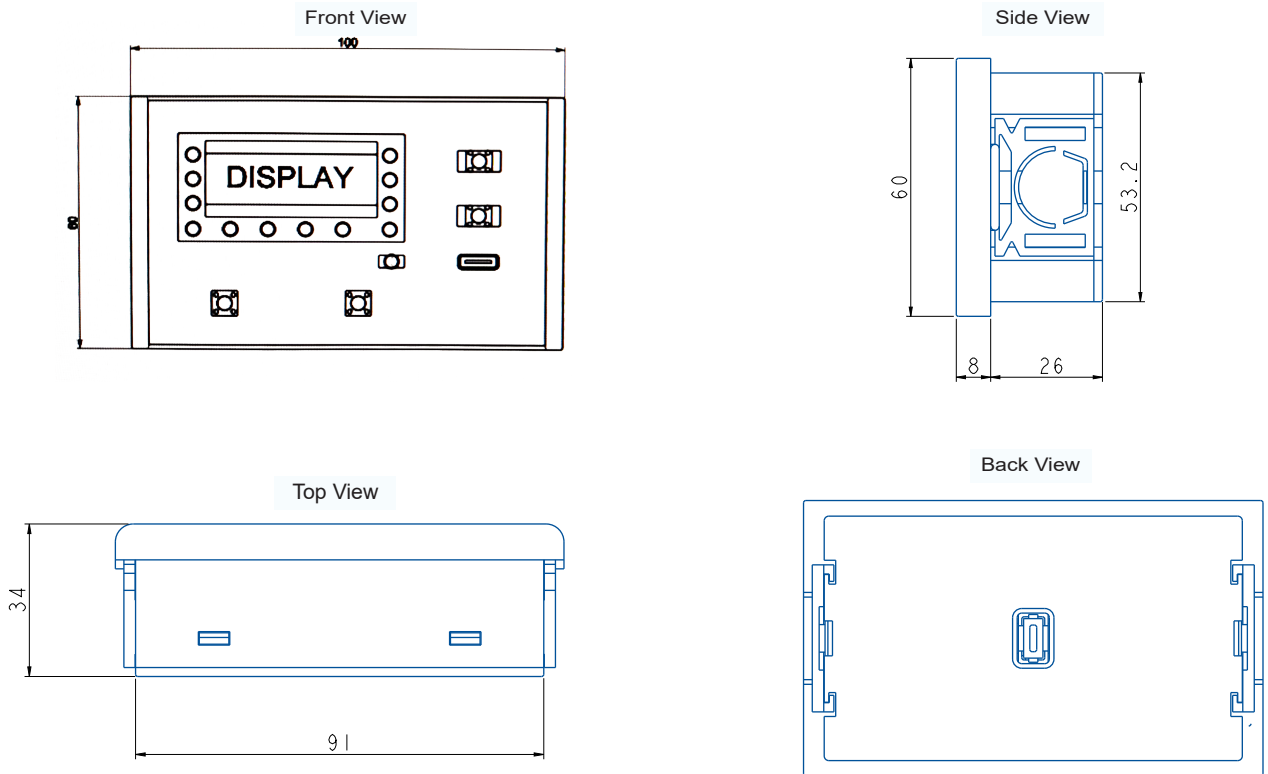

Base Module

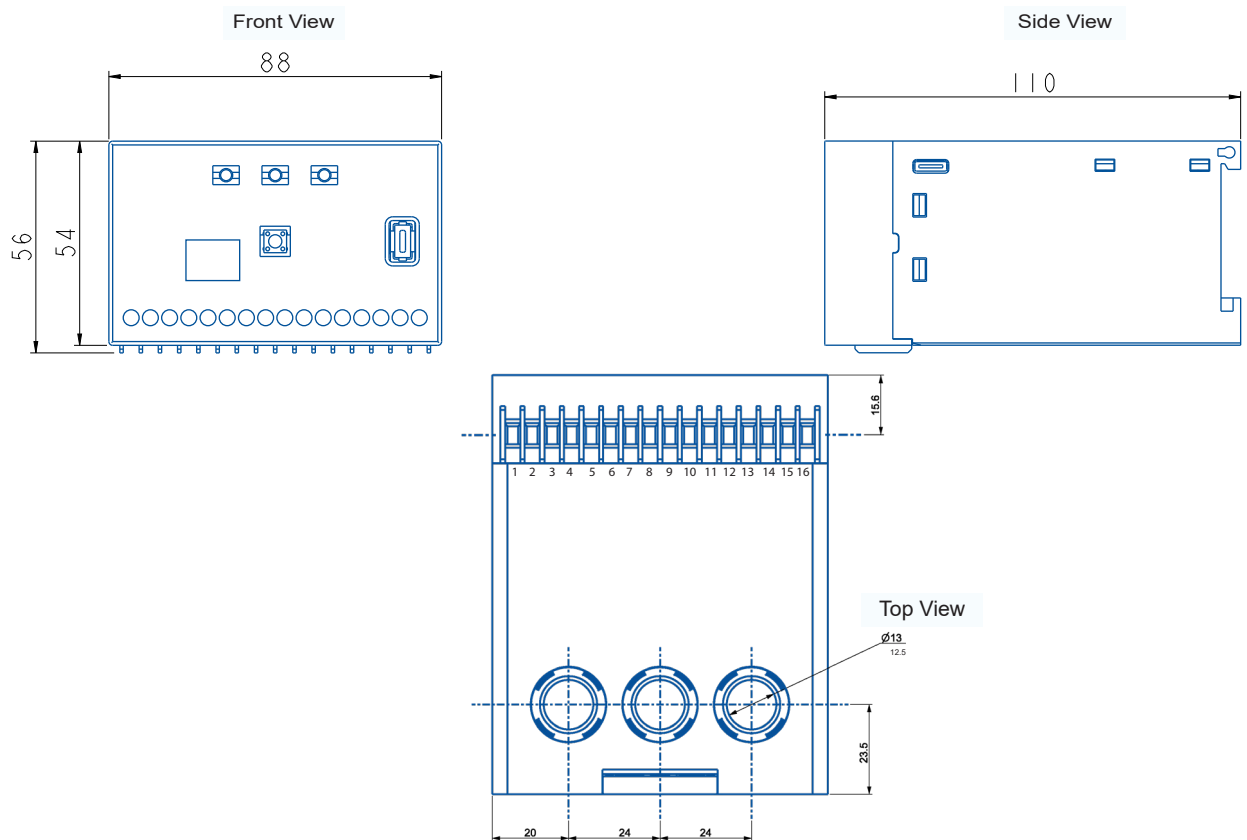

BOCR 4.0 C1

Connection Diagram

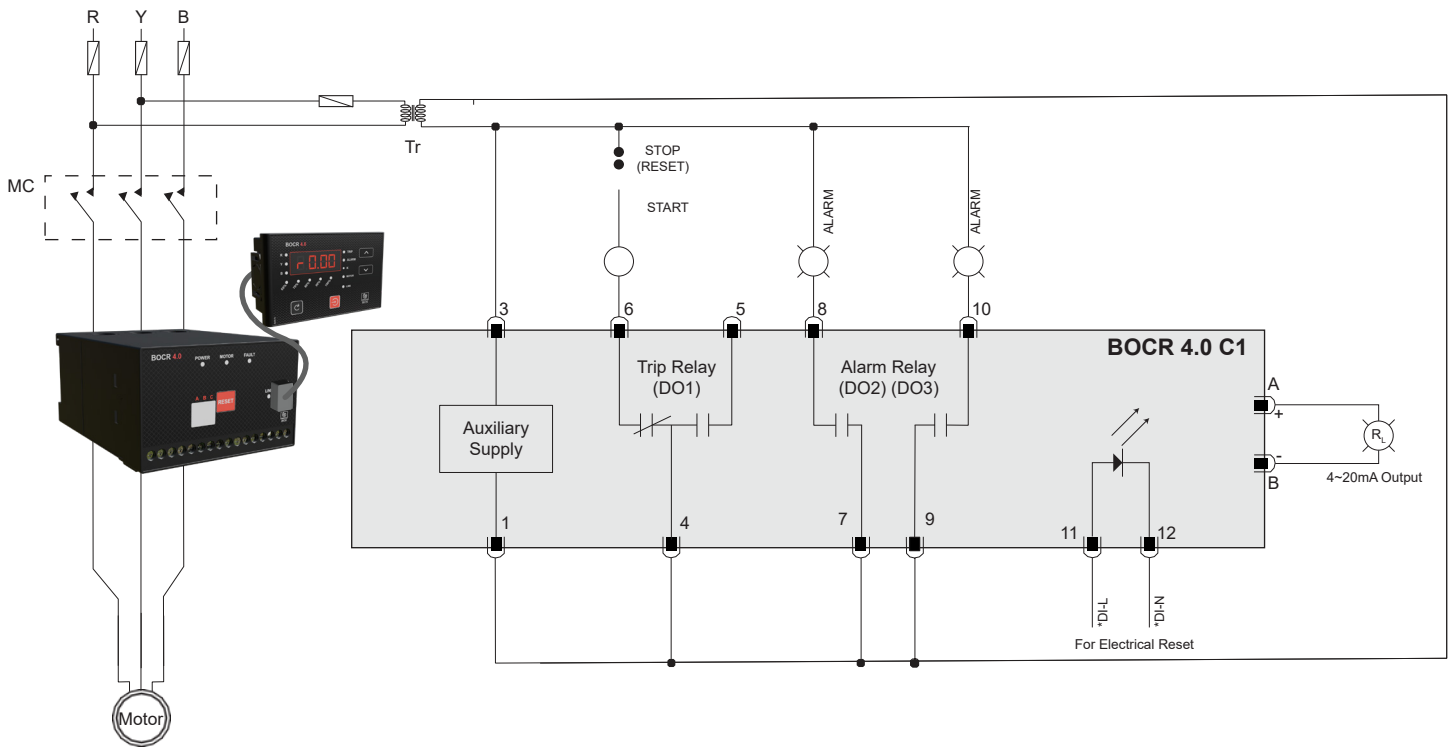

BOCR 4.0 C1 typical connection diagram

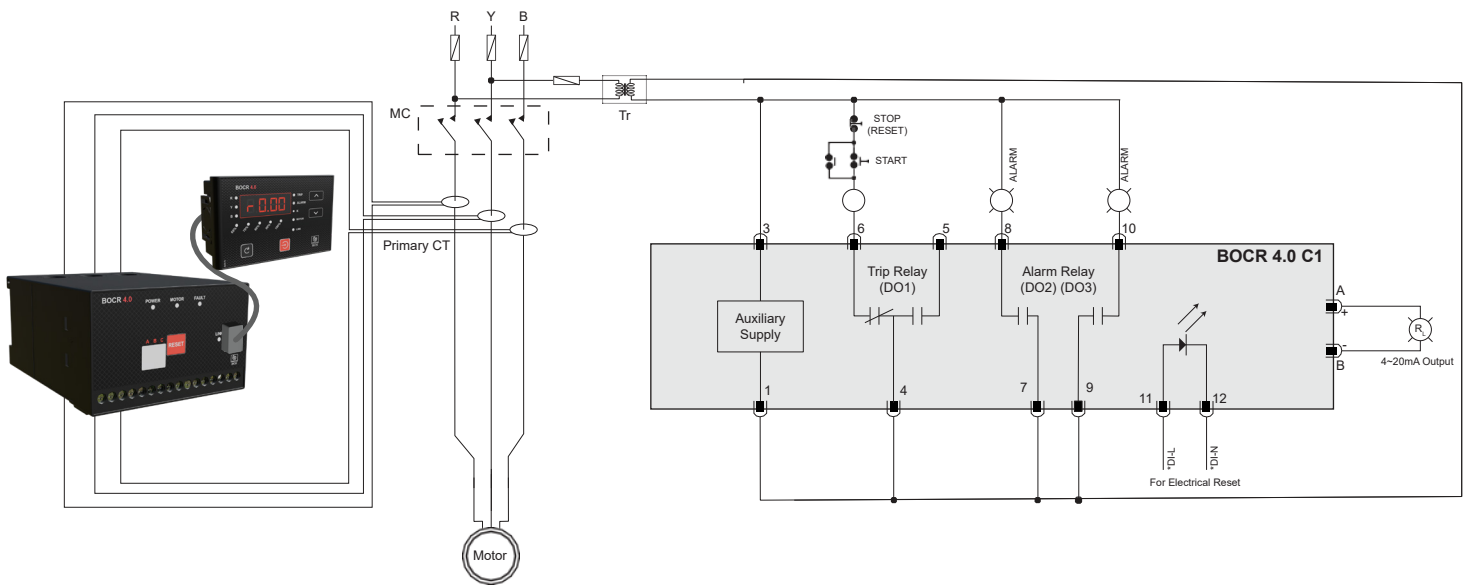

BOCR 4.0 C1 with External Primary CT

Setting Parameters Common Setting Parameters

Parameter	4 Digit Short Name	Setting Range		Step Size	Unit	Default Setting
		Min.	Max.			
Full Load Current ⁽¹⁾	<i>1.IFL</i>	2.5 ⁽¹⁾ /0.25 ⁽²⁾	60.00 ⁽¹⁾ / 5.00 ⁽²⁾	0.01	Amp	60/5
External CT Ratio ⁽³⁾	<i>2.CTr</i>	1	999	1	-	1
DO Reset <small>(ATO: Auto, MAN: Manual, REM: Remote)</small>	<i>3.RMS</i>	AUTO / MANUAL / ELECTRIC		-	-	MAN
Motor start time	<i>4.NSt</i>	1	200	1	Sec	8
Thermal Memory Reset <small>(Enable: ON, Disable: OFF)</small>	<i>5.Lhr</i>	OFF	ON	-	-	OFF
DO Fail Safe Mode <small>(Enable: ON, Disable: OFF)</small>	<i>6.FSR</i>	OFF	ON	-	-	ON
Analog Output (4~20mA) ^{(4)*}	<i>7.Ano</i>	$I_r / I_y / I_b / I_{max} / I_{ub} / OFF$		-	-	OFF

NOTE :

- 60A Model.
- 5A Model.
- CT ratio parameter will come into picture only when external primary CT is used.
- 4~20mA range is proportional to 0%~100% of (I_r / I_y / I_b / I_{max} or I_{ub}) IFL only.

DO Matrix

BOCR 4.0 C1 provides 3 configurable potential free DO output for breaker operations hooter, flashing signal as action to a fault condition.

A typical example of the DO fault assignment matrix is provided below.

Fault Protection	DO Output		
	DO1	DO2	DO3
Short Circuit Protection	1		3
Overload Protection	1		
Earth fault Protection		2	
Load Unbalance			
Phase Reversal		2	
Lock Rotor	1		
Stall	1		
Under Current			
Phase Loss			3
CB Fail			3

As per the above example, DO1 will operate for Short Circuit, Overload, Stall Rotor and Locked Rotor Fault Condition. DO3 will also operate in Short Circuit Condition along with Phase Loss and CB Fail Condition. DO2 will operate for Earth Fault and Phase reversal Fault only. Similarly user can apply maximum all three DOs for all the faults.

Analog Output*

The **4–20 mA output signal** is widely used in protection devices because it provides a reliable and standardized way to transmit analog data to external systems such as controllers, PLCs, or monitoring equipment. This current loop is highly immune to electrical noise and voltage drops, making it ideal for long-distance communication in industrial environments. The range also allows for easy fault detection—any signal below 4 mA indicates a wiring or sensor failure. By using 4–20 mA, BOCR 4.0 C1 can seamlessly interface with the external world for accurate monitoring and control.

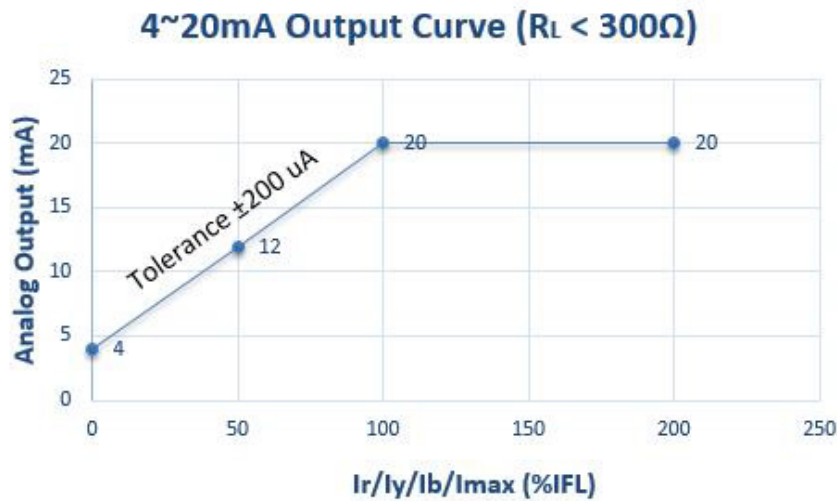

Digital Input*

BOCR 4.0 C1 provides digital input to operate the device remotely. The DI is configured for remote reset. For any fault condition if the relay reset is configured as “Remote Reset”. Then, only in that case the users are allowed to reset the relay remotely from control room. This feature is useful for convenient way of restoring power with supervision.

NOTE :

- *Model Dependant

Protections Setting Parameter

Parameter	4 Digit Short Name	Setting Range		Step Size	Unit	Default Setting
		Min.	Max.			
Thermal Characteristics	1.DLC	DEFT	THERM	-	-	THERM
Over-load Pickup Level	2.OLP	50	150	1%	% IFL (Amp)	110%
Over-load Definite Time	3.OLD	0.1	30.0	0.1	Sec	10
Thermal Class	4.DLE	1	30	1	-	10
Short Circuit Pickup	5.SCP	200	800 ⁽¹⁾ /1000 ⁽²⁾	50%	% IFL (Amp)	500%
Short Circuit Trip Time	6.SCT	0.05	1.0	0.01	Sec	0.5
Earth Fault Pickup	7.EFP	0.05 ⁽²⁾ /0.5 ⁽¹⁾	2.5 ⁽²⁾ /30 ⁽¹⁾	0.01	Amp	OFF
Earth Fault Trip Time	8.EFT	0.05	10	0.01	Sec	1
Under-Load Pickup	9.UCP	20	90	5%	% IFL (Amp)	OFF
Under-Load Trip Time	1.UCT	1.0	30.0	0.1	Sec	3
Unbalance Current Pickup	2.PUP	5	50	2.5%	% IFL (Amp)	OFF
Unbalance Current Trip Time	3.PUT	1	30	1	Sec	3
Locked Rotor Pickup	4.LrP	200	800 ⁽¹⁾ /1000 ⁽²⁾	50%	% IFL (Amp)	800%
Locked Rotor Trip Time	5.LrT	5.0	20.0	0.1	Sec	5 sec
Stall Rotor Pickup	6.StP	150	800	5%	% IFL (Amp)	OFF
Stall Rotor Trip Time	7.StT	0.5	10	1	Sec	3

Advance Setting Parameters

Parameter	4 Digit Short Name	Setting Range		Step Size	Unit	Default Setting
		Min.	Max.			
Phase Loss Trip Time	1.PLT	0.5	5.0	0.1	Sec	OFF
Phase Reversal Trip	2.Phr	OFF	ON	-	-	OFF
Contactora Fail Detection Time	3.Cbt	0.1	10	0.1	Sec	0.5
Earth Fault Selection	4.LES	Run	Start + Run	-	-	Start + Run

NOTE :

- All above protection are available with disable option (OFF) & in % of IFL.
- BOCR 4.0 C1 will allow settings to be changed only when the motor is in a stopped, non-faulty condition and no fault has been detected.
- ⁽¹⁾ 60A Model.
- ⁽²⁾ 5A Model.

Human Machine Interface Navigation

Navigation and editing of the HMI are performed by using the Scroll Keys, Exit Key and Enter keys to switch between screens



MAIN SCREENS



MENU SCREEN

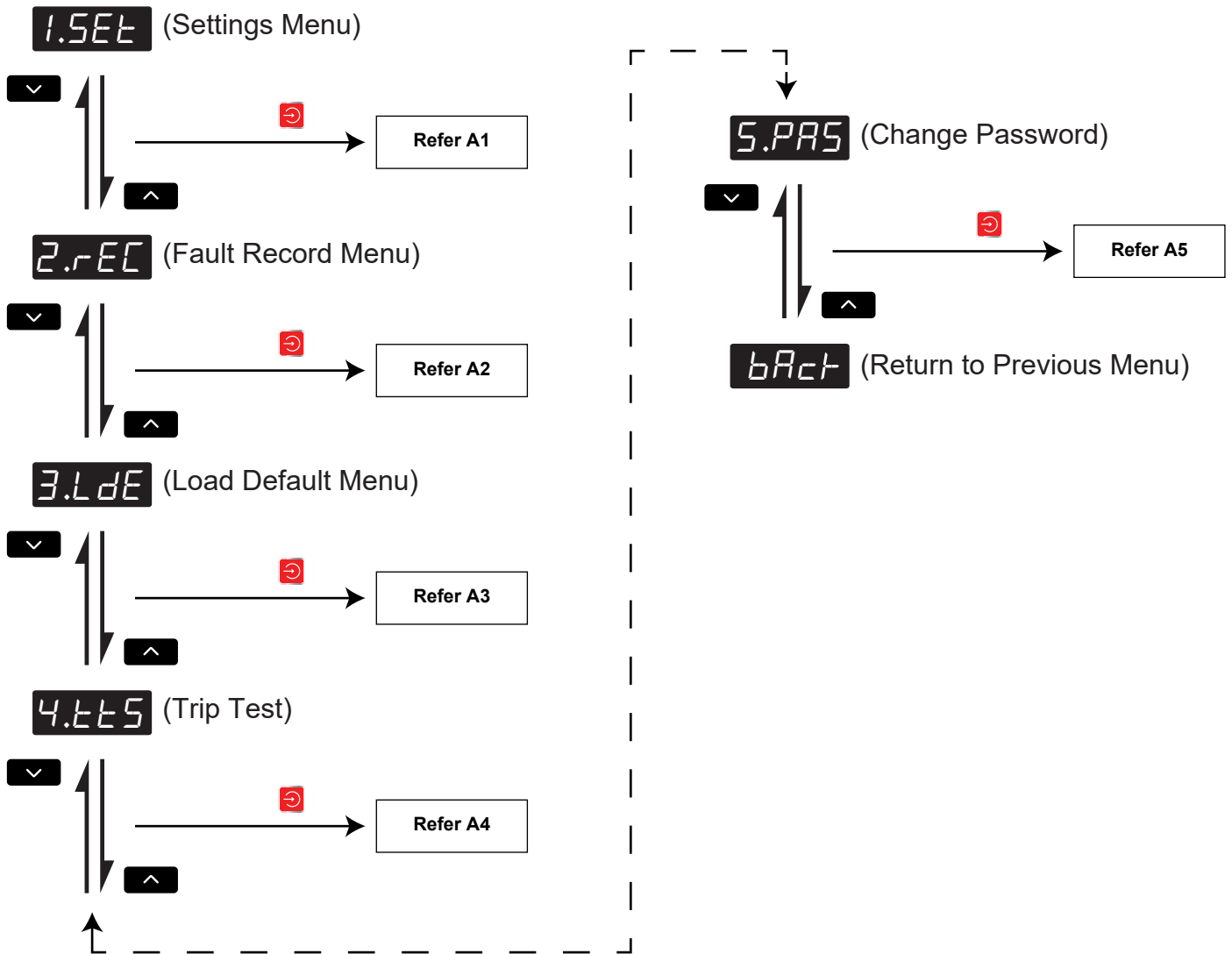

A1 (SETTINGS SUB MENU)

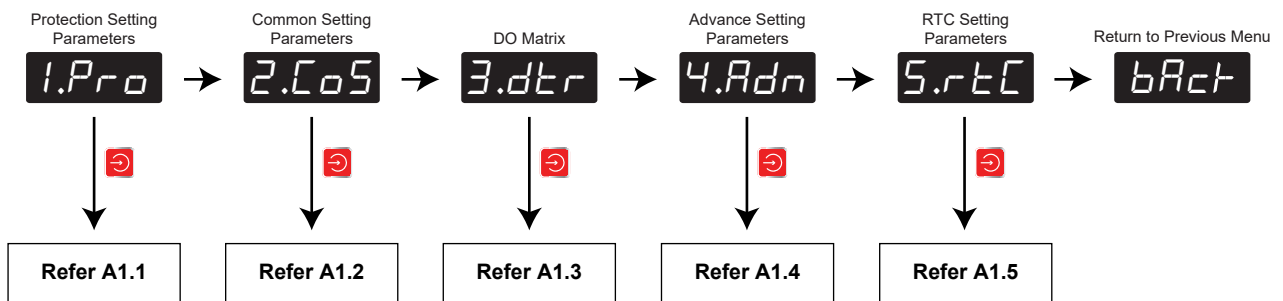

A1.1 (PROTECTION PARAMETER SUB MENU)



A1.2 (COMMON SETTING SUB MENU)

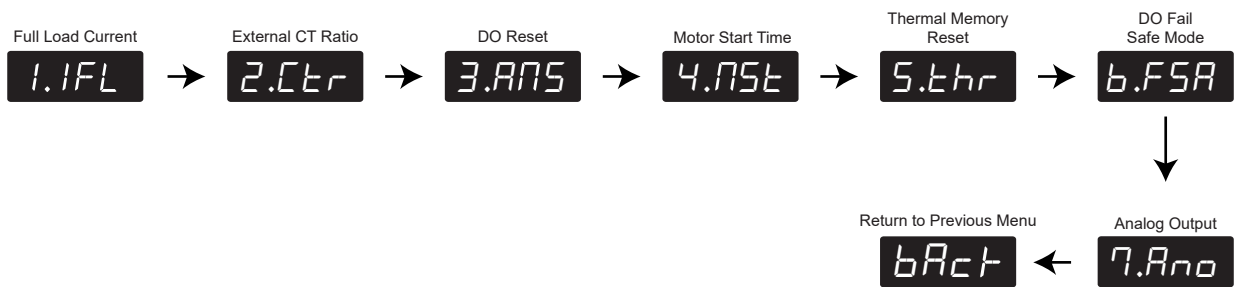

A1.3 (DIGITAL OUTPUT MATRIX SUB MENU)

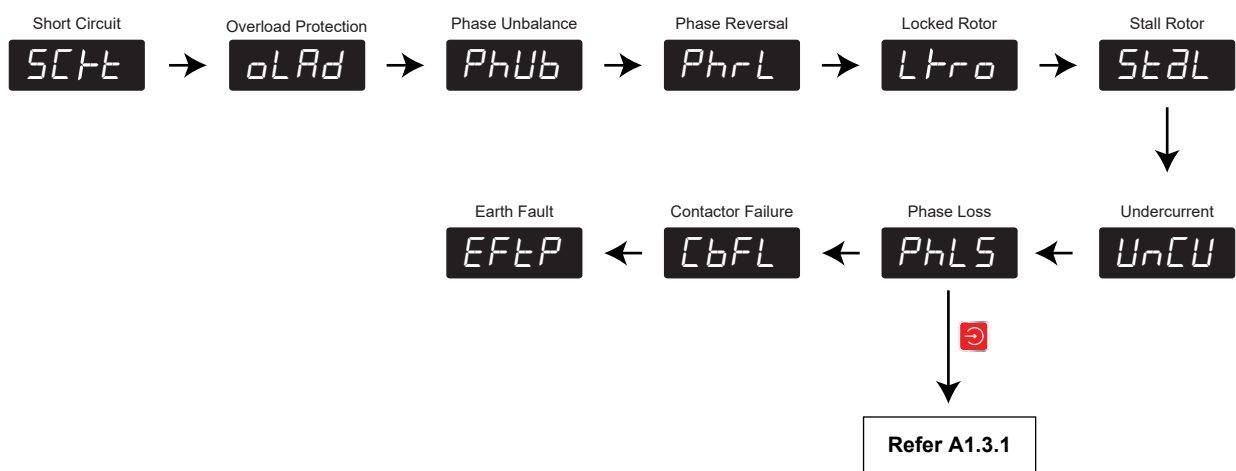

A1.4 (ADVANCE SUB MENU)



A1.5 (rtC SUB MENU)



A2 (RECORD MENU)

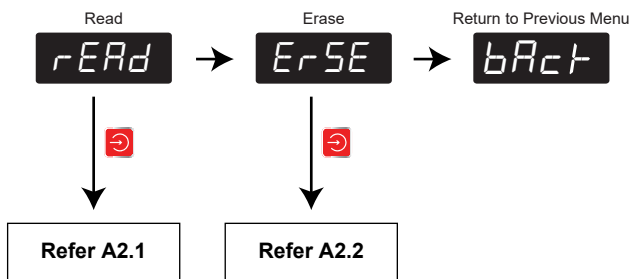

A2.1 (READ FAULT RECORD SUB MENU)

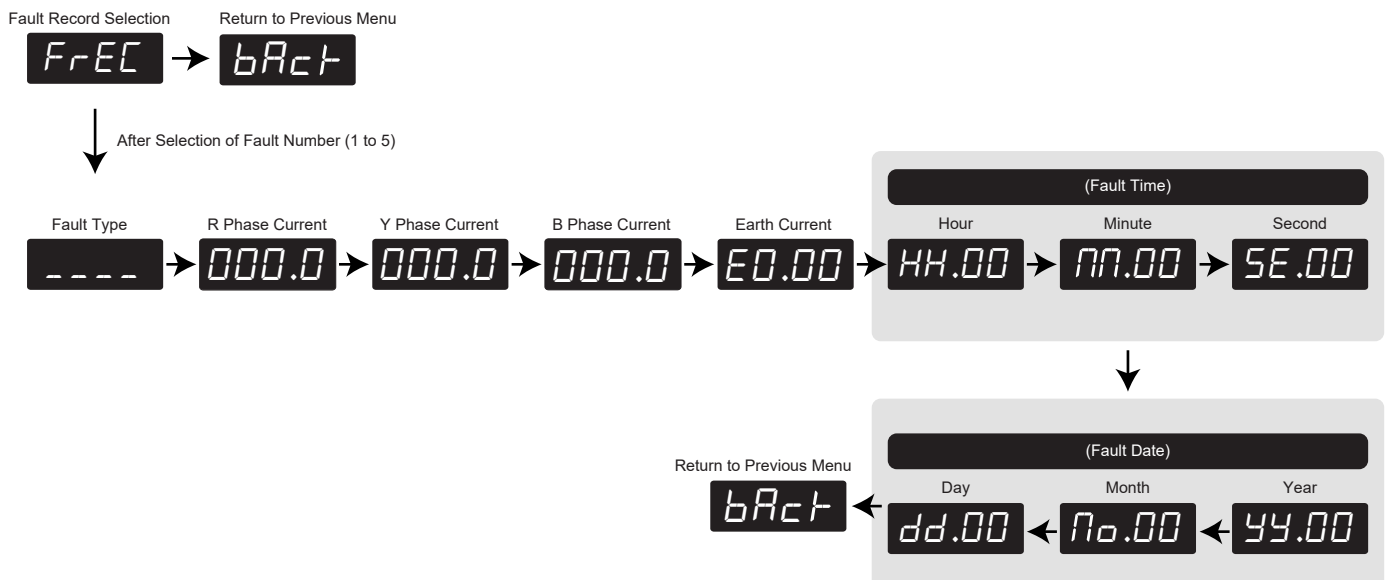

A2.2 (ERASE FAULT RECORD SUB MENU)

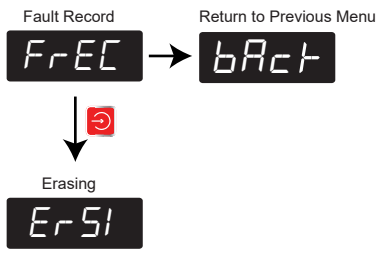

A3 (LOAD DEFAULT SUB MENU)



It will take the default value of Setting Parameters.

A4 (TRIP TEST MENU)

This test menu verifies all LED segments and digital outputs (DO).

During the trip test, all LEDs (both 7-segment LEDs and indication LEDs) will glow sequentially, one after another. After this, the system will prompt the user to press specific keys one at a time to verify that all keys are functioning correctly.

Next, the trip test shifts to the Base Module. Press the keys on the base module to operate its digital outputs (DOs). For each key state—pressed and released—Relay-1 and Relay-2 will be activated accordingly.

To operate Relay-3, apply the digital input (DI) and then press the Reset button on the base module.

A5 (CHANGE PASSWORD)



A1.3.1 CONFIGURATION OF DO MATRIX

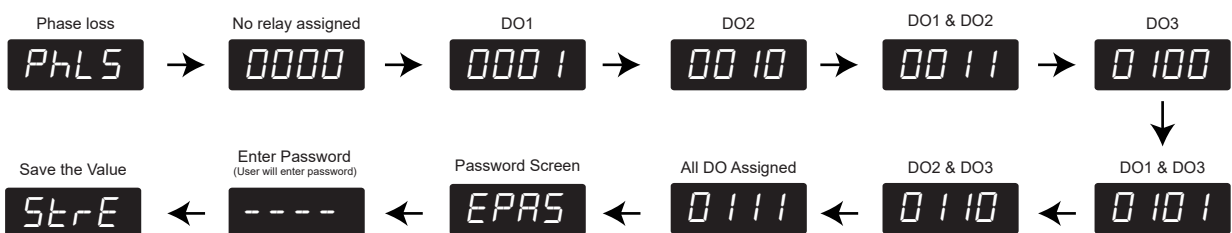

Annexure - A

4-Digit Short Name	Description	4-Digit Short Name	Description
<i>SCFL</i>	Short Circuit	<i>OLSC</i>	Over Load + Short Circuit
<i>OLPd</i>	Overload Protection	<i>OLSt</i>	Over Load + Stall Rotor
<i>LECF</i>	Leakage Protection	<i>CbSC</i>	Contacture Failure + Short Circuit
<i>UnbL</i>	Phase Unbalance	<i>CbOL</i>	Contacture Failure + Over Load Protection
<i>PhrL</i>	Phase Reversal	<i>CbLC</i>	Contacture Failure + Leakage Protection
<i>LTrO</i>	Locked Rotor	<i>CbUb</i>	Contacture Failure + Unbalance
<i>SC.Lr</i>	Short Circuit + Locked Rotor	<i>Cb.Pr</i>	Contacture Failure + Phase Reversal
<i>OL.Lr</i>	Over Load + Locked Rotor	<i>Cb.Lr</i>	Contacture Failure + Locked Rotor
<i>StRL</i>	Stall Rotor	<i>SC.Lr</i>	Short Circuit + Locked Rotor
<i>SC.St</i>	Short Circuit + Stall Rotor	<i>Cb.St</i>	Contacture Failure + Stall Rotor
<i>UnCU</i>	Under Current	<i>Cb.UC</i>	Contacture Failure + Under Current
<i>UC.PL</i>	Under Current + Phase Loss	<i>Cb.PL</i>	Contacture Failure + Phase Loss
<i>PhLS</i>	Phase Loss	<i>Strt</i>	Motor is in Start State
<i>CbFL</i>	Contacture Failure	<i>run</i>	Motor is in Run State
<i>MLFL</i>	Multiple Fault	<i>StoP</i>	Motor is in Stop State

Trouble Shooting Points

Problem	Cause of Problem	Remedy
Wrong Measurement / Display	Wrong connection	<ul style="list-style-type: none"> •Check the no. of wires passed through the CT opening •Check the CT selection in common setting menu
Wrong Measurement / Display	Relay is inTrip/pickup state Motor is running	<ul style="list-style-type: none"> •Relay will not allow to change any of its setting unless it is in healthy state and motor is stopped •There should not be any pickup & last fault should be acknowledged before editing any setting parameter. Short press RESET for acknowledge the last fault
Protection not getting pickup	Protection is blocked from protection setting menu	Check that the particular protection setting is activated or not.
Output contact not operating	Protection Pickup is Disabled (OFF) Annunciation DO is not assigned Aux Supply not in range	<ul style="list-style-type: none"> •Check that protection setting for pickup level •Check DO matrix assignment •Verify the output contact operation via "TRIP TEST" •Check aux supply range within specified band only

Sales Offices

Ahmedabad
401, Shipl Zeveri,
Beside Shyamal Iconic,
Above Westside,
Shyamal Cross Road,
Ahmedabad - 380015
E-mail.: ahmedabad@bchindia.com

Bangalore
2nd Floor, 130/5,
K.H. Road (Double road),
Bangalore - 560 027
Tel.: 080-41144879 / 22236759
E-mail: bangalore@bchindia.com

Bhubaneswar
Mallick Commercial
Complex Plot No.: A/69, unit - 3
Bhubaneswar - 751 001
Tel.: 0674-2380988
E-mail.: bhubaneswar@bchindia.com

Chandigarh (Panchkula)
SCO -270, 2nd Floor,
Sector-16, Panchkula
Haryana-134 113
Tel.: 0172-5078957 / 5049905
E-mail.: chandigarh@bchindia.com

Chennai
Flat No. 3A, 3rd Floor,
Sree Apartments,
No.508, TTK Road,
Alwarpet, Chennai 600 018
Tel.: 044-24337046, 24337047
E-mail: chennai@bchindia.com

Coimbatore
87, Dr. Nanjappa Road,
Coimbatore - 641 018
Tel.: 0422-2305311 / 2302599
E-mail: coimbatore@bchindia.com

Delhi 1
801, Akash Deep Building,
26A, Barakhamba Road,
New Delhi - 110 001
Tel.: 011-23313878 / 43518200
E-mail: delhi@bchindia.com

Delhi 2
710, Deepali Building, 92
Nehru Place, New Delhi - 110
019 Tel.: 011-45720334
E-mail: delhi2@bchindia.com

Dehradun
8, Co-operative Industrial Estate,
Patel Nagar, Dehradun-248001
E-mail: dehradun@bchindia.com

Faridabad
20/4, Mathura Road,
Faridabad - 121 006 (Haryana)
Tel/fax.: 0129-4293009
E-mail: faridabad@bchindia.com

Hyderabad
1-8-303/48/13/102, Arya One,
2nd Floor, P. G. Road,
Secunderabad - 500 003
Tel.: 040-66206263/27890306
Fax: 040-66207273
E-mail: hyderabad@bchindia.com

Indore
330-331, Indraprastha Tower,
3rd Floor, 6, M.G. Road,
Indore - 452 001
Tel.: 0731-2510011 / 2510012
E-mail: indore@bchindia.com

Jaipur
25, Hathroi, Gopalbari,
Jaipur - 302 001
Tel.: 0141-2363521
E-mail: jaipur@bchindia.com

Jamshedpur
A.J. Tower, 2B,
2nd Floor, R-Road, Bistupur,
Jamshedpur - 831 001
E-mail: jamshedpur@bchindia.com

Kolkata
Block 1E, 216,
Acharya Jagadish Chandra Bose
Road, Kolkata - 700 017
Tel.: 033-22871728 / 46021884
E-mail: kolkata@bchindia.com

Lucknow
Shop No. 3, First Floor,
Tower T-10, Millennium Place IBB - 2,
Sushant Golf City, Sultanpur Road,
Lucknow U.P. - 226030
Tel.: 0522-4025597/4025997
E-mail: lucknow@bchindia.com

Ludhiana
S.C.O. - 18, 2nd Floor,
Feroze Gandhi Market,
Ludhiana - 140 001
Tel.: 0161-5021807/5022808
E-mail: ludhiana@bchindia.com

Madurai
12, Parvathi Plaza-3rd Floor,
70 Feet Road, Ellis Nagar
Madurai-625016, Tamilnadu
Email: madurai@bchindia.com

Mumbai
A-151, Mittal Tower,
Nariman Point,
Mumbai - 400 021
Tel.: 022-22822947/22850162
Fax: 022-22822858
E-mail: mumbai@bchindia.com

Patna
No.703, 7th Floor, Luv Kush
Tower, Exhibition Road,
Patna - 800001

Pune
8, Sarosh Bhavan,
16-B/1, Dr. Ambedkar Road,
Pune - 411 001
Tel.: 020-41210002
E-mail: pune@bchindia.com

Raipur
6th Floor, Office No. 607,
Babylon Capital, Near Oswal
Petrol Pump, VIP Chowk,
G.E. Road, Raipur - 492 006
Tel.: 0771- 4045053
E-mail: raipur@bchindia.com

Vadodara
301, Third Floor, "Florence Classic",
10, Ashapuri Co-Op. Hsg. Soc. Ltd., Opp. VUDA
Housing, Near Cow Circle, Akota, Vadodara - 390 020
Tel.: 0265-2345068/2345069
Telefax: 0265-2345068,
E-mail: vadodara@bchindia.com



Customer Center Quick Response
Service, Excellent Technical Support

1800 103 9262



**BCH
ELECTRIC
LIMITED**

BCH Electric Ltd.

20/4, Mathura Road, Faridabad-121006, Haryana
Tel : 0129 4063000/4293000, Fax : 0129-2304016
E-mail: customercare@bchindia.com