



Installation Instruction BOCR 4.0 Motor Protection Relay

Thank you for purchasing the BCH BOCR 4.0 Relay

SAFETY PRECAUTIONS

Be sure to read the Installation Guide and safety precautions before using the product.

 **Warning :** Failure to comply with this message may result in damage to the device or system.

 **Caution :** Incorrect handling of the device may result in damage to the device or system.

Caution

- Change in setting is possible only in motor stop state and there should not be any fault with appropriate password. Default password is four times enter key (Ent. Ent. Ent. Ent.)
- Keep the product in the place where is no humidity and dust.
- Please check the phase & polarity while inserting the CT wire.
- Wrong polarity or phase can cause the wrong result (may cause Phase Reversal / Unbalance / Earth Fault).
- The product which is different from order may cause damage to the device or system.
- Installation, maintenance and inspection of the product should be performed by the qualified engineers.
- After every Trip acknowledge the relay with front RESET button.
- Wire the terminal after confirming the terminal number, it may cause the damage or fire.
- Recommended to use BCH supplied CBCT only.

Warning

- Do not change the setting during motor running.
- Turn off the upstream breaker before installing or service to prevent electric shocks & burn due to short circuit.

Overview

This Installation Instruction takes you through the installation and setup of BOCR 4.0 series motor protection relays and helps user to get setup and running as quickly as possible. This guide contains only basic information to operate the relay.

General Description

BOCR 4.0 series motor protection relay is a micro controller based relay designed for protection of LV & MV motors. It is equipped with 3 output relays for trip and alarm. Following are the brief

Technical Data

Parameter

Operational Current
Frequency Range
Protection

Accuracy

Trip Time
Trip Current (Phase)
Trip Current* (Earth)

Display

Auxiliary Supply (Refer Ordering Information)

Contact Rating

DO Contact

CBCT*

DO Reset

Mounting

Temperature Operation

Temperature Storage

Connection Type

For current

For Others (Aux sup, Relay contact etc.)

Description

For 60A model (0.5 - 8.0 x IFL) & For 5A model (0.05 - 10.0 X IFL)
50 / 60 Hz

Overload, Under Current, Short Circuit, Lock Rotor, Stall, Unbalance,
Phase Loss, Phase Reversal, Earth Fault*, CB Failure

$\pm 5\%$ (or ± 100 mSec) (which ever is higher)

$\pm 5\%$ (or ± 0.020 Amp) (which ever is higher)

$\pm 5\%$ (or ± 0.020 Amp) (which ever is higher)

LED Type

85V to 270V AC/DC

1 C/O Contact - N/O contact, 10A / 250V AC or 12V DC;
N/C contact, 10A / 250V AC or 12V DC

2 N/O Contact with 2 common, 7A / 250V AC or 12V DC

30 mA to 2 Amp : CT Ratio 1:1500

Automatic / Manual

35 mm Din-rail / Panel mount

0°C to 70°C

-10°C to 85°C

Penetration / Tunnel Type

Screwed Terminal

NOTE :

* Model dependant.

Ordering Information

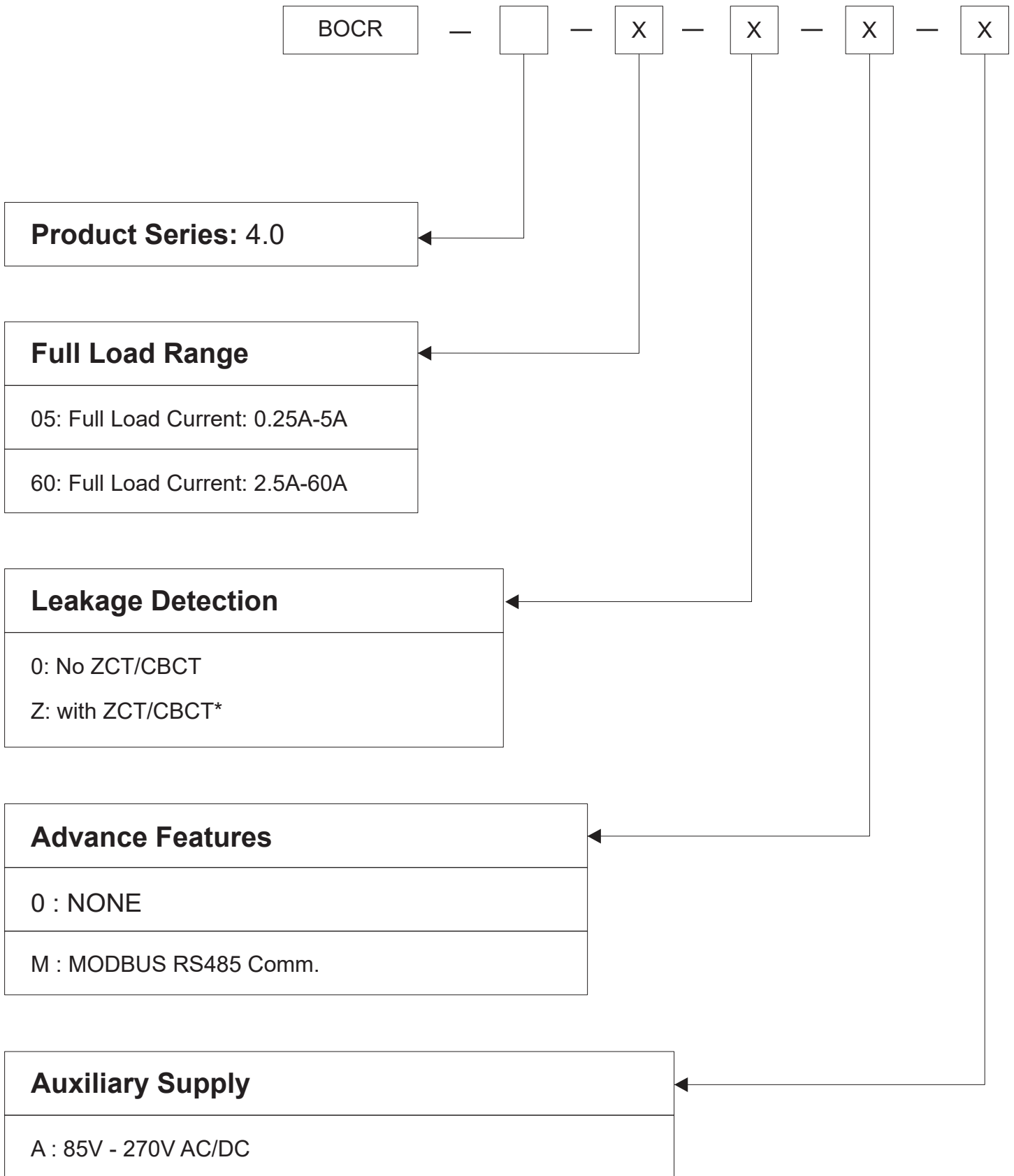

* CBCT will be offered only when CBCT model is selected (not for E model: Internal Residual calculations)

Human Machine Interface

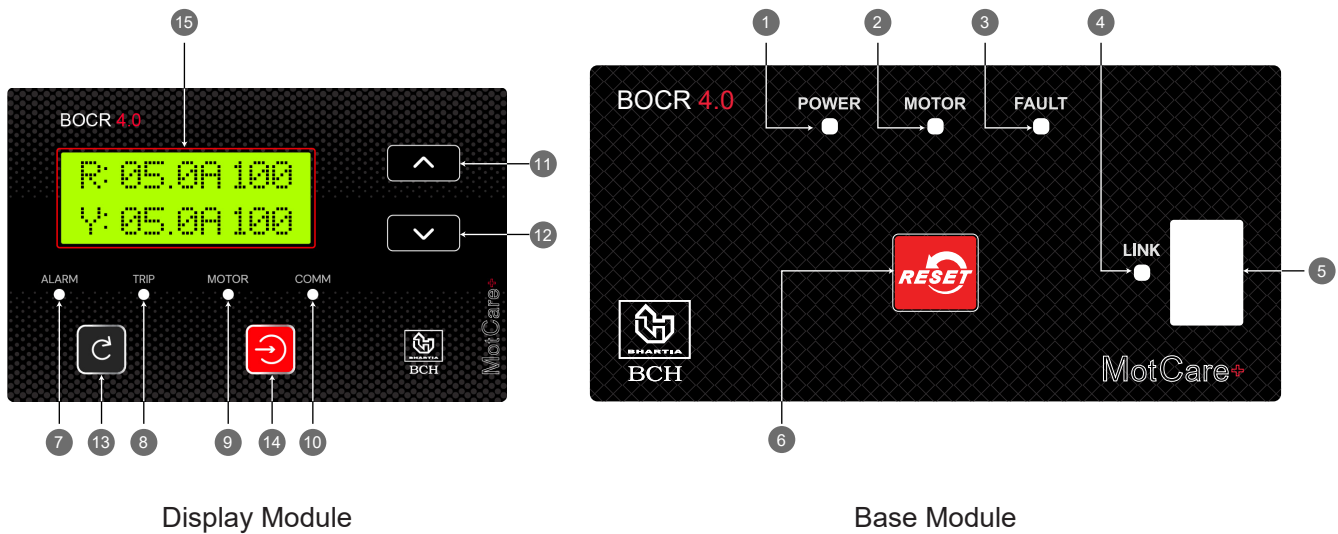

- 1 Power LED: When lit up indicates device is Powered Up.
- 2 Motor LED: When Blink indicates Motor is in Start Condition. When Motor is in RUN condition it stop blinking and become steady.
- 3 Fault LED: When motor detects any fault pickup it starts blinking. It glows steady when timer of the corresponding fault expires and the pickup converted into trip.
- 4 Link LED: When the BOCR4.0 is ready and the connection with Display Module established it starts blinking. So for Normal operation this LED must blink every half a second (approx).
- 5 Link Cable connection port to communicate with Base Module.
- 6 Reset Key: To acknowledge any fault from Base Module itself.
- 7 Alarm LED: this LED starts blinking if any Fault pickup detected.
- 8 Trip LED: If litted up, indicates the relay has been triped. It starts glowing continuously if any fault timer expires and resulted in trip condition. Upon acknowledge the fault (if the fault recovered) this will be reset.
- 9 Motor LED: Same as Motor LED in the Base Module.
- 10 Comm LED: Same as Link LED in the Display Module. For Normal Operation this LED should blink. In link Fail condition with Display module this LED remains steady state.
- 11 Up Key: Navigation key to scroll up the LCD Display.
- 12 Down Key: Navigation key to scroll down the LCD Display.
- 13 Exit Key: To exit from Current Menu
- 14 Enter Key: To enter Parameter setting and Log Record Menu
- 15 LCD Display: 12x2 Character LCD Display

Dimension Details

All the Dimensions are in mm (Gen Tol. : ± 1.0 mm)

Display Module

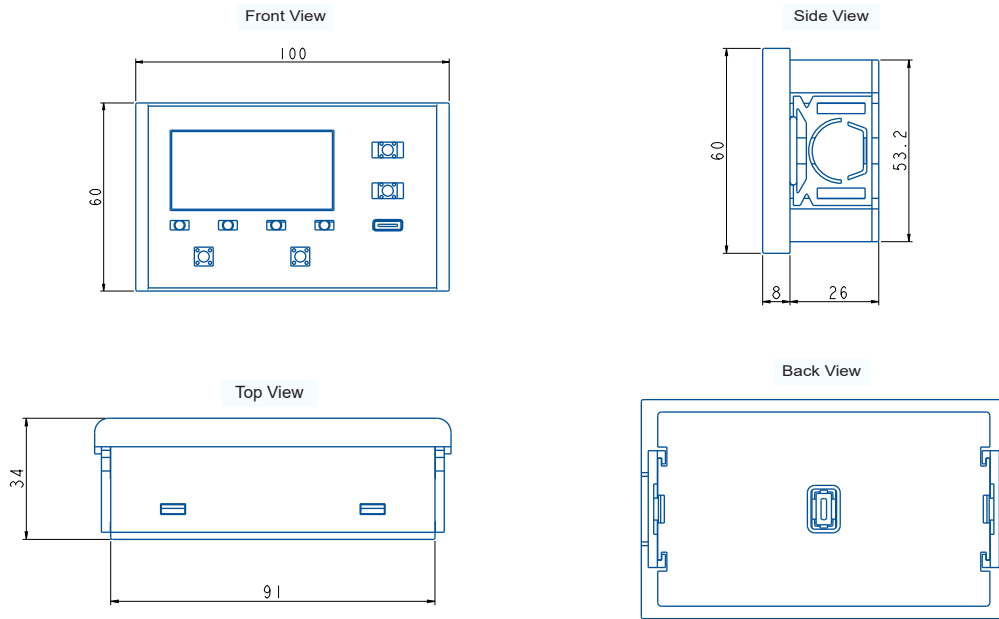

Base Module

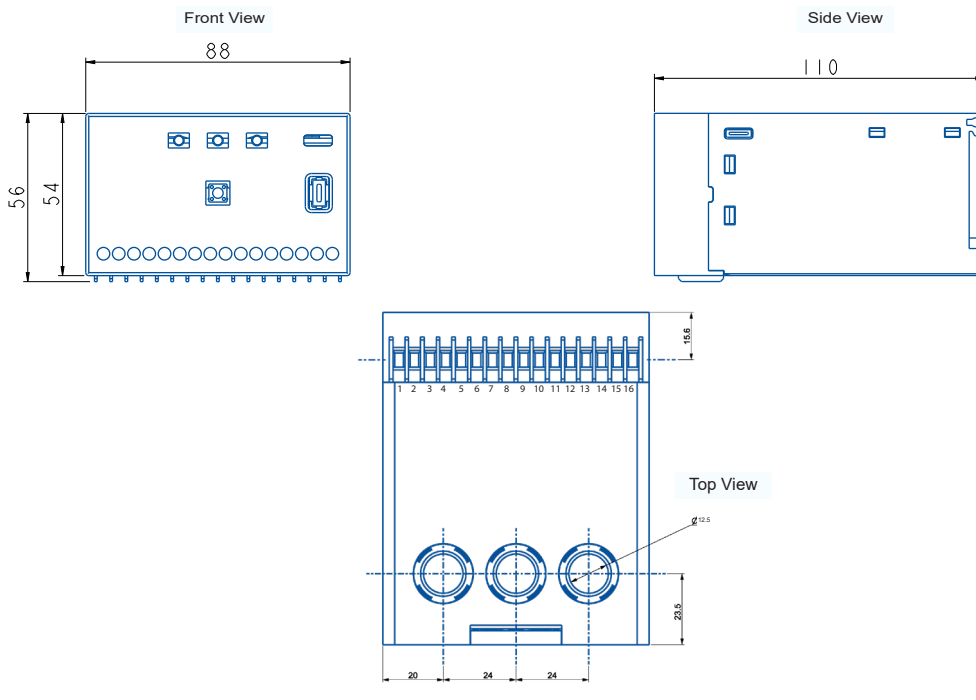

Base Module

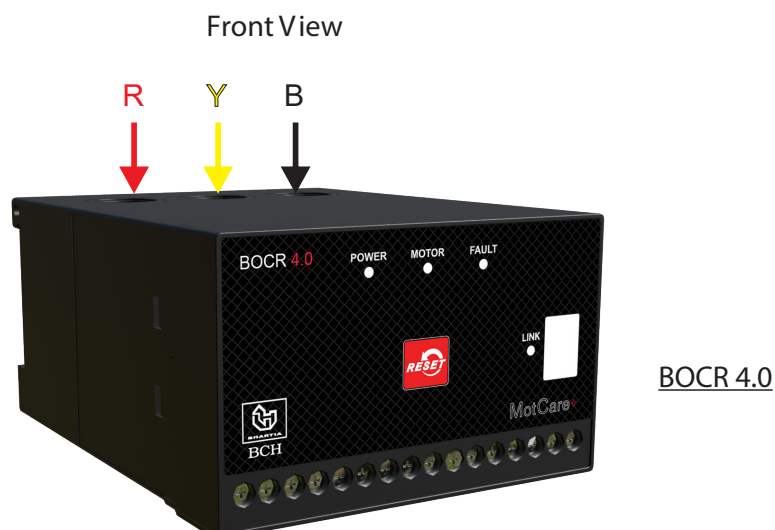

BOCR Terminal Function	
Terminal No.	Description
1	AUX-CONTROL INPUT -L
2	X
3	AUX-CONTROL INPUT -N
4	RLY1-COM
5	RLY1-NO
6	RLY1-NC
7	RLY2-COM
8	RLY2-NO
9	RLY3-COM
10	RLY3-NO
11	X
12	Ext-RS-485-A*
13	Ext-RS-485-B*
14	X
15	Ext-CBCT-H*
16	Ext-CBCT-L*

NOTE :

* Model dependant.

Electrical Installation

Refer the wiring diagram and terminal description for electrical connection. Motor's R, Y, B phase wires should be passed through the CT openings provided in the device.

BOCR 4.0 with external CBCT for Earth fault detection

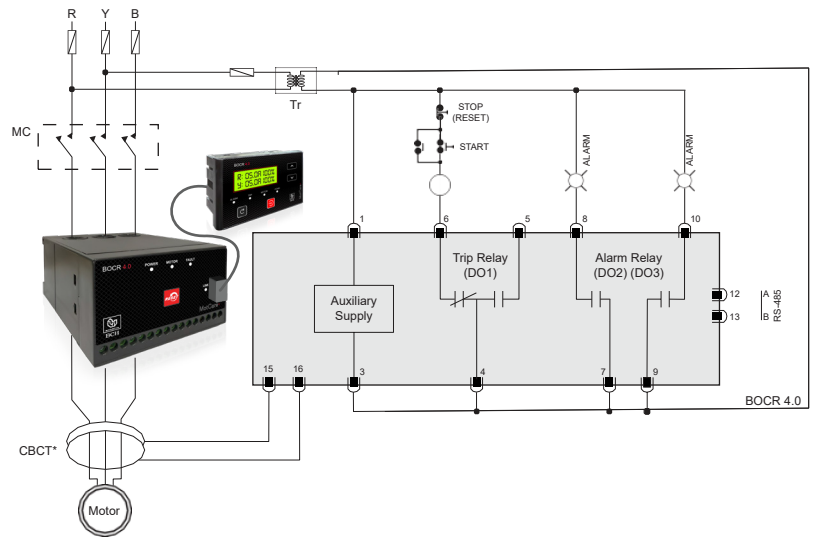

BOCR 4.0 with primary CT and external CBCT

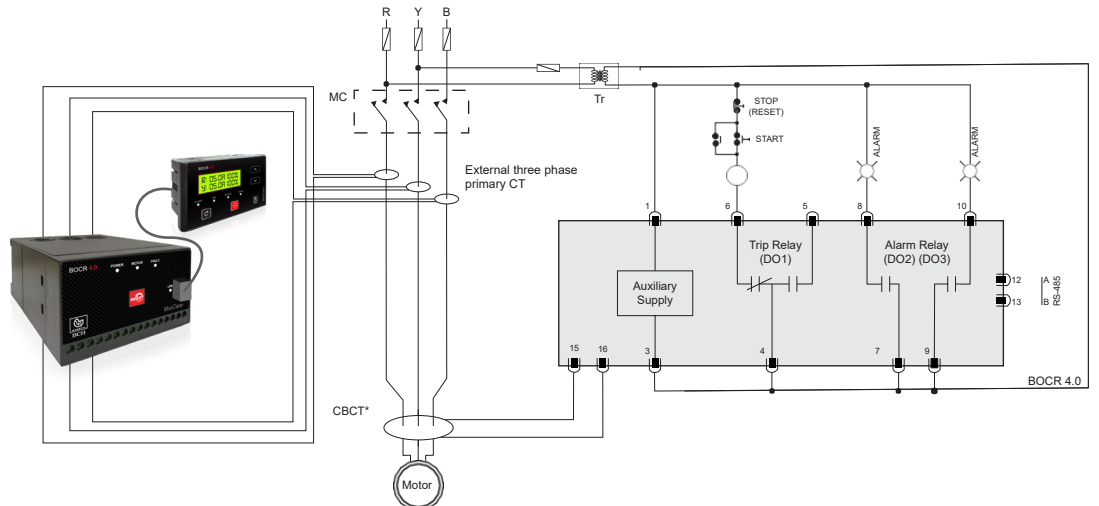

BOCR 4.0 with primary CT & without external CBCT

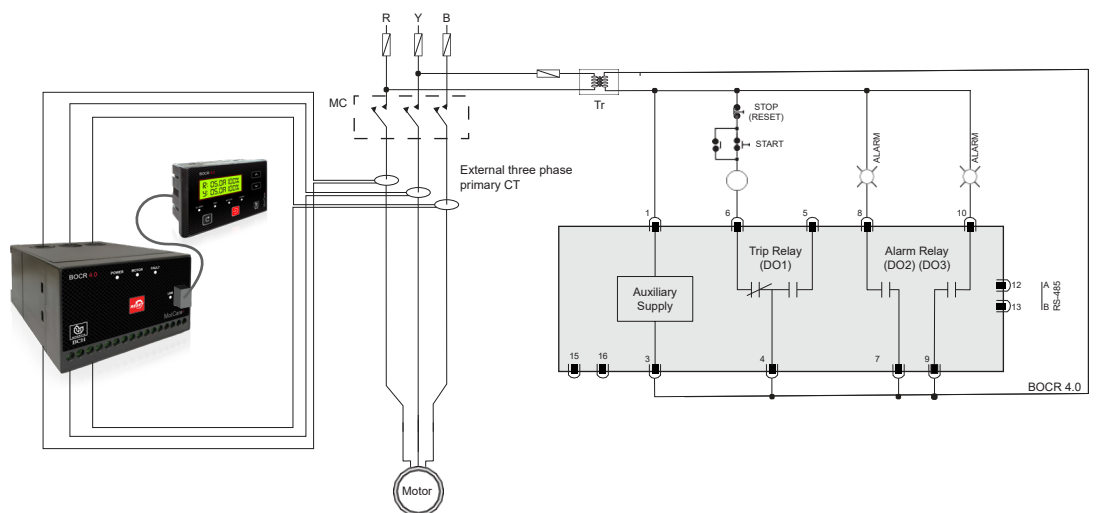

NOTE :

* Model dependant.

Protections Setting Parameter

Parameter	Setting Range		Step Size	Unit	Default Setting
	Min.	Max.			
Over-load Characteristic	DEFT	THERM	-	-	DEFT
Over-load Pickup Level	50%	150%	1%	% IFL (Amp)	110%
Over-load Definite Time ^(1,2)	0.1	30.0	0.1	Sec	10
Thermal Trip Class	5	30	5	-	10
Short Circuit Pickup	200%	800% ⁽¹⁾ /1000% ⁽²⁾	50%	% IFL (Amp)	OFF
Short Circuit Trip Time	0.05	1.0	0.01	Sec	0.08
Leakage Fault Pickup (CBCT) ⁽³⁾	0.03	2A	0.01	Amp	OFF
Leakage Fault Trip Time (CBCT) ⁽³⁾	0.05	10	0.01	Sec	1
Under-Load Pickup Level	20%	90%	5%	% IFL (Amp)	OFF
Under-Load Trip Time	1.0	30.0	0.1	Sec	3
Unbalance Current Pickup Level	5%	50%	2.5%	% IFL (Amp)	OFF
Unbalance Current Trip Time	1	30	1	Sec	3
Phase Reversal Trip	OFF	ON	-	-	OFF
Locked Rotor Pickup Level	200%	800% ⁽¹⁾ /1000% ⁽²⁾	50%	% IFL (Amp)	OFF
Locked Rotor Trip Time	0.1	5.0	0.1	Sec	1
Phase Loss Trip Time	0.5	5.0	0.1	Sec	OFF
Stall Rotor Pickup Level	150%	800%	5%	% IFL (Amp)	OFF
Stall Rotor Trip Time	0.5	10	1	Sec	3
Contacto Fail Detection Time	0.1	10	0.1	Sec	0.5

NOTE :

* Model dependant.

(1) 60A model.

(2) 5A model.

(3) CBCT model.

Setting Parameters (DO Matrix)

There are 3 programmable DOs available which can be assigned to different Motor Faults as per requirement.

Fault	DO1*	DO2*	DO3*
Short Circuit	●	○	●
Overload	○	●	●
Earth Fault	●	○	○
Unbalance	●	●	●
Phase Reversal	○	○	○
Lock Rotor	●	○	●
Stall	●	●	○
Under Current	●	○	○
Phase Loss	○	○	●
Trip CB Fail	●	●	○

Note:

- * DO configuration is must for any fault action, otherwise fault detection will be limited to display only.
- * DO1 is recommended to configure for fault tripping.
- * Default configuration of DO matrix is all three DOs for all the faults mentioned above.

Common Setting Parameter

Parameter	Setting Range		Step Size	Unit	Default Setting
	Min.	Max.			
Full Load Current*	2.5 ⁽¹⁾ /0.25 ⁽²⁾	60.00 ⁽¹⁾ / 5.00 ⁽²⁾	0.01	Amp	60/5
External CT Ratio*	1	999	1	-	1
Motor start time	1.0	200.0	1.0	Sec	8
Thermal Memory Reset (Enable: ON, Disable: OFF)	OFF	ON	-	-	OFF
DO-1 Fail Safe Mode (Enable: ON, Disable: OFF)	OFF	ON	-	-	ON
DO Reset (ATO: Auto, MAN: Manual)	AUTO	MAN	-	-	MAN

NOTE :

- (1) Model Dependent (60A): - See ordering information for model selection.
- (2) Model Dependent (5A): - See ordering information for model selection.
 - CT ratio parameter will come into picture only when external primary CT is required to be used.
 - If CT ratio configured other than 1, The full load current will automatically configured as 5A. Irrespective of earlier configuration.

Display & Navigation

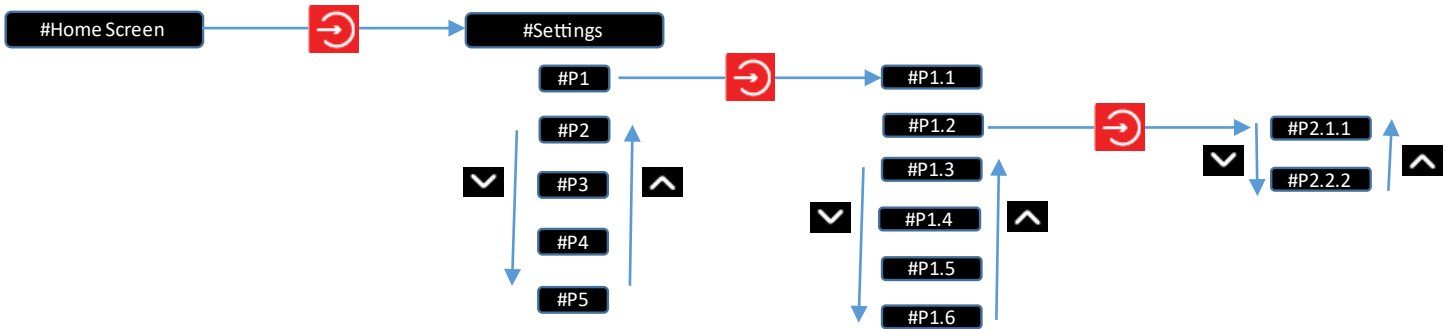

#Home Screen

R: 00.0 A 000%
 Y: 00.0 A 000%
 B: 00.0 A 000%
 E: 000 mA.
 # THERMAL #
 000%
 MOTOR: HEALTHY
 STOP STATE.

#Settings

< SETTINGS > #P1
 < RECORD > #P2
 < TRIP TEST >
 < RLY INFO > #P3
 < LOAD DEFALT > #P4
 < CNG PASSWD > #P5
 < FCTRY MENU >
 < F/W UPGRDE >
 ← BACK

#P1

SETTINGS #
 < PROTECTION > #P1.1
 < COMMON > #P1.2
 < DO MATRIX > #P1.3
 < COMMUNICATN > #P1.4
 < RTC > #P1.5
 < AUTO IFL SET > #P1.6
 ← BACK

#P1.1

#PROTECTION #
CHAR: THERML
I>: 110 % IFL
t>: 10.0 s
Tclass: 10
I>>: OFF
t>>: 0.08 s
IeCT>: 2.51 A
teCT>: 0.05 s
I<: OFF
t<: 03.0 s
I Ub: OFF
t Iub: 03 s
Ph Rev: OFF
ILR: OFF
t LKR: 10.0
t Ph Los: OFF
I STL: OFF
t Stall: 3.0 s
t CBFL: OFF
← BACK

#P1.2

COMMON #
IFL: 5.00 A
CT-RATIO: 001
tstart: 008 s
ThmReset: OFF
TpRyFLSf: OFF
DOReset: ATO
FltSectn: ATO
← BACK

#P1.5

#RTC SETTING#
HOUR: 19
MIN: 29
SEC: 32
DATE: 20
MONTH: 01
YEAR: 2026
← BACK

#P1.3

#DO MATRIX#
I>>: 123
I>: 123
IUnb: 123
PhRev: 123
LKR: 123
Stall: 123
I <: 123
PhLos: 123
CBFAIL: 123
Lekc: 123
← BACK

#P1.4

#COMUNICATN#
SlaveAdd: 001
Baudrt: 19200
Parity: None
Baudrt: 19200
StopBit: 1
← BACK

#P2

< VIEW > #P2.1
< ERASE > #P2.2
← BACK

#P2.1.1

<RUN HOURS>
<TRIP COUNT>
<FLT RECORD>
<START-STOP>
← BACK

#P2.2.2

<RUN HOURS>
<TRIP COUNT>
<FLT RECORD>
<START-STOP>
← BACK

#P3

BOCR4.0 — 5A.
FW - B : 1.02.01

#P4

<LOAD DEFAULT>

#P5

New PASSWORD
Enter PASSWD
New PASSWORD
RE-PASSWORD

Troubleshooting Points

Problem	Cause of Problem	Remedy
Wrong Measurement / Display	<ul style="list-style-type: none"> • Wrong connection. • Incorrect CT Ratio. • Link connection is broken (Link Fail) 	<ul style="list-style-type: none"> • Check the no. of wires passed through the CT opening. • Check the CT ratio in Common Setting Parameter.
Protection not getting pickup	<ul style="list-style-type: none"> • Protection is blocked from protection setting menu. 	<ul style="list-style-type: none"> • Check that the particular protection setting is activated or not. • Check the magnitude of current level measured by device.
Output contact not operating	<ul style="list-style-type: none"> • Protection Pickup is Disabled (OFF). • Annunciation DO is not assigned. 	<ul style="list-style-type: none"> • Check that protection setting for Pickup Level. • Check DO matrix assignment. • Verify the output contact operation via "TRIP TEST". • Check fail safe setting. In fail safe mode, contacts behaviour is different.
BOCR is not getting ON	<ul style="list-style-type: none"> • Voltage should not be within the range as given in general description (Refer page no. 2). 	<ul style="list-style-type: none"> • Check the Voltage at Terminal No 1 & 3.
Phase reversal trip	<ul style="list-style-type: none"> • Wrong sequence of phase has been passed through built in CT tunnel. 	<ul style="list-style-type: none"> • Check the correct sequence and polarity of phase that has been passed through built in CT tunnel (Refer page no. 7)
Earth Measurement not working*	<ul style="list-style-type: none"> • Loose connection. • CBCT Should not be connected to dedicated terminal. 	<ul style="list-style-type: none"> • Refer Terminal Details to connect CBCT.

NOTE

* Model dependant (Available for ZCT model).



*Customer Center Quick Response
Service, Excellent Technical Support*

1800 103 9262

**BCH Electric Ltd.**

20/4, Mathura Road, Faridabad-121006, Haryana
Tel : 0129 4063000/4293000, Fax : 0129-2304016
E-mail: customercare@bchindia.com