

DC MILL DUTY CONTACTORS



BCH
ELECTRIC
LIMITED

DC Mill Duty Contactors

900 Range (Rating 15A, 25A, 50A, 150A, 300A & 600A)

BCH DC type 900 Mill Duty Contactors have been designed keeping in view the arduous environment and duty conditions in the crane and steel industries as well as industrial control applications. The range covers ratings 15A, 25A, 50A, 150A, 300A and 600A all capable of switching AC or DC circuits and fitted with operating coils which are DC energised. Surge suppressors to limit voltage transients are fitted as standard. The range covers single pole normally open with or without inductive time lag control and single pole normally closed switching arrangements.

Efficient mechanical interlocks can be fitted between adjacent normally open contactors of same size, for reversing duty. Electrical interlock switches which provide normally open or normally closed circuits can also be fitted.

Arch chutes with quick absorption and dissipation of heat are available. All these features are either inherent in the basic contactor design or are available as extras.

Construction

The construction comprises a cast or forged frame and armature assembly, forming the iron circuit and mounted on an insulated steel channel.

The arc shield and magnetic blow-out structures are designed to quickly absorb and dissipate the heat caused by arcing. Besides increasing contact life, the moulded arc chute offers advantages of improved mechanical life & cooling characteristics, plus superior arc tracking resistance. The arc chutes are hinged to provide front accessibility to the fixed and moving contacts for inspection and replacement purposes in operation, the arc chute is held in its 'down' position by a leaf spring arrangement which resists the effect of violent shock or vibration as encountered on devices such as charging cranes.

Operating coils

The operating coils are DC energised and are insulated to Class B. Protection against high induced voltage within the coil is given by 600 volt metrosil unit which is fitted to each contactor across the coil terminals.

High performance contacts

The main contacts are forged from high grade cadmium copper which has been proved by extensive testing and services, to be a superior material in terms of performance and contact type. The contacts are easily renewable.



Arc chutes

The arc chutes are moulded from asbestos filled material for quick absorption and dissipation of the heat created by arcing. Contact can easily be inspected and maintained without removing the arc chute.

Mounting arrangements

The contactors can be mounted on the panel in three different ways. On sheet steel and insulated base.

Surface mounting, back connected

This method is ideally suitable for panel builders who mount the components on bases of Sindanyo, permali or similar insulating material. The contactor is mounted flush against the panel connections being made to stems passing through the panel to the component. If required, wiring may be completed before mounting the components.

Surface mounting, front connected

This is suitable for panel builders who use single contactor or who can provide sufficient panel space for the main connections to run around the components rather than between them and the panel base.

Elevated mounting, front connected

This arrangement is intended for use with sheet steel panels where a dead back feature is required and the connections are all front-of-board. It is particularly suitable for use in torsion-box girder or control house locations.

The contactors are mounted on stand-off insulators allowing the mains connections to run between the contactor and the panel base. This system allows the main connections to be fitted before the components are assembled on to the panel base.

It also gives complete front accessibility because all contactors are assembled from the front and are therefore removable from the front without disturbing the main wiring.

Inductive time limit control (I tl)

The time limit control is still a universal favourite in crane and mill application because of its simplicity and ruggedness. No timers, series relays or dashpots are required. I tl Contactors (accelerating contactors) have two coils--a closing coil and a hold-out coil which is designed to prevent instantaneous closing. The hold-out coil operates on an iron core having a very small airgap and a highly inductive circuit. When the voltage is removed from the hold-out coil and the coil is short circuited, the current continues to flow for a short period of time. This prevents the contactor from closing until the current falls to almost zero by which time it is overcome by the current flowing in the closing coil, thus allowing the contactor to close.

Electrical interlocks

Two electrically-isolated circuits are available in each interlock assembly. Two interlock assemblies can be fitted to each type of normally open contactor and one assembly can be fitted to each normally closed or time lag (accelerating) contactor. A variety of circuit combinations can be obtained and conversions can be easily accomplished without removing the interlock from the contactor.

Mechanical interlocks

These are available between two single pole normally open contactors of same rating and are doubly insulated to afford the maximum safety in steel mill requirements.

Double Pole DC Contactors

A double pole version of normally open contactor is available which is made by mechanically interlinking the armature of two single pole normally open contactors. This provision is possible only for 914, 915 & 916 type contactors.

Electrical and mechanical ratings

All values are based on the requirements of IEC 158-1 IS 2959 and VDE 0660, ambient temperature 60°C, altitude not exceeding 2000 m etc.

Mechanical endurance : 20 million operations
 Electrical endurance : 1 million operations
 Number of operations : 600 operations per hour
 Insulation voltage (Ui) : 600 V

Contact arrangements

	CONTACTOR TYPE		
	914-915-916 (150A-300A-600)	924-925-926 (150A-300A-600)	934-935-936 (150A-300A-600)
Main contacts	1 NO	1 NC	1 NO (accelerating)
Auxiliary contacts	1 NO + 1 NC, 2 NO or 2 NC 2 NO + 2 NC 4 NO or 4 NC	1 NO + 1 NC or 2 NO or 2 NC	1 NO + 1 NC or 2 NO or 2 NC

Main contact rating - DC

CONTACTOR			RATED THERMAL CURRENT I _{Th}	OPERATIONAL CURRENT I _e DC 5	MAKING AND BREAKING CURRENT	RATED VOLTAGE
N/O SP	I TL SP	N/C SP	A	A	A	V
912	-	-	50	50	200	600
914	934	924	150	150	920	600
915	935	925	300	300	1800	600
916	936	926	600	600	3120	600

Main contact rating - AC

N/O SP	I _{tl} SP	N/C SP	200/250V		380/600V		200/250V		380/600V		CONTINUOUS 8 HOURS OPERATIONAL & BREAK	MAKE	INTERMITTENT CRANE & MILL OPERATIONAL	MAKE & BREAK	TWO OPERATIONS PER HOUR MAXIMUM BREAK
			HP	KW	HP	KW	HP	KW	HP	KW	A	A	A	A	A
912			5	12	30	25	25	19	40	30	50	200	65	100	200
914	934	924	50	37	100	75	75	55	125	90	150	900	200	300	900
915	935	925	100	75	200	150	150	110	250	186	300	1800	400	600	1800
916	936	926	200	150	400	300	250	186	500	370	600	3600	800	1200	3600

Auxiliary contact rating

SUPPLY	VOLT	CURRENT RATING V	TYPE OF LOAD A
AC	110	6.00	-
AC	660	1.00	-
DC	100/120	3.50	Resistive
DC	200/230	1.10	Resistive
DC	600	0.35	Resistive
DC	110	2.00	Inductive
DC	600	0.23	Inductive

Insulation class of Coil : B
 Coil operating volt. range : +10% -15% of rated voltage

CONTACTOR TYPE	912	914-924-934	915-925-935	916-926-936
Blowout coil rating	15,25,50	150A	300A	600A
Optg. time (app. msec.)				
Energised to fully closed	90	110	130	200
De-energised fully open	70	70	70	95
*Minimum arcing clearance				
Upto 250 Volts	50mm	64mm	89mm	114mm
Upto 600 Volts	64mm	89mm	114mm	140mm

(* Minimum Arcing requirement from any point on outer periphery of arc chute to door or top of enclosure)

Time delay for accelerating contactor : 650 m secs. (3 secs approx capacitors)

Mounting Arrangement

TYPE OF MOUNTING	TYPE OF CONNECTION	CAT. CODE	
		ON SHEET STEEL	ON INSULATED BASE
Surface	Front	XS	XI
Surface	Rear	YS	YI
Elevated	Front	ZS	ZI

Voltage code 110 DC : A1
 220 DC : B1
 440 DC : C1
 (specify coil voltage in place of Voltage code for non-standard Voltage).

Example : A Single pole normally Open contactor with 110V coil suitable for surface mounting front connection on sheet steel is termed as : 914XS/A1

Important : Please specify if contactor is intended for use on AC.

Coil Consumption

CONTACTOR TYPE	WATTS
912	30
914,934	35
915,935,924	40
916,936,925	45

Note : The coil of 926 Contactor is used alongwith economy resistor and therefore the wattage consumption varies with voltage. The information can be furnished on request.

Accessories

Auxiliary contact block

CONFIGURATION	CODE
1 NO + 1NC	AC10E11
2 NO	AC10E20
2 NC	AC10E02
4 NO	AC10E40
4 NC	AC10E04
2 NO + 2 NC	AC10E22

Mechanical Interlock

MOUNTING TYPE OF MOUNTING	BASE	CONTACTOR TYPE		
		914 CAT. CODE	915 CAT. CODE	916 CAT. CODE
Elevated	insulated base	AC10M1	AC10M5	AC10M9
Surface	insulated base	AC10M2	AC10M6	AC10M10
Elevated	Sheet Steel	AC10M3	AC10M7	AC10M11
Surface	Sheet Steel	AC10M4	AC10M8	AC10M12

Note : When the NC contactor is in its de-energised state. the auxiliary contact block is in its actuated mode, consequently, care must be taken to ensure the contact arrangement is in line with the requirements.

Terminal capacity of main contacts

CONTACTOR TYPE	SUITABLE FOR	
	CABLE SOCKET	BUSBAR
	A	CU MM2 AI MM2
912		10 x 2.5 10 x 2.5
914,924,934	200	25 x 5 40 x 5
915,925,935	400	25 x 5 40 x 5
916,926,936	900	40 x 10 50 x 10

Terminal capacity of auxiliary contacts : 10 mm²

Weights (Kg.)

TYPE	Kg.	TYPE	Kg	TYPE	Kg	Type	Kg
912	3* / 4#	934	10.0	935	17.3	936	32.3
914	8.2	915	13.6	916	21.8		
924	9.1	925	17.3	926	32.3		

Catalogue Code

Prod. code	TYPE	50A	150A	300A	600A
	Normally open	912	914	915	916
	Normally close		924	925	926
	Normally open (accelerating type)		934	935	936

Dimensions (mm)

912-Single Pole Normally Open

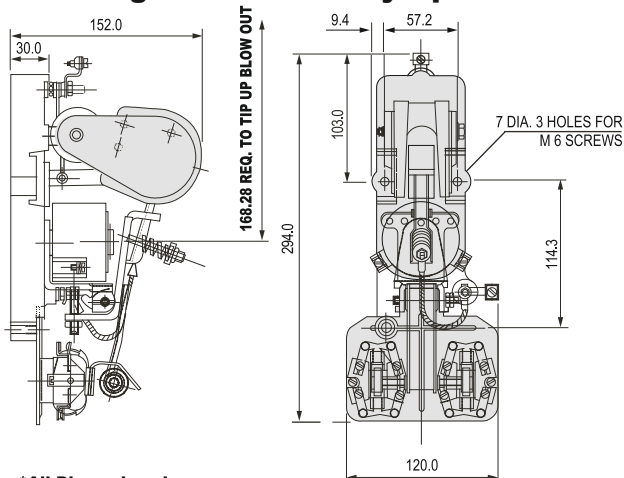

D912-Double Pole Normally Open

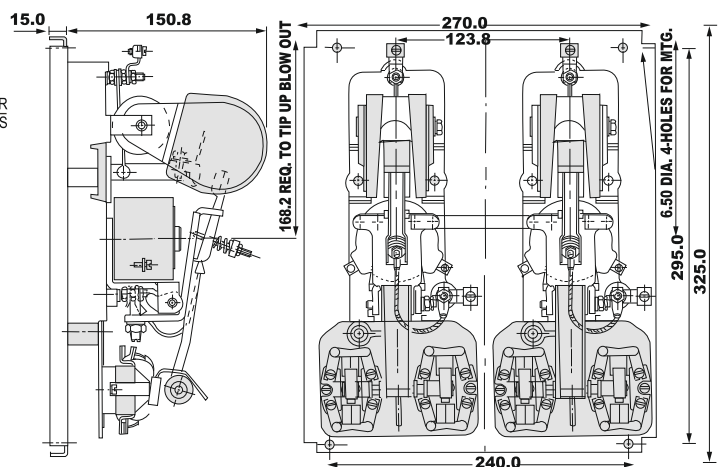

*All Dimensions in mm

Dimensions (mm)

914, 915, 916 - Single Pole Normally Open

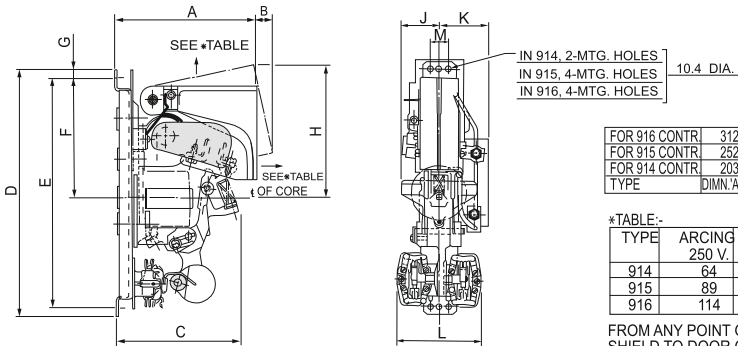

FOR 916 CONTR.	312	62	240	487	445	254	11	357	76	108	114	32	
FOR 915 CONTR.	252	64	203	429	406	225	11	298	65	77	114	32	
FOR 914 CONTR.	203	27	173	340	318	165	11	200	54	64	114	-	
TYPE	DIMN.'A'	DIMN.'B'	DIMN.'C'	DIMN.'D'	DIMN.'E'	DIMN.'F'	DIMN.'G'	DIMN.'H'	DIMN.'J'	DIMN.'K'	DIMN.'L'	DIMN.'M'	CHG.

*TABLE:-

TYPE	ARCING 250 V.	CLEARANCE AT 600 V.
914	64	89
915	89	114
916	114	140

FROM ANY POINT ON OUTER PERIPHERY OF BLOW OUT ARC SHIELD TO DOOR OR TOP OF ENCLOSURE.

934, 935 & 936 - Single Pole Normally Open With Hold Out Coil

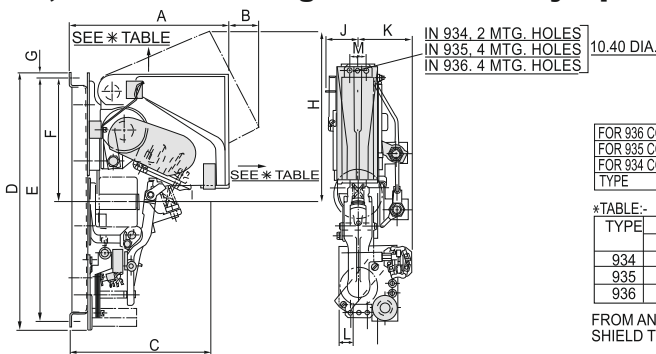

FOR 936 CONTR.	314	62	241	527	495	254	11	357	63	105	51	32	
FOR 935 CONTR.	252	64	203	484	467	225	11	298	56	86	51	32	
FOR 934 CONTR.	203	27	173	416	384	165	11	200	50	86	-51	-	
TYPE	DIMN.'A'	DIMN.'B'	DIMN.'C'	DIMN.'D'	DIMN.'E'	DIMN.'F'	DIMN.'G'	DIMN.'H'	DIMN.'J'	DIMN.'K'	DIMN.'L'	DIMN.'M'	CHG.

*TABLE:-

TYPE	ARCING 250 V.	CLEARANCE AT 600 V.
934	64	89
935	89	114
936	114	140

FROM ANY POINT ON OUTER PERIPHERY OF BLOW OUT ARC SHIELD TO DOOR OR TOP OF ENCLOSURE.

*All Dimensions in mm

926-Single Pole Normally Closed

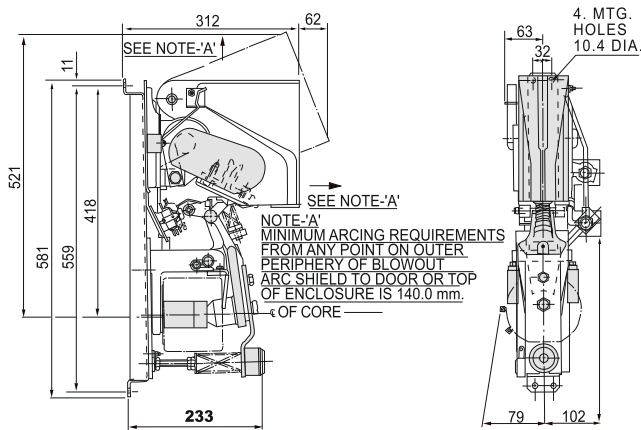

924 & 925-Single Pole Normally Closed

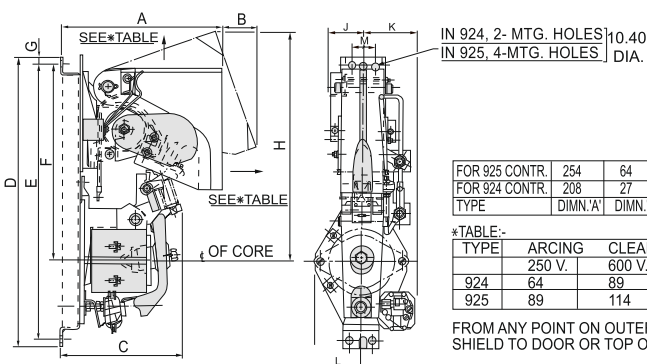

FOR 925 CONTR.	254	64	203	479	457	327	11	400	8	71	32		
FOR 924 CONTR.	208	27	165	403	381	259	11	284	50.0	81	-		
TYPE	DIMN.'A'	DIMN.'B'	DIMN.'C'	DIMN.'D'	DIMN.'E'	DIMN.'F'	DIMN.'G'	DIMN.'H'	ØDIMN.'J'	DIMN.'K'	DIMN.'L'	DIMN.'M'	CHG.

*TABLE:-

TYPE	ARCING 250 V.	CLEARANCE AT 600 V.
924	64	89
925	89	114

FROM ANY POINT ON OUTER PERIPHERY OF BLOWOUT ARC SHIELD TO DOOR OR TOP OF ENCLOSURE.

*All Dimensions in mm

Dimensions (mm)

D914-Double Pole Normally Open

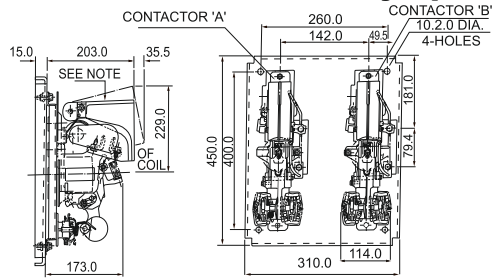

Supply Volts	Coil Volts Of Contactor 'A'	Coil Volts Of Contactor 'B'	Remarks
220 Vts D.C.	110 Volts D.C.	110 Volts D.C.	Coil of Contr. A & Connected in Series
440 Vts D.C.	220 Volts D.C.	220 Volts D.C.	Do
10 Volts D.C.	55 Volts D.C.	55 Volts D.C.	Do

NOTE:
MINIMUM ARCING REQUIREMENTS FROM ANY POINT ON OUTER PERIPHERY OF BLOWOUT ARC SHIELD TO DOOR OR TOP OF ENCLOSURE IS 90 mm AT 600 V D.C. MAX. 63 mm AT 250 V D.C. MAX.

D915-Double Pole Normally Open

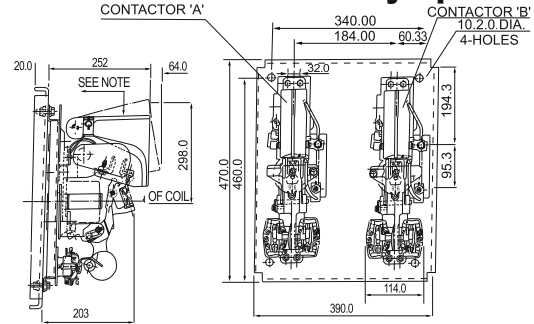

Supply Volts	Coil Volts Of Contactor 'A'	Coil Volts Of Contactor 'B'	Remarks
220 Vts D.C.	110 Volts D.C.	110 Volts D.C.	Coil of Contr. A & Connected in Series
440 Vts D.C.	220 Volts D.C.	220 Volts D.C.	Do
10 Volts D.C.	55 Volts D.C.	55 Volts D.C.	Do

NOTE:
MINIMUM ARCING REQUIREMENTS FROM ANY POINT ON OUTER PERIPHERY OF BLOWOUT ARC SHIELD TO DOOR OR TOP OF ENCLOSURE IS 114.30 mm AT 600 VOLTS D.C. MAX. 88-90 mm AT 250 VOLT D.C. MAX.

D916-Double Pole Normally Open

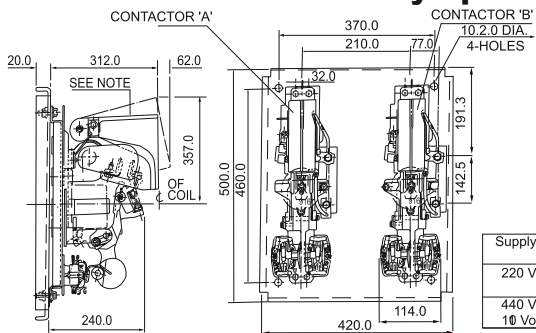

Supply Volts	Coil Volts Of Contactor 'A'	Coil Volts Of Contactor 'B'	Remarks
220 Vts D.C.	110 Volts D.C.	110 Volts D.C.	Coil of Contr. A & Connected in Series
440 Vts D.C.	220 Volts D.C.	220 Volts D.C.	Do
10 Volts D.C.	55 Volts D.C.	55 Volts D.C.	Do

NOTE:
MINIMUM ARCING REQUIREMENTS FROM ANY POINT ON OUTER PERIPHERY OF BLOWOUT ARC SHIELD TO DOOR OR TOP OF ENCLOSURE IS 139.7 mm

BCH ELECTRIC LIMITED

Visit us at : www.bchindia.com

Registered & Corporate Office : 1105, New Delhi House, 27, Barakhamba Road, New Delhi-110 001 Tel. : 91-11- 43673100

CIN : U31103DL1965PLC425953, Customercare No. 1800-103-9262, E-mail : marketing@bchindia.com

Works 1 : 20/4, Mathura Road, Faridabad-121 006 (Haryana) Tel. : 0129-4063000/4293000 Fax : 0129-2304016

Works 2 : 64-68, Sector-7, IIE, Pant Nagar, Rudrapur, Udham Singh Nagar - 263 153 (Uttarakhand) Tel. : 05944-250214/16 Fax : 05944-250215

Sales Offices :

Ahmedabad

401, Shilp Zeveri,
Beside Shyamal Iconic,
Above Westside,
Shyamal Cross Road,
Ahmedabad - 380015
Tel. : 079-46047740
E-mail : ahmedabad@bchindia.com

Bangalore

2nd Floor, 130/5,
K.H. Road (Double road),
Bangalore - 560 027
Tel. : 080-41144879 / 22236759
E-mail : bangalore@bchindia.com

Bhubaneswar

Mallick Commercial
Complex Plot No.: A/69, unit - 3
Bhubaneswar - 751 001
Tel. : 0674-3594970
E-mail : bhubaneswar@bchindia.com

Chandigarh (Panchkula)

SCO -270, 2nd Floor,
Sector-16, Panchkula
Haryana-134 113
Tel. : 0172-5078957 / 5049905
E-mail : chandigarh@bchindia.com

Chennai

Fat No. 3A, 3rd Floor,
Sree Apartments,
No.508, TTK Road,
Alwarpet, Chennai 600 018
Tel. : 044-24337046, 24337047
E-mail : chennai@bchindia.com

Coimbatore

87, Dr. Nanjappa Road,
Coimbatore - 641 018
Tel. : 0422-2305311 / 2302599
E-mail : coimbatore@bchindia.com

Delhi 1

801, Akash Deep Building,
26A, Barakhamba Road,
New Delhi - 110 001
Tel. : 011-23313878
E-mail : delhi@bchindia.com

Delhi 2

710, Deepali Building, 92
Nehru Place, New Delhi - 110 019
Tel. : 011-45720334
E-mail : delhi2@bchindia.com

Dehradun

8, Co-operative Industrial Estate,
Patel Nagar, Dehradun-248001
E-mail : dehradun@bchindia.com

Faridabad

20/4, Mathura Road,
Faridabad - 121 006 (Haryana)
Telfax : 0129-4293009
E-mail : faridabad@bchindia.com

Hyderabad

1-8-303/48/13/102, Anya One,
2nd Floor, P. G. Road,
Secunderabad - 500 003
Tel. : 040-66206263/
Fax : 040-66207273
E-mail : hyderabad@bchindia.com

Indore

330-331, Indraprastha Tower,
3rd Floor, 6, M.G. Road,
Indore - 452 001
Tel. : 0731-2510011 / 2510012
E-mail : indore@bchindia.com

Jaipur

25, Hathroi, Gopalbari,
Jaipur - 302 001
Tel. : 0141-2363521
E-mail : jaipur@bchindia.com

Jamshedpur

A.J. Tower, 2B,
2nd Floor, R-Road, Bistupur,
Jamshedpur - 831 001
Tel. : 0657-2321097
E-mail : jamshedpur@bchindia.com

Kolkata

Block 1E, 216,
Acharya Jagadish Chandra Bose Road,
Kolkata - 700 017
Tel. : 033-22871728 / 46021884
E-mail : kolkata@bchindia.com

Lucknow

Shop No.3, 1st Floor,
Tower T-10, Millenium Place,
IBB-2, Sushant Golf city,
Sultanpur Road,
Lucknow - 226 030
E-mail : lucknow@bchindia.com

Ludhiana

Block 1E - 18, 2nd Floor,
Feroze Gandhi Market,
Ludhiana - 140 001
Tel. : 0161-5021807/5022808
E-mail : ludhiana@bchindia.com

Madurai

12, Parvathi Plaza-3rd Floor
70 Feet Road, Ellis Nagar
Madurai - 625016, Tamilnadu
Tel. : 0452-4564830

Mumbai

A-151, Mittal Tower,
Nariman Point,
Mumbai - 400 021
Tel. : 022-22850162
E-mail : mumbai@bchindia.com

Pune

A- 605, 6th Floor,
Kumar Surabhi Building,
Pune Satara Road, Opp. Sai
Baba Temple, Pune - 411 009
E-mail : pune@bchindia.com

Raipur

6th Floor, Office No. 607,
Babylon Capital, Near Oswal
Petrol Pump, VIP Chowk,
G.E. Road, Raipur - 492 006
Tel. : 0771- 4020213
E-mail : raipur@bchindia.com

Vadodara

301, Third Floor, "Florence Classic",
10, Ashapuri Co-Op. Hsg. Soc. Ltd., Opp. VUDA Housing,
Near Cow Circle, Akota, Vadodara - 390 020
Tel. : 0265-2345068
Telefax : 0265-2345068,
E-mail : vadodara@bchindia.com

Other Branch Locations

Cochin : cochin@bchindia.com, Guwahati : guwahati@bchindia.com, Vishakapatnam : vizag@bchindia.com, Surat : surat@bchindia.com, Trichy : Trichy@bchindia.com

Resident Engineer Locations

Anantapur	Jodhpur	Madurai	Rajkot	Siliguri
Aurangabad	Jalandhar	Muzaffarnagar	Rajahmundry	Tirunelveli
Bhopal	Kanpur	Nagpur	Ranchi	Udaipur
Calicut	Katni	Nashik	Rourkela	Vapi
Gurgaon	Kharagpur	Nanded	Rudrapur	Vijayawada
Hosapate	Kota	Patna	Salem	Warangal
Hubli	Kolhapur	Puducherry	Satna	Yamuna Nagar