

ULTRA POWER

Air Circuit Breakers



User Manual

Maintenance Instructions of Ultra Power ACB



BCH

BCH
ELECTRIC
LIMITED

www.bchindia.com

CAUTION

- Non-observance of the safety instructions can result in severe personal injury or equipment damage.
- Successful and Safe operation of the equipment (including accessories) depends on proper handling, installation, operation and maintenance.
- Before commencing with installation or maintenance,
 - Disconnect power supply of the device
 - Ensure that device cannot be accidentally restarted
 - Verify isolation from supply and earthing
 - Cover and enclose all neighboring live equipment
 - Discharge spring
 - Follow engineering instructions of the device concerned
 - Before touching device, ensure you are free of electrostatic charge
- Ensure that deviations of the mains and control voltages do not exceed the specified operating limits, as this may cause malfunction, dangerous operation and damage to product.

1. On receiving
 - 1.1 Visual inspection
 - 1.2 Unpacking
 - 1.3 Handling
 - 1.4 Storage
 2. Understanding
 - 2.1 Identification
 - 2.2 Exploring
 - 2.3 Racking-out
 - 2.4 Operating
 - 2.5 Technical Data
 3. Installing
 - 3.1 Mounting & Door cut-out
 - 3.2 Termination
 - 3.3 Loading in panel
 - 3.4 Control circuit connections
 4. Accessories: Features & Mounting
 - 4.1 Cradle Mounted Accessories
 - 4.2 Breaker Mounted Accessories
 5. Protection & Control Units
 - 5.1 Identification
 - 5.2 Protection Characteristics
 6. Putting
 - 6.1 Reloading in Panel
 - 6.2 Checking ON-OFF operation
 - 6.3 Testing
 - 6.4 Setting P&C unit
 - 6.5 Trip simulation of P&C unit
 - 6.6 System in Connected Position
 - 6.7 Securing
 7. Maintenance & Operations
 - 7.1 Maintenance schedule & operations
 - 7.2 Accessories and Spares
 8. Useful hints
-

Section 1

On Receiving

- 1.1 Visual Inspection
- 1.2 Unpacking
- 1.3 Handling
- 1.4 Storage

1.1 Visual Inspection

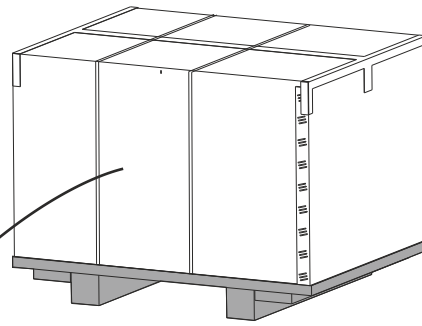

AIR CIRCUIT BREAKER
 Version : Fr1 3P EDO
 Rating : 1600A
 Cat. No. :
 Serial No. :

Before Unpacking,

- A) Inspect the carton for any damage. In case of visible damage to the carton, contact nearest branch office before unpacking.
- B) Verify the breaker version and rating written on the carton with your order.

Weights:

Before proceeding with unpacking, it is important to know the gross weight of the breaker for proper selection of handling equipment.

Approx. Gross Weight of breaker with packing , adaptors & accessories (kg)

Rating Specification Parameters																																		
Frame			I								II				III																			
Version			N	S	H	N	S	H	S	H	N/S	H	N	S	H	S	H	H	V	H	V													
Rated Uninterrupted current at 50deg.C In (A)			400-1600				2000				2500				400-2500				3200				4000				400-5000				6300#			
Weight kg	Fixed ACB	3P	60	62	69	64	64	69	69	69	76	83	83	83	83	83	83	130	130	138	138													
		4P (100%N)	73	76	85	79	79	85	85	85	120	132	132	132	132	132	132	143	143	170	170													
	Drawout ACB	3P	87	91	103	94	98	103	103	103	113	125	125	125	125	136	136	198	198	227	227													
		4P (100%N)	104	109	127	112	115	127	127	127	168	181	181	181	181	195	195	248	248	285	285													

50% N

Rating Specification Parameters				
Frame			III	
Version			H	V
Rated Uninterrupted current at 50deg.C In (A)			400 - 5000	
Weight kg	Fixed	4P (50% N)	137	137
	D/O	4P (50% N)	223	223

200% N

Rating Specification Parameters																
Frame			I				II				III					
Version			N	S	N	S	H	N	S	H	S	H				
Rated Uninterrupted current at 50deg.C In (A)			400 -1250				1600				2000				2000 - 2500	
Weight kg	Fixed	4P (200% N)	85	85	132	132	132	132	132	132	123	123				
	D/O	4P (200% N)	127	127	181	181	181	195	195	195	185	185				

40 deg C

Note: All weights are with Vertical configuration of Cradle adaptors

1.2 Unpacking



a) For Fixed Breakers:

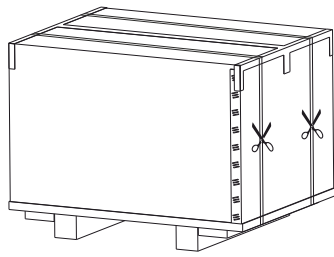

Step 1: Cut & remove the straps

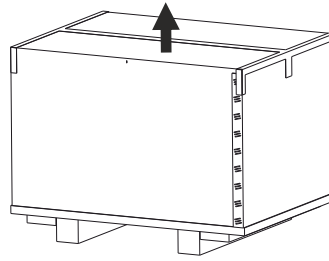

Step 2: Lift the carton and remove any accessories taped to the breaker or kept loose on the palette.

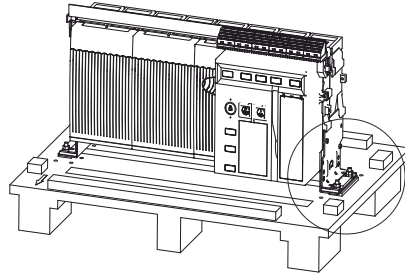

Step 3: Remove Breaker mounting nuts (8 Nos.) as indicated by arrows from both left and right sides

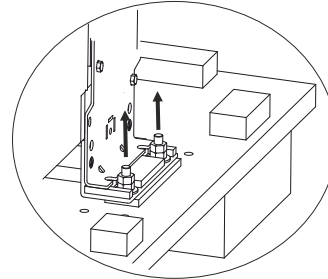

b) For Draw-out Breakers:

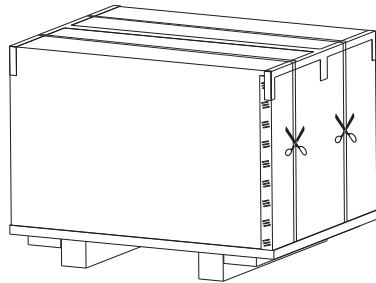

Step 1: Cut & remove the straps

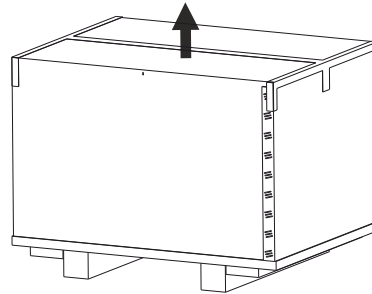

Step 2: Lift the carton and remove any accessories taped to the breaker or kept loose on the palette.

Step 3: Remove Transportation Cushion

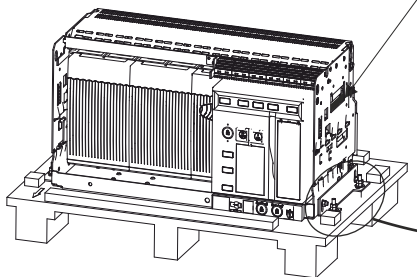

Step 4: Rack-out the breaker & remove breaker from cradle (Details in Section 2.3)
Step 5: Remove Cradle fixing bracket and nuts 1 and 2 (8 Nos.) as shown below from both left and right sides
Ensure that no loose hardware are left out in the cradle

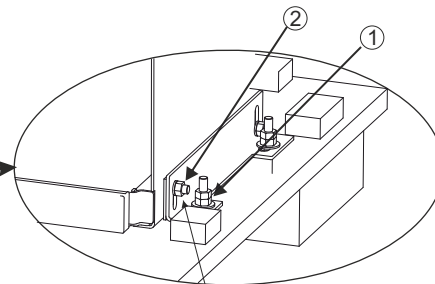

Packing - Cradle fixing bracket

1.3 Handling

CAUTION

Heavy equipment. Exercise proper care to avoid personal injury and equipment damage.

a) For Fixed breakers:

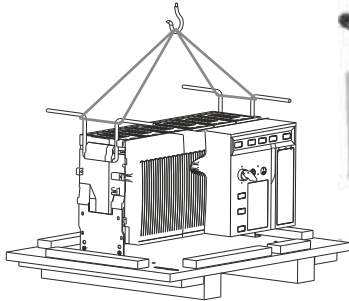

Lift the breaker using a crane. A special Lifting Handle is available (optional) to facilitate handling.

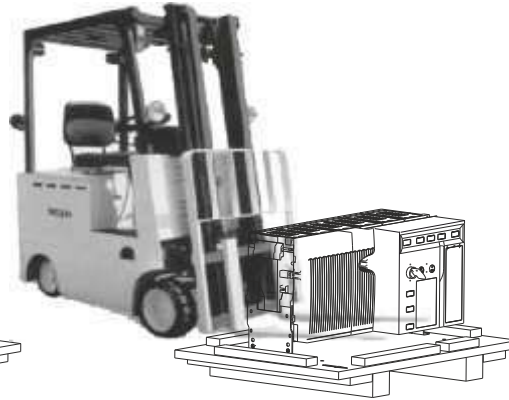

The breaker can also be transported using a Fork lift

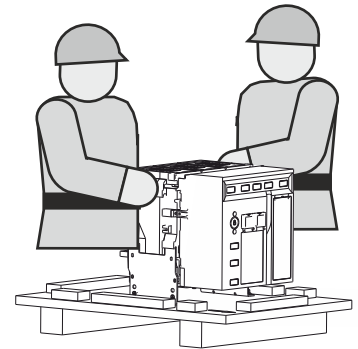

Frame 1 breakers can also be transported by 2 persons.

b) For Draw-out breakers:

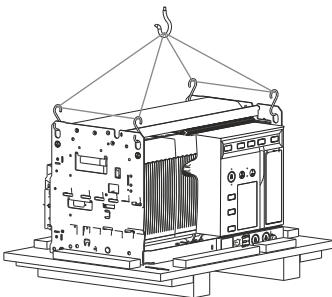

Lift the breaker using hooks at Specified places as shown above.

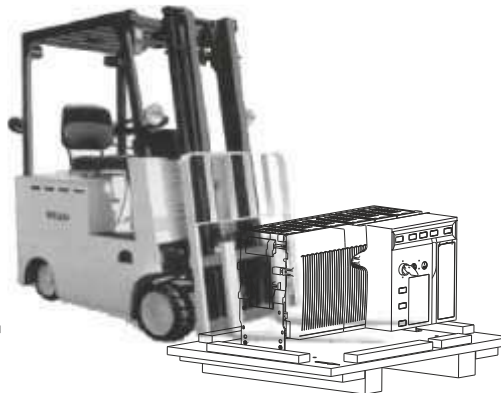

The breaker can also be transported using a Fork lift.

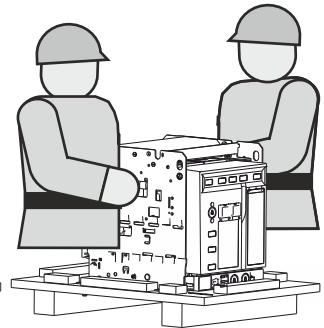

Frame 1 breakers can also be transported by 2 persons.

CAUTION

Do not lift the breaker using Facia or Terminals.

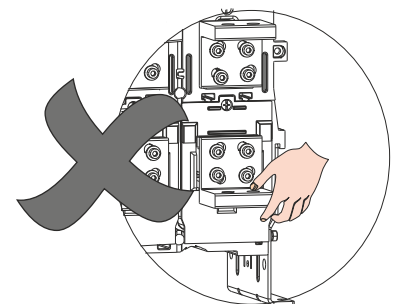
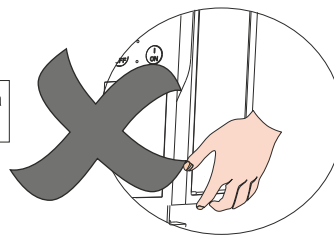

1.4 Storage

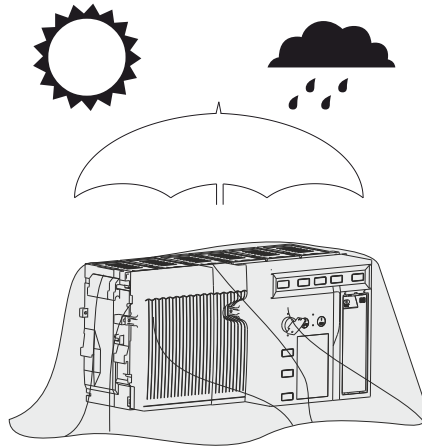

CAUTION Store the breaker in a cool, dry place, away from dusty / corrosive environment.

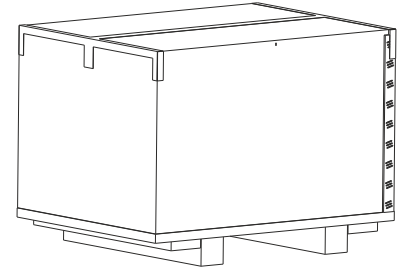

When Cradle and Breaker are not being used for a long time, pack them in the carton and store in a dry place.

Temperature Range : -40 to 85 °C.

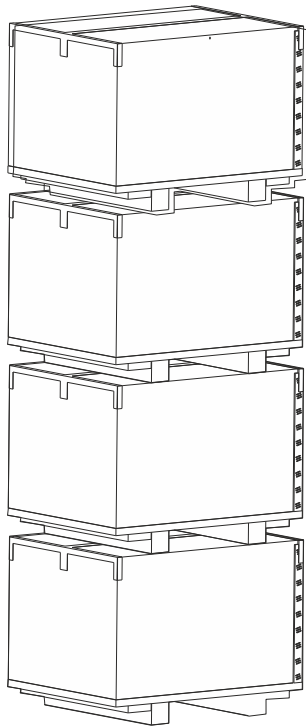

CAUTION Do not stack more than 4 breakers one above the other. Ensure that higher frame ACBs are not stacked above lower frame ACBs.

Section 2

Understanding

- 2.1 Identification
- 2.2 Exploring
- 2.3 Racking-out
- 2.4 Operating
- 2.5 Technical Data

2.1 Identification:

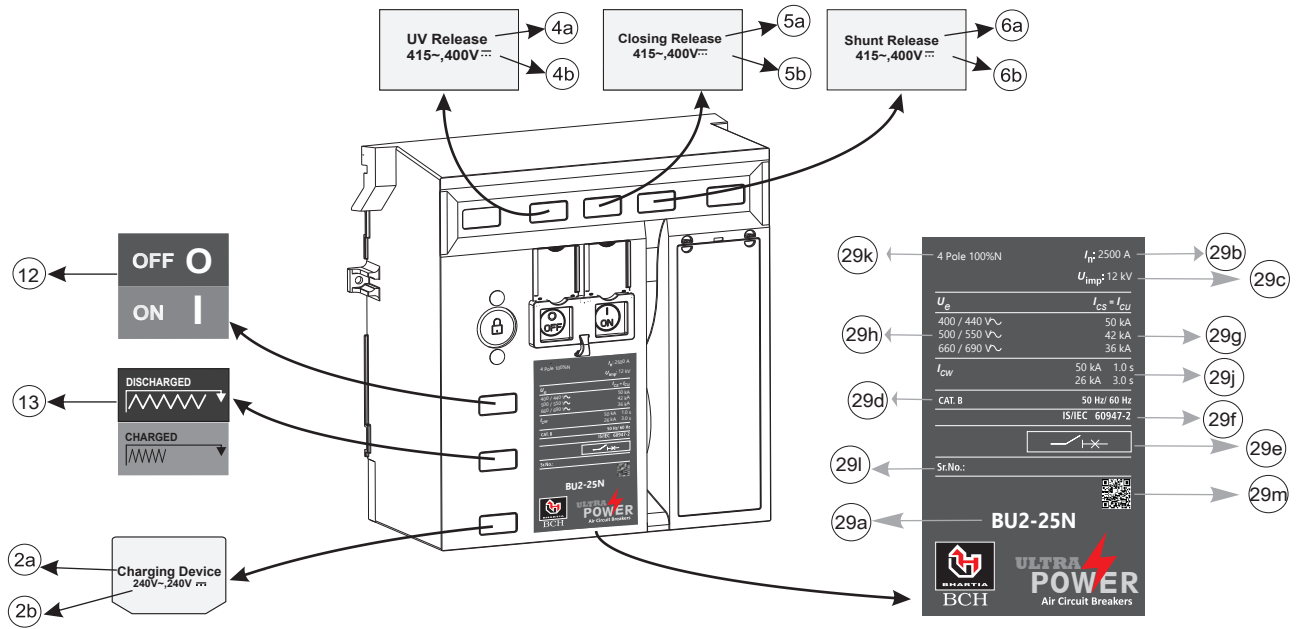

- 2a - Type designation for Electrical Charging device (ECD)
- 2b - Operating voltage for ECD
- 4a - Type designation for Under-voltage release (UVR)
- 4b - Operating voltage for UVR
- 5a - Type designation for Closing release (CR)
- 5b - Operating voltage for CR
- 6a - Type designation for Shunt release (SR/SRW)
- 6b - Operating voltage for SR/SRW
- 12 - ON-OFF indication
- 13 - Spring status indication

29a - BU2-25N

Frame Size	Rated Uninterrupted Current (In)	Version for Breaking Capacity
04	400A	N 50 kA
06	630A	S 65 kA
08	800A	H 80 kA
10	1000A	V 100 kA
12	1250A	
16	1600A	
20	2000A	
25	2500A	
32	3200A	
40	4000A	
50	5000A	
63	6300A	

- 29b - Rated Uninterrupted Current
- 29c - Rated impulse withstand voltage
- 29d - Utilization Category
- 29e - Suitability for isolation
- 29f - Standards compliance
- 29g - Rated Service breaking capacity
- 29h - Rated operational voltage
- 29i - Rated short-time withstand current
- 29j - No. of Poles & Pole details
- 29k - Serial number of ACB
- 29l - QR Code
- 29m - QR Code

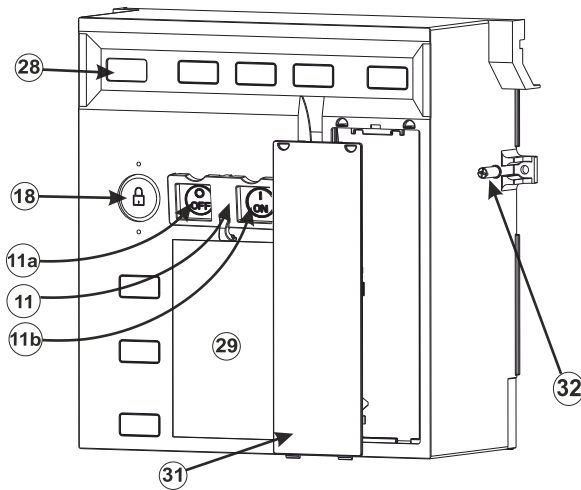

Facia

- 11 Shroud for ON-OFF Buttons
- 11a OFF button
- 11b ON button
- 18 OFF button locking
- 28 USERS' Identification location
- 29 Name plate
- 31 Cover for Protection&Control unit (P&C)
- 32 Facia fixing screw

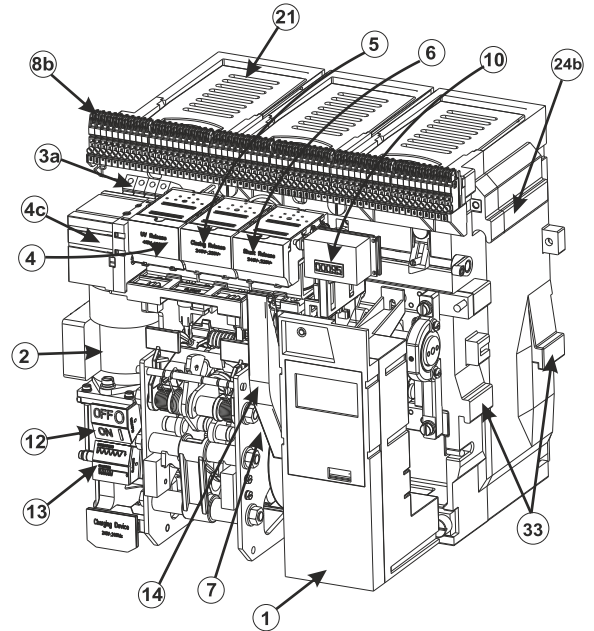

Breaker

- 1 Protection&Control Unit
- 2 Electrical Charging Device
- 3a Auxiliary Contacts
- 4 Undervoltage Release
- 4c Undervoltage Release Controller
- 5 Closing release
- 6 Shunt Release
- 7 Ready-To-Close (Microswitch)
- 8b Secondary Isolating Contacts on Breaker
- 10 Operation Counter
- 12 ON-OFF Indication
- 13 Spring Status Indication
- 14 Charging handle
- 21 Arc Chute
- 24b Lifting location on breaker
- 33 Projections for resting breaker on cradle

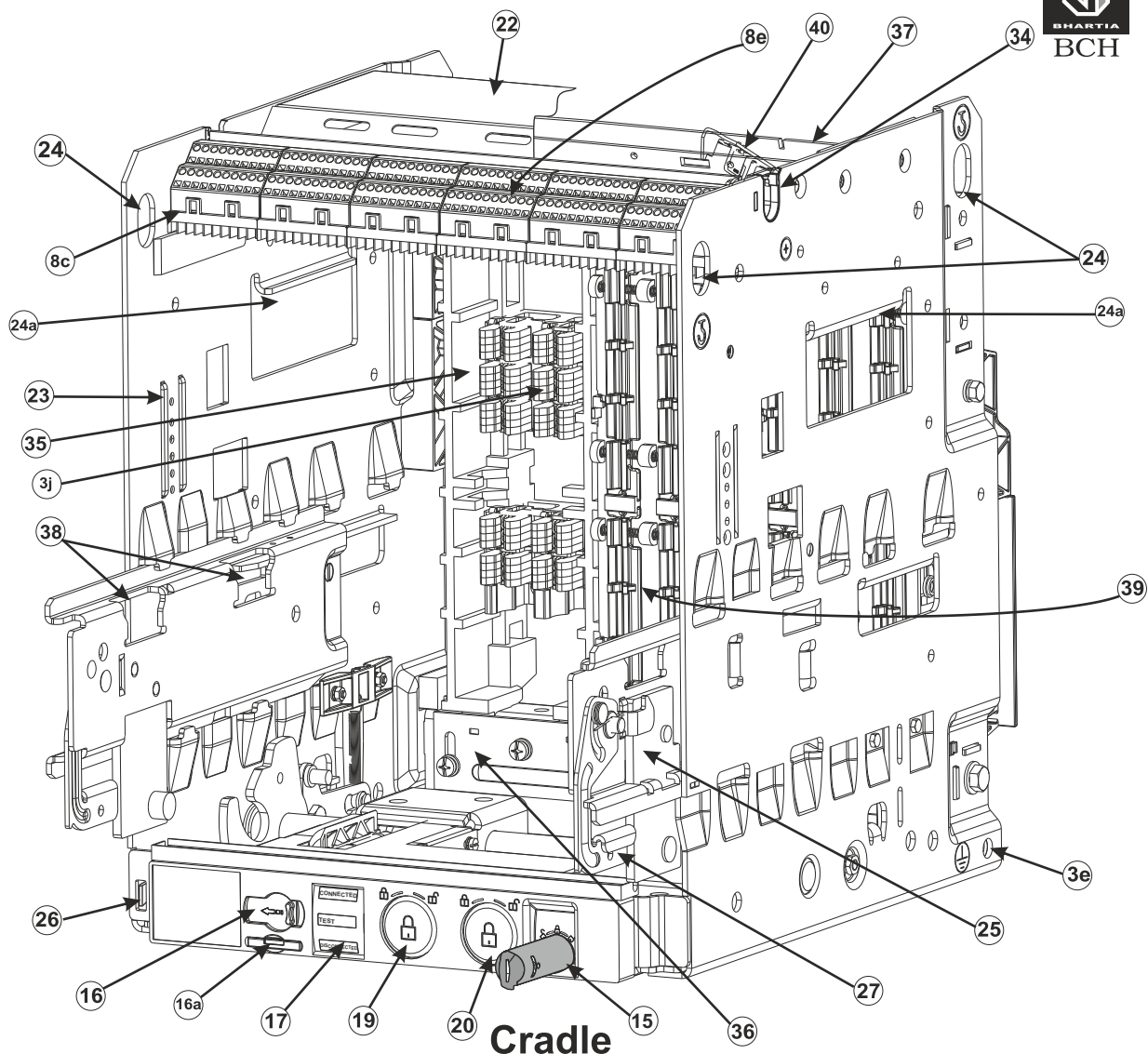

- | | | | |
|-----|--|-----|------------------------------------|
| 3e | Hole for Earthing Connection | 24 | Lifting Locations (4 nos.) |
| 3j | Jaw Contacts | 24a | Additional Lifting Locations |
| 8c | Secondary Isolating Contacts on Cradle | 25 | Withdrawal Rails |
| 8e | Electrical Position Indication | 26 | Door Racking Interlock |
| 15 | Racking Handle | 27 | Breaker Pull-out Handle |
| 16 | Smart Racking Shutter | 34 | Guide for routing Control Wiring |
| 16a | Padlock for Racking shutter | 35 | Terminal Supports |
| 17 | Position Indicator | 36 | Cradle Bottom cross-component |
| 19 | Position Lock - 1 | 37 | Cradle Top cross-component |
| 20 | Position Lock - 2 | 38 | Slot for placing breaker on Cradle |
| 22 | Arc Shield | 39 | Safety Shutter |
| 23 | Rating Error Prevention | 40 | Door Interlock |

2.3 Racking-out



For D/O Breakers remove the Transportation Cushion (2 Nos.) & its instruction label, before doing racking operation of the breaker.

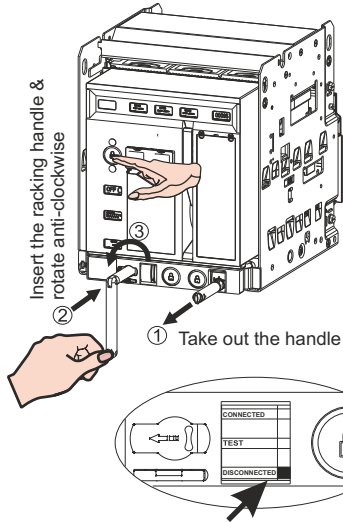
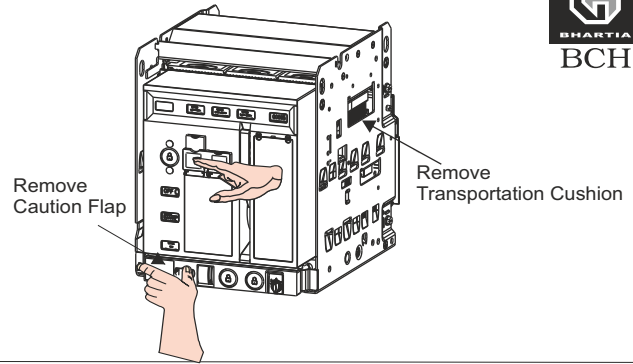

Keeping OFF button (11a) pressed, open the Racking Shutter (16). In case Breaker is out of the panel or the panel door is open, gently press Racking Interlock (26) to defeat it.

Note: Once racking shutter is opened, the breaker can not be closed, even by an electrical closing command.

Rack-out the breaker to Disconnected position.

Note: After removing the racking handle (15), the racking shutter automatically recloses only in distinct 'Connected' / 'Test' and 'Disconnected' positions (17). Hence, Breaker cannot be closed in any Intermediate positions to ensure User safety.

CAUTION Excessive, forceful Racking-out beyond Disconnected position may lead to Product damage.

Pull the breaker out using pull-out handles (27).

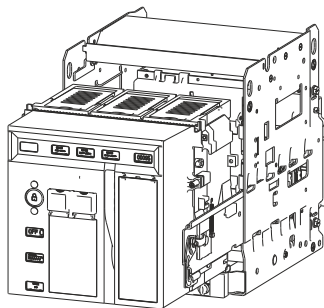
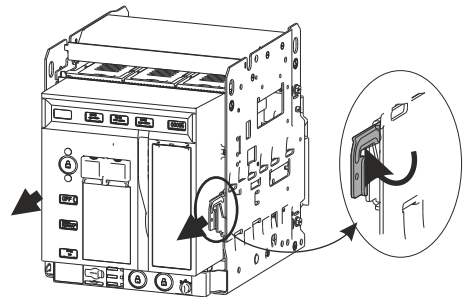

In Maintenance position, Breaker can be removed from the cradle by two persons (Fr.1) or by using a crane (Fr.2 & Fr.3) .

Please refer 1.3 Handling.

2.4. Operating:

Initially, the Breaker is **OFF**  and Spring is 

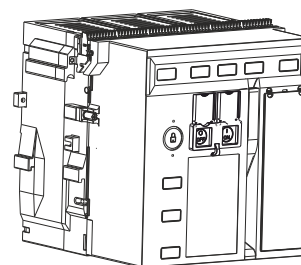

Charge the Main spring through multiple strokes of charging handle (14)

Now the Breaker is **OFF**  and Spring is 

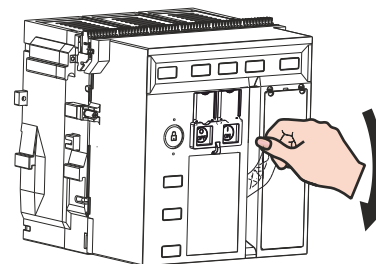

Push 'ON' button (11b) to close the breaker.

Now, the breaker is **ON**  and spring has 

In this situation, spring can be charged again for next operation.

Breakers equipped with Undervoltage (4) cannot be normally closed unless the release is energized.

ACB's Undervoltage release has a special feature, by which one can still check the operation. (Refer. Page 4-10 for details)

Arc Chute Interlock prevents closing of breaker, if any arc chute is missing or not secured properly

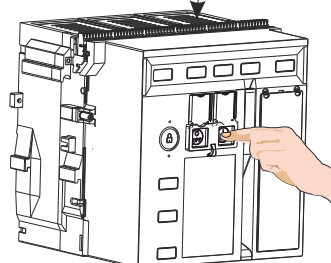

Push 'OFF' button (11a) to trip the breaker.

Now, the breaker is **OFF**  and spring is 

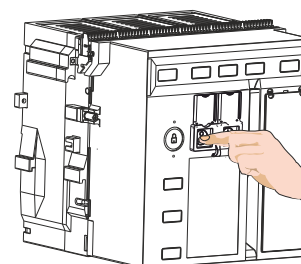

2.5 Technical Data



Unit	Symbol	
V	Ue	Upto 690
V	Ui	1000
kV	Uimp	12
kV	Uimp	4
		3 & 4 (50, 100, 200% N)
		Yes
		IP 53 / IP 54*
		4
		B
-25°C to 70°C		
IK 08 / IK 10*		
2 Hz to 13.2 Hz, +/-1mm displacement		
13.2 Hz to 100 Hz, 0.7g acceleration		
15g for 11 ms (Half-sine wave pulse)		
IS/IEC 60947-2, EN 60947-2, IEC 60947-2		

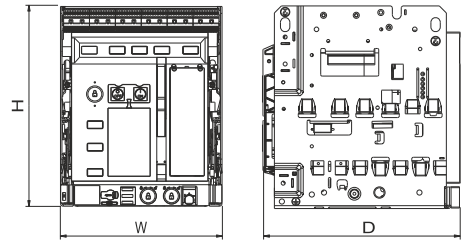

H : Height
W : Width
D : Depth with flat terminals

			FRAME			I						II						III													
Rating specific parameters			Neutral	Unit	Symbol	400-1600			2000			2500			400-2500			3200			4000			400-5000		6300**					
Rated uninterrupted Current at 50 deg. C				A	In																										
Versions						N	S	H	N	S	H	S	H	N	S	H	N	S	H	N	S	H	S	H	S	H	H	V	H	V	
Rated Ultimate	415/440V ~ 50/60 Hz		kA	Icu	50	65	80	50	65	80	65	80	50	65	80	50	65	80	50	65	80	65	80	80	100	80	100	80	100		
	500/550V ~ 50/60 Hz		kA		42	55	65	42	55	65	55	65	42	55	70	42	55	70	55	70	70	85	70	85	70	85	70	85			
	660/690V ~ 50/60 Hz		kA		36	50	55	36	50	55	50	55	36	50	55	36	50	55	50	55	55	65	65	75	65	75	65	75			
Rated Service	415/440V ~ 50/60 Hz		kA	Ics	100% Icu																										
	500/550V ~ 50/60 Hz																														
	660/690V ~ 50/60 Hz																														
Rated Short	0.5 sec		kA	Icw	50	65	80	50	65	80	65	80	50	65	80	50	65	80	65	80	50	65	80	65	80	80	100	80	100	80	100
	1.0 sec		kA		50	65	80	50	65	80	65	80	50	65	80	50	65	80	65	80	50	65	80	65	80	80	100	80	100	80	100
	3.0 sec		kA		26	36	44	26	36	44	36	44	26	44	26	44	50	26	44	50	44	50	44	50	44	50	65	75	65	75	
Rated S.C Making Capacity	415/440V ~ 50/60 Hz		kA	Icm	105	143	176	105	143	176	143	176	105	143	176	105	143	176	105	143	176	143	176	143	176	143	176	220	176	220	
	500/550V ~ 50/60 Hz		kA		88	121	143	88	121	143	121	143	88	121	88	121	154	88	121	154	121	154	121	154	143	154	187	154	187		
	660/690V ~ 50/60 Hz		kA		76	105	121	76	105	121	105	121	76	110	76	110	121	76	110	121	110	121	110	121	110	121	143	165	143	165	
Break Time				ms	25																										
Close Time					60																										
Dimensions	Fixed ACB	Width - 3P		mm	W	347						447						647													
		Width - 4P	100%	mm	W	447						581						847													
		Depth		mm	D	324						324						334													
		Height		mm	H	430																									
	Drawout ACB	Width - 3P		mm	W	347						447						647													
		Width - 4P	100%	mm	W	447						581						847													
		Depth		mm	D	421						421						431													
		Height		mm	H	433																									
Mechanical Life - With Maintenance				no. of cycles	20000						15000						10000														
Frequency of Operations - Mechanical				cycles/hour	60																										
Electrical Life - Without Maintenance#				no. of cycles	10000						5000			5000						5000			2000								
Frequency of Operations - Electrical				cycles/hour	40																										
Pitch I/C - O/G				mm	105																										
Pitch	Ph-Ph		mm	100						133						200															
	Ph-N	100%	mm	100						133						200															
Weight	Fixed ACB	3P		kg	60	62	69	67	64	69	69	69	76	76	83	83	83	83	83	83	83	83	130	130	138	138					
	ACB	4P	100%	kg	73	76	85	79	79	85	85	85	85	120	120	132	132	132	132	132	132	143	143	170	170						
	Drawout ACB	3P		kg	87	91	103	94	98	103	103	103	103	113	113	125	125	125	125	125	125	136	136	198	198	227	227				
	ACB	4P	100%	kg	104	109	127	112	115	127	127	127	127	168	168	181	181	181	181	181	181	195	195	248	248	285	285				

* With Special Cover
**40 deg C
With Maintenance Electrical Life = Mechanical Life

Section 3

Installing

- 3.1 Mounting & Door cut-out
- 3.2 Termination
- 3.3 Loading in Panel
- 3.4 Control circuit connections

Mounting in a Panel

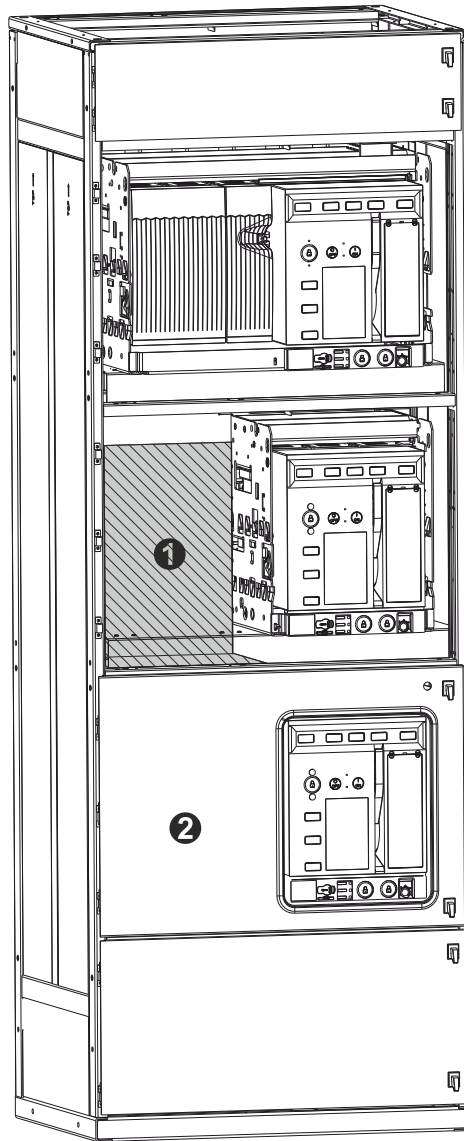

General Information:

- 1 Ultra Power ACB System of Breakers have common Height and Depth across the range to facilitate Panel design.
- 2 Ultra Power ACB System of Breaker's front facia is Right aligned thereby giving uniform panel appearance. This feature also leads to optimum utilization of panel space, inside the panel as well as on the door.
- 3 While Left hand side Hinge is recommended, Ultra Power ACB System of Breakers also supports Right hand side hinged panel design.

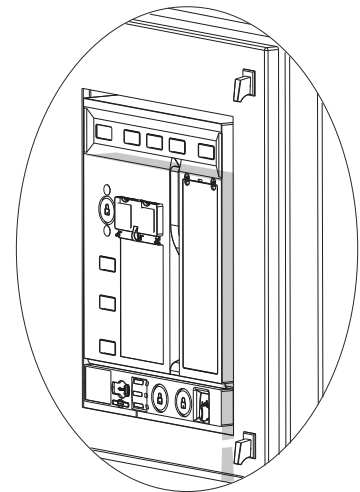

- 4 Ultra Power ACB System of Breaker's front facia should project 7 mm outside the panel door, when in Connected position

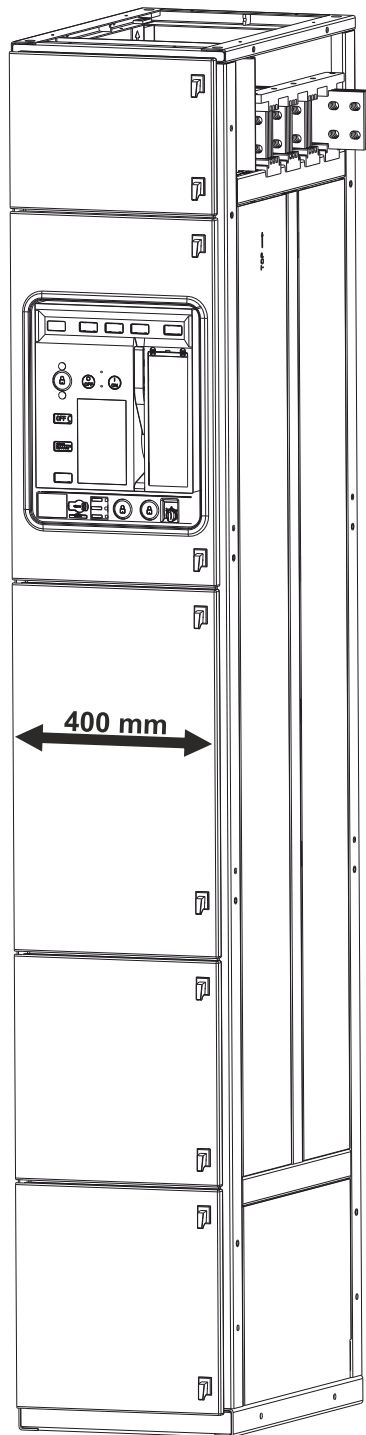

Frame 1, 3 Pole Ultra Power ACB System of breaker can be fitted in a 400mm wide panel.

At the same time, Ultra Power ACB System of breakers can accommodate Aluminium Termination.

Ultra Power ACB System of breakers in other frame sizes also support compact panels,

Frame size	No. of Poles	Min. Panel width
1	3	400 mm
1	4	500 mm
2	3	500 mm
2	4	700 mm
3	3	700 mm
3	4	900 mm

Note: 4-pole ACBs considered above are with max. 100% Neutral Rating.

Actual panel dimensions depend on a number of other factors viz.

- Ventilation of room
- IP degree of panel
- Feeder configuration & loading
- Link layout
- Size of Power cables, etc.

Mounting

400A-2000A N & 400A-2500A S/H Fr.1 3P



Fixed Circuit Breaker

VERSION	DIM. B
400-2000A N & S	326
400-2000A H	324
2500A S & H	324

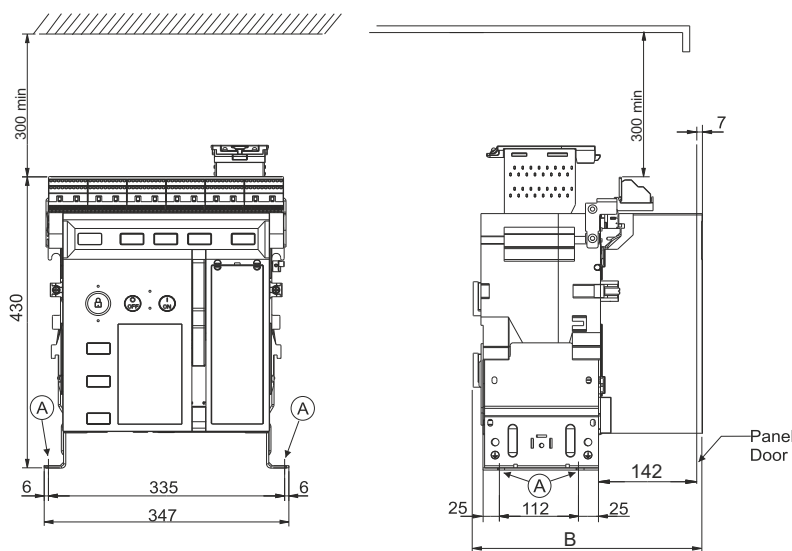

Drawout Circuit Breaker

VERSION	DIM. C (min.)	DIM. C* (min.)
N, S, H	45	70

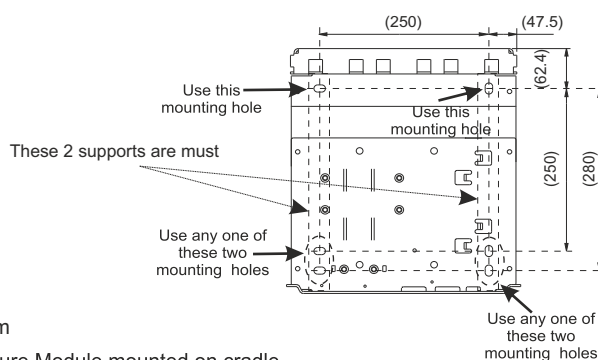
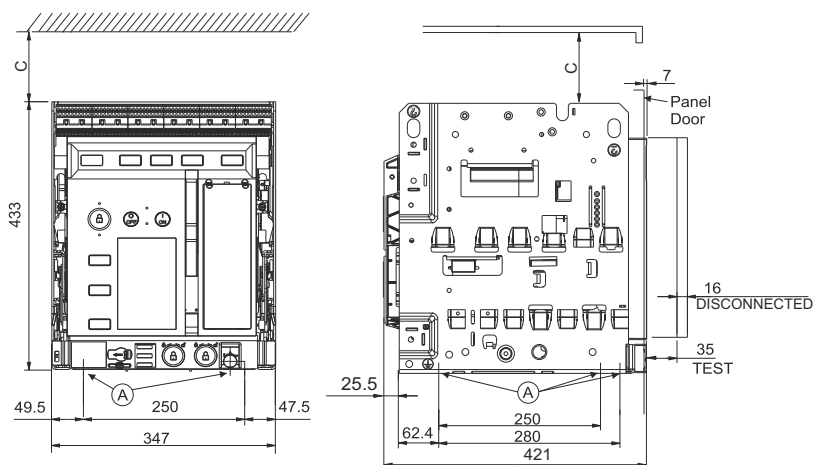

All Dimensions in mm

* In case of Temperature Module mounted on cradle

Mounting holes suitable for M10 / Equivalent BS bolt

Mounting

400A-2000A N & 400A-2500A S/H Fr.1 4P (100% N)



Fixed Circuit Breaker

VERSION	DIM. B
400-2000A N & S	326
400-2000A H	324
2500A S & H	324

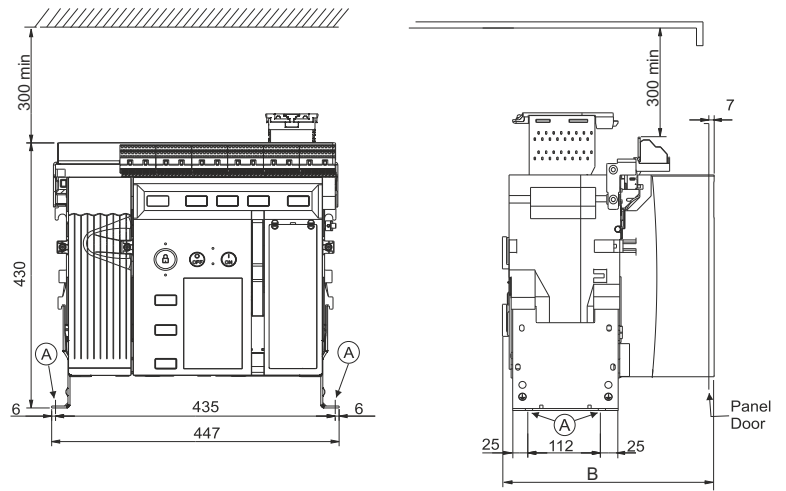

Drawout Circuit Breaker

VERSION	DIM. C (min.)	DIM. C* (min.)
N, S, H	45	70

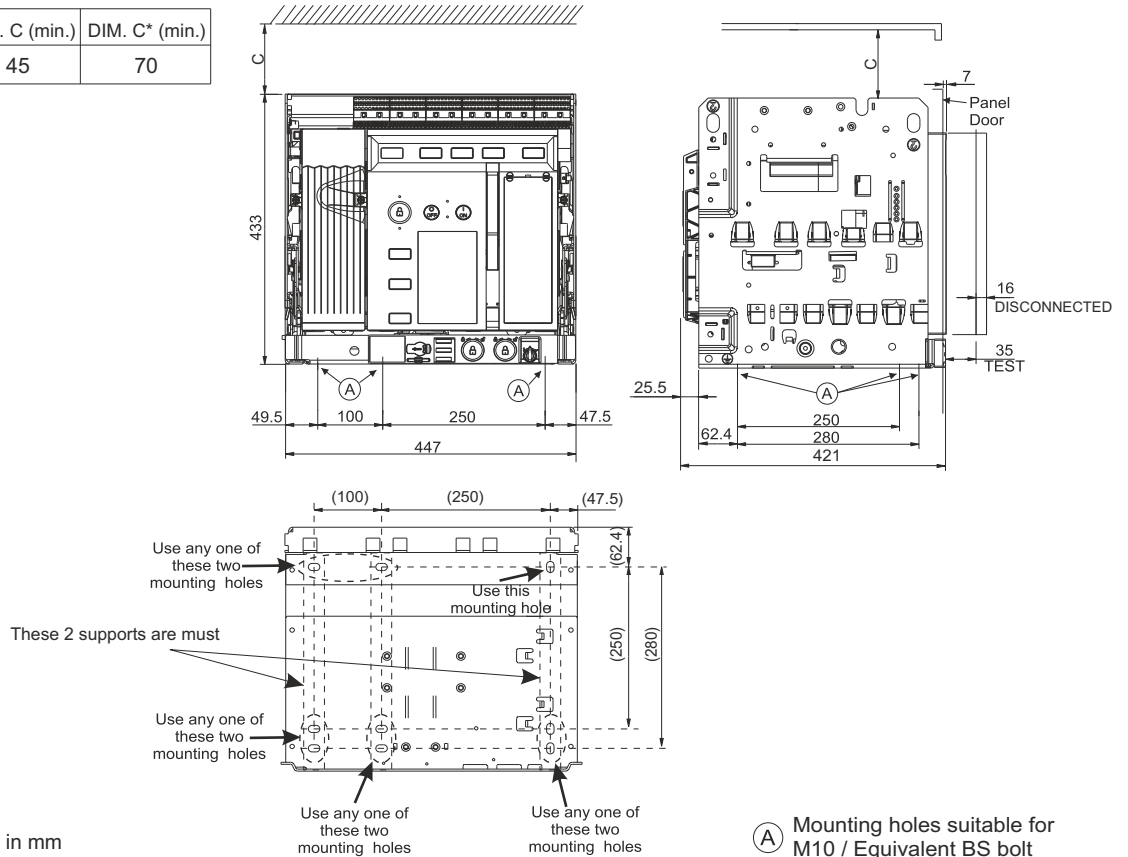

All Dimensions in mm

* In case of Temperature Module mounted on cradle

Mounting

400A-4000A N*/S/H Fr.2 3P

Fixed Circuit Breaker

VERSION	DIM. B
400-2500A N/S	326
3200-4000A N*/S	324
400-4000A H	324

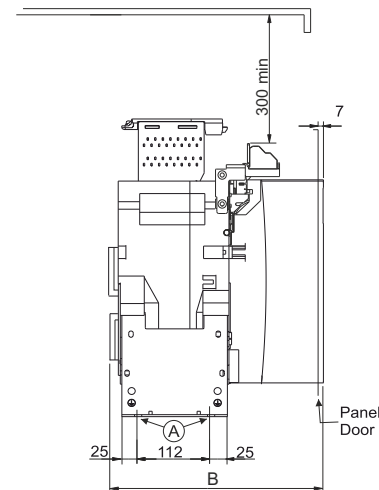
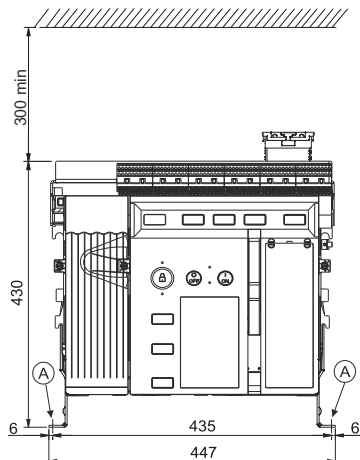

* Available till 3200A.

Drawout Circuit Breaker

VERSION	DIM. C (min.)	DIM. C* (min.)
N, S, H	45	70

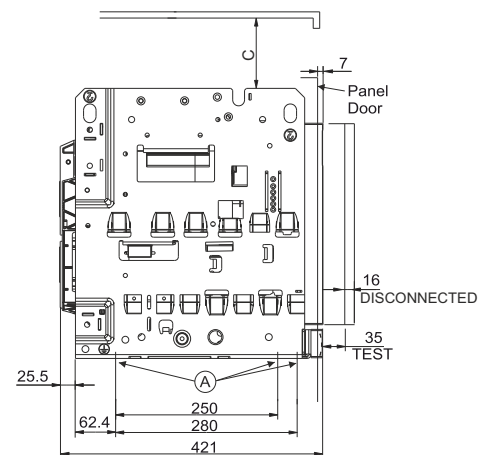
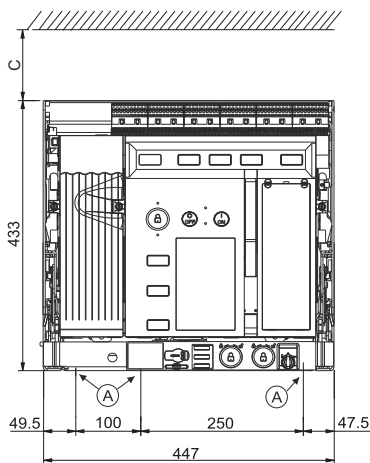

These 2 supports are must

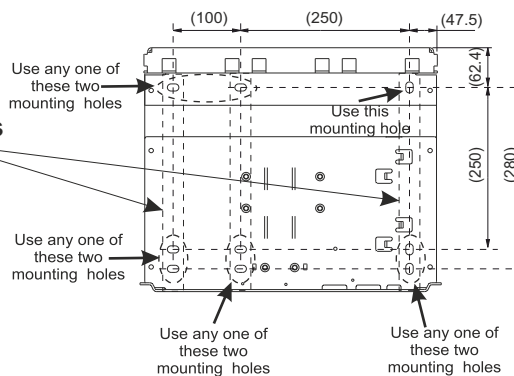

All Dimensions in mm

* In case of Temperature Module mounted on cradle

Ⓐ Mounting holes suitable for M10 / Equivalent BS bolt

Mounting

400A-4000A N*/ S/ H Fr.2 4P (100% N)

Fixed Circuit Breaker



VERSION	DIM. B
400-2500A N/S	326
3200-4000A N*/S	324
400-4000A H	324

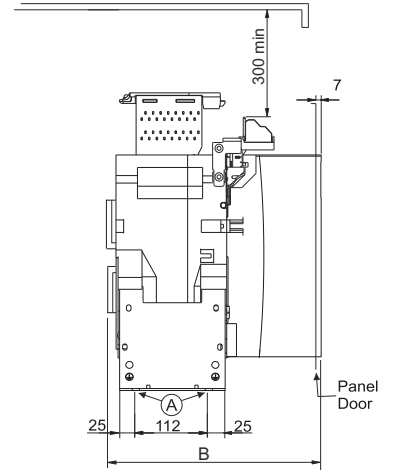
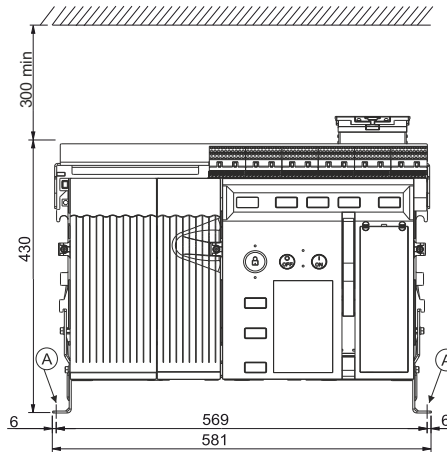

* Available till 3200A

Drawout Circuit Breaker

VERSION	DIM. C (min.)	DIM. C* (min.)
N, S, H	45	70

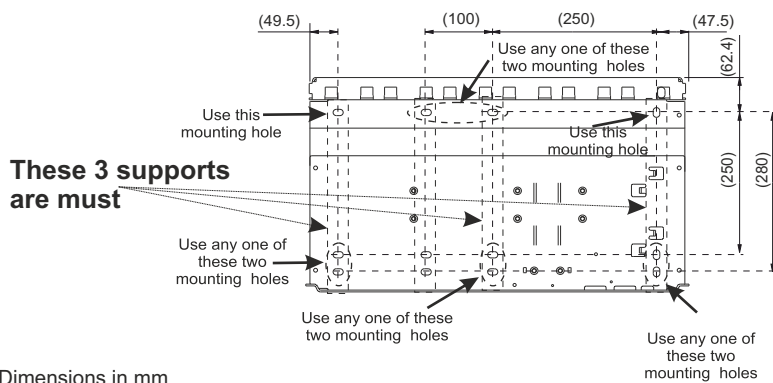
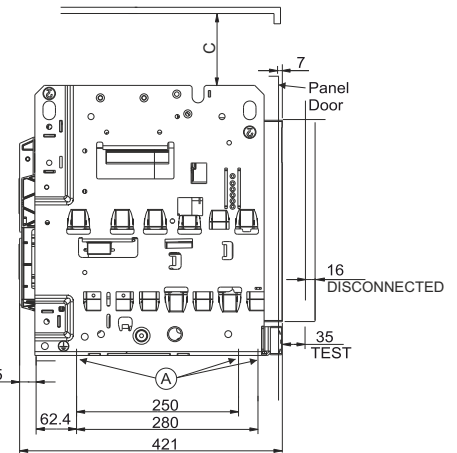
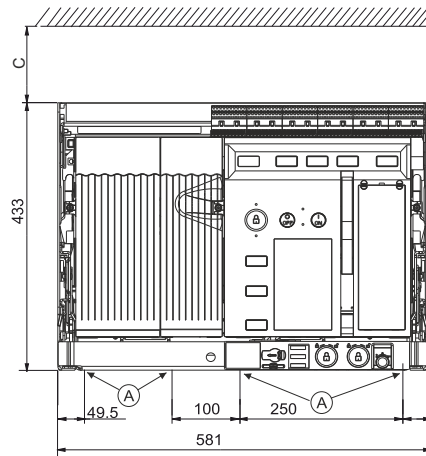

All Dimensions in mm

* In case of Temperature Module mounted on cradle

(A) Mounting holes suitable for M10 / Equivalent BS bolt

Mounting

400A-6300A H/V Fr.3 3P

Fixed Circuit Breaker

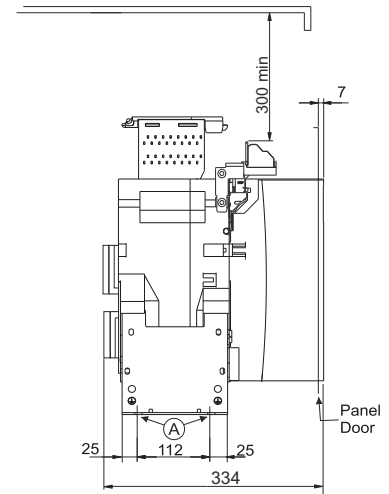
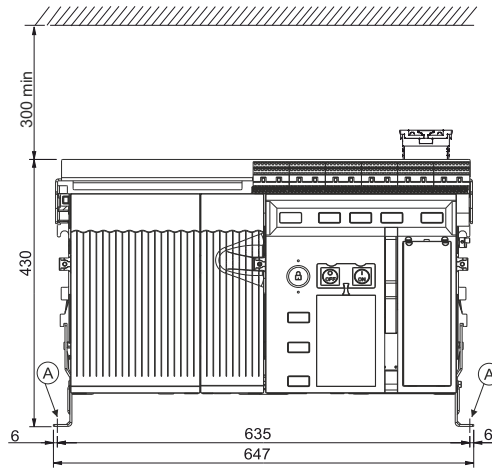

* Available till 4000A

Drawout Circuit Breaker

VERSION	DIM. C (min.)	DIM. C* (min.)
H, V	45	70

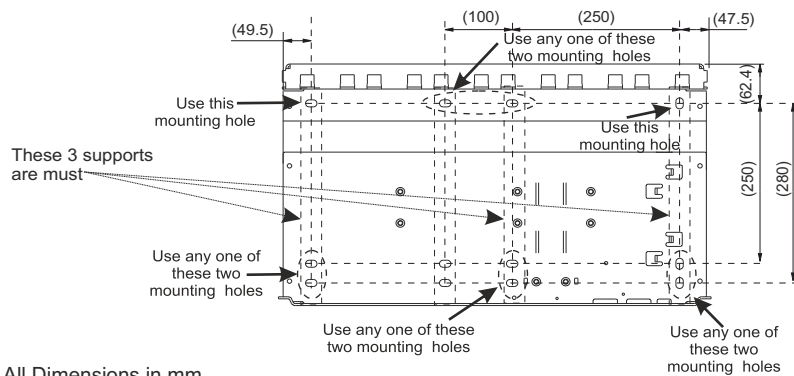
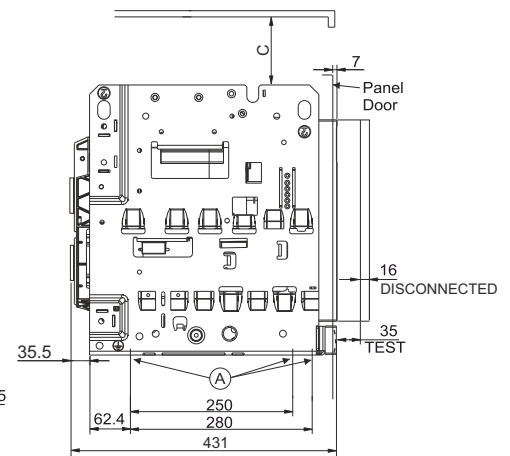
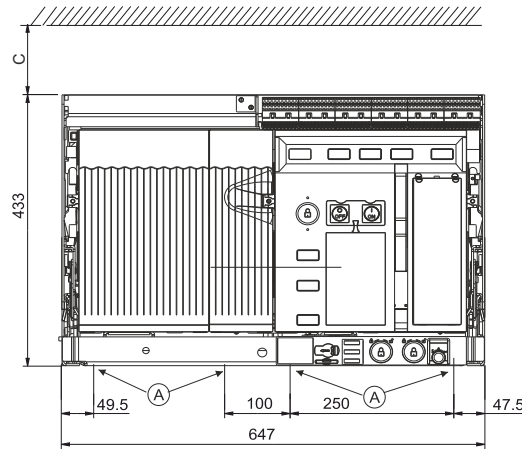

All Dimensions in mm

* In case of Temperature Module mounted on cradle

(A) Mounting holes suitable for M10 / Equivalent BS bolt

Mounting

400A-6300A H/V Fr.3 4P (100% N)

Fixed Circuit Breaker

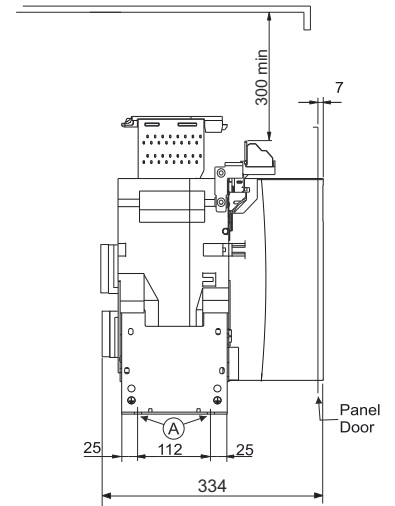
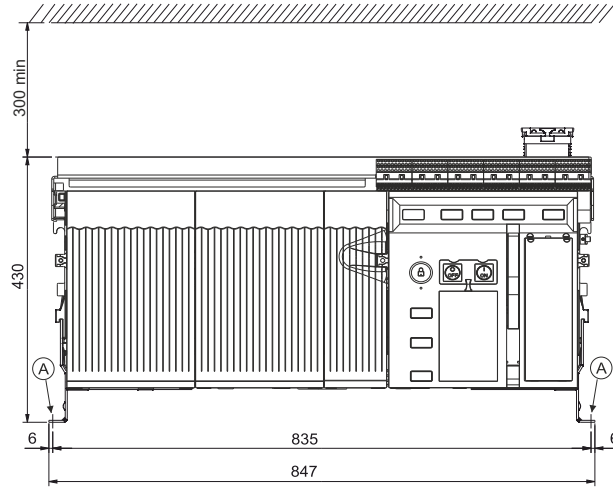

* Available till 4000A

Drawout Circuit Breaker

VERSION	DIM. C (min.)	DIM. C* (min.)
H, V	45	70

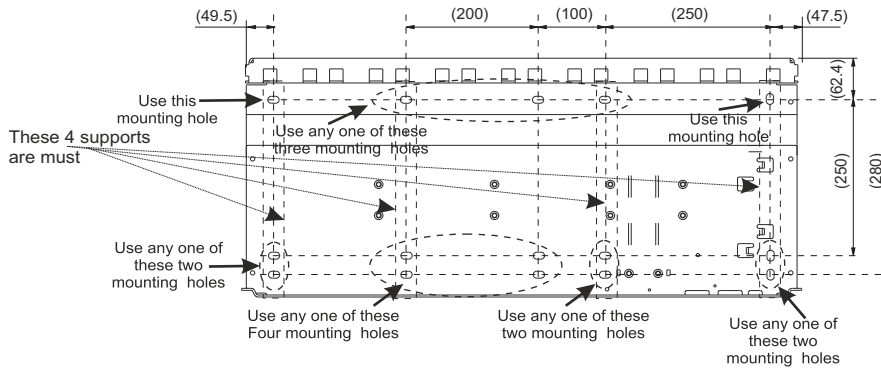
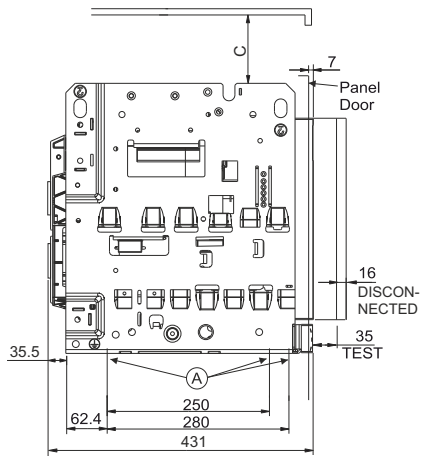
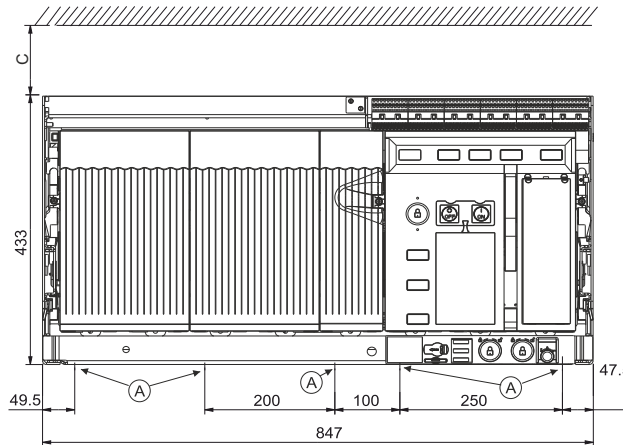

Ⓐ Mounting holes suitable for M10 / Equivalent BS bolt

All Dimensions in mm

* In case of Temperature Module mounted on cradle

Door Cutout Details



All Dimensions in mm

Fixed Circuit Breaker

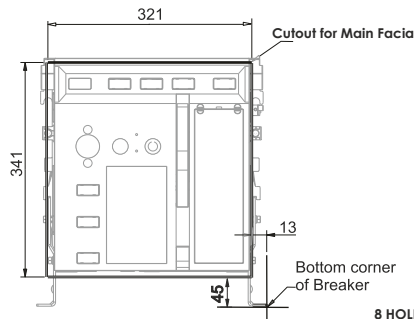
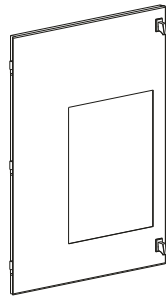

(Bezel overall Dims W=371XH=391; 25mm around the cutout)

FIXED ACB BEZEL FIXING DRILLING PLAN

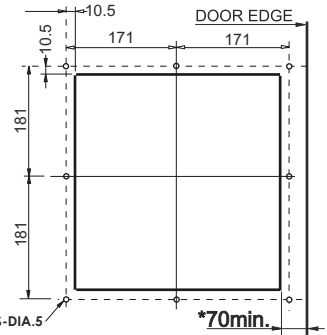

Draw-out Circuit Breaker with Left hand side hinge:

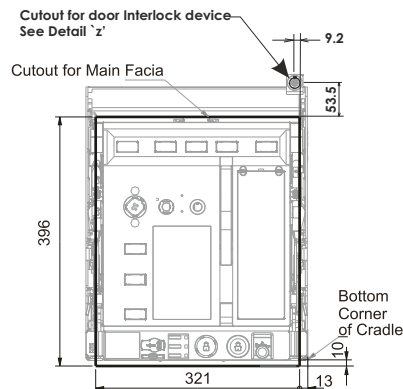
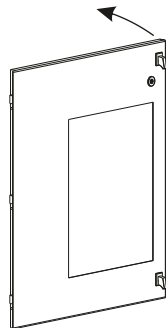

(Bezel overall Dims W=371XH=446; 25mm around the cutout)

D/O ACB BEZEL FIXING DRILLING PLAN

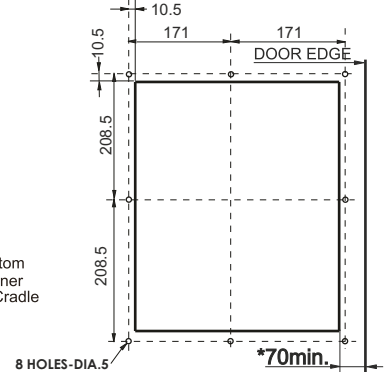

Draw-out Circuit Breaker with Right hand side hinge:

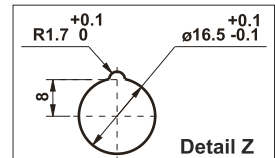
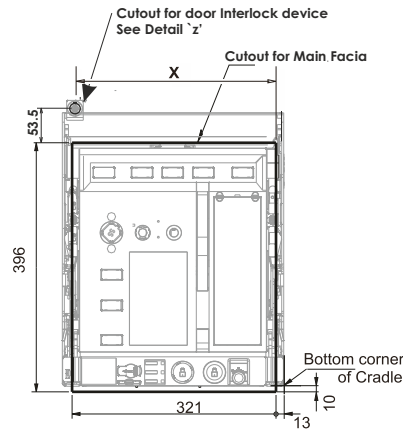
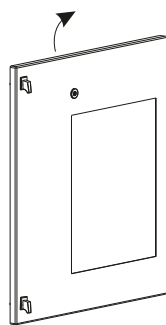

Frame size	Poles	Dimension 'X'
I	3	311.8
	4	411.8
II	3	411.8
	4	545.8
III	3	611.8
	4	811.8

Refer page 2-6 for identifying frame size of the breaker

Fixing Door Sealing Frame:

Function: To provide Ingress protection

Installation: Fix the sealing (Bezel assy.) frame on the panel door by provided M4x8mm length Screws at 8 places from the rear side of panel door.

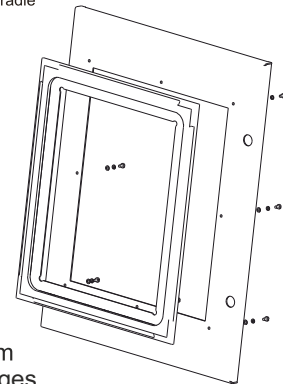

*For bezel assembly fixing, 70 mm. min. dimension is required from the fascia cutout to Panel door edge for both (RHS & LHS) side hinges .

3.2 Termination

Termination on Draw-out Breakers

System of ACB terminals offer more contact area to accept Aluminium links.

System of ACBs Universal flat terminals greatly facilitate termination. These terminals directly support all commonly used types of termination as shown in adjoining figure.

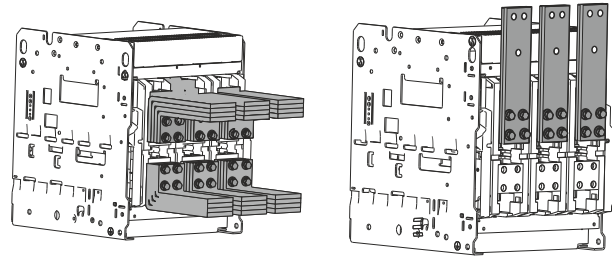

System of ACB's are having inbuilt nut plates (M12 Threading) in Cradle terminal, to facilitate termination.

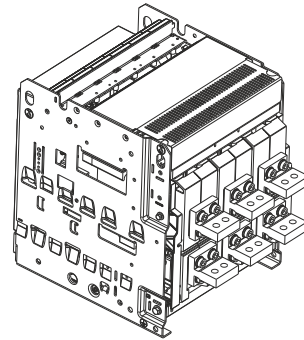

Terminal Adaptor:

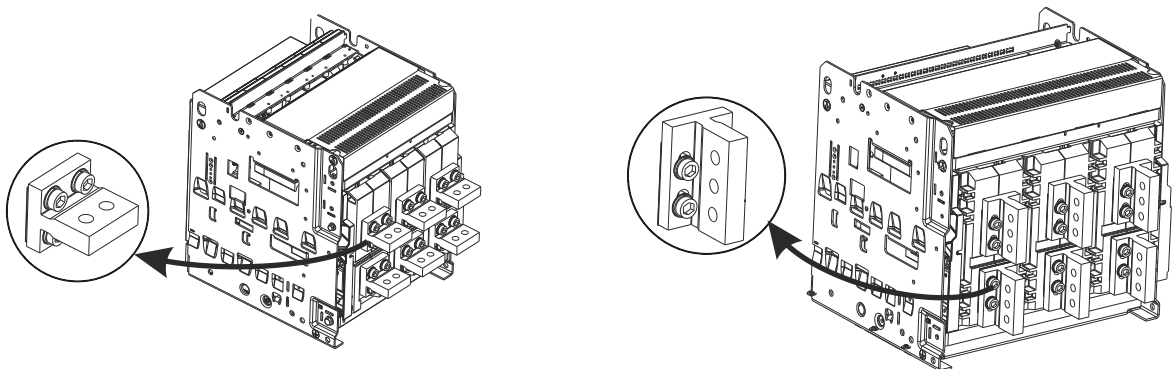



























For Fr-1, Terminal Adapter installation.
In Fr-3 use equalizer for vertical & a single Adaptor for horizontal between two poles.

Installation of Terminal Adapter for frame 2 400-4000A

3.2 Termination

Details of Terminal adaptors for Fixed and Draw - out ACBs

Draw Out Version		Frame 1			Frame 2			Frame 3		
		400A-2000A	2500A	400A-3200A	4000A	400A-4000**A	5000**A	6300A		
Horizontal		Width : 65mm BLCA609630000	Vertical termination recommended		Width : 98mm BLCA609640000		Width : 165mm BLCA609660000		Vertical termination recommended	
		Height : 65mm BLCA609630000			Width : 100mm BL603160000		Width : 165mm BL600730000			
Vertical		Height : 65mm BLCA609630000		Height : 98mm BLCA609640000			Height : 125mm BL60128000Q(1EA)		Height : 150mm BL60965000Q(1EA)	

Fixed Version		Frame 1			Frame 2			Frame 3		
		N/S	H	S/H	N/S	N/S/H	S/H	H/V		
Horizontal		400A-2000A		2500A						
	Width : 65 mm BL609670000	400A-2000A	Width : 65 mm BL609680000	Vertical termination recommended	400A-2500A	400A-3200A	4000A	400A-4000**A	5000**A	
Vertical		400A-2000A		2500A						
	Width : 65 mm BL609670000	400A-2000A	Width : 65 mm BL609680000	Vertical termination recommended	400A-2500A	400A-3200A	4000A	400A-4000**A	5000**A	
	Height : 65 mm BL609670000	Height : 65 mm BL609680000	Height : 100 mm BL609760000	Height : 100 mm BL601220000	Height : 100 mm BL609770000	Height : 150 mm BL604170000	Height : 125 mm BL604180000	Height : 150 mm BL603470000 (1EA)		

**Frame-3, 4000A and 5000A, horizontal for bus-coupler ACBs only

Termination Methods:

For Fixed Breakers:

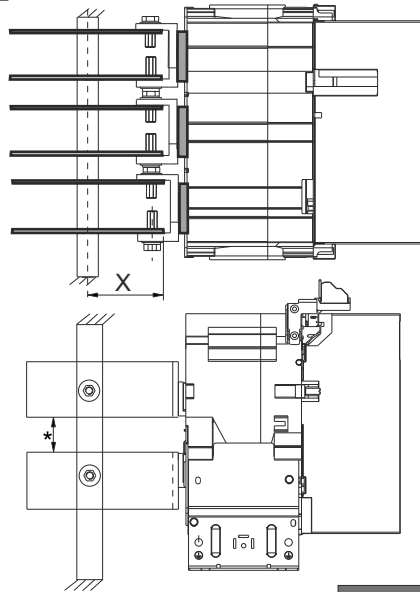

X = 100 - 150 mm

CAUTION

Inadequate termination support may result in overheating & adversely affect performance during short circuit conditions.

For Draw-out Breakers:

With Universal Terminals

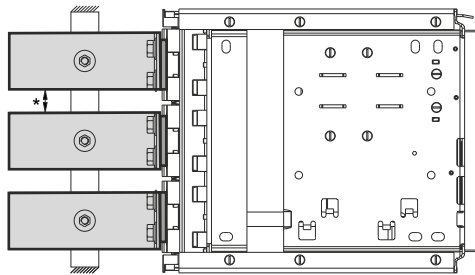

With Terminal Adaptor

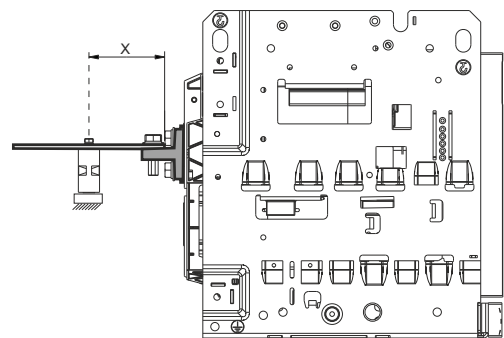
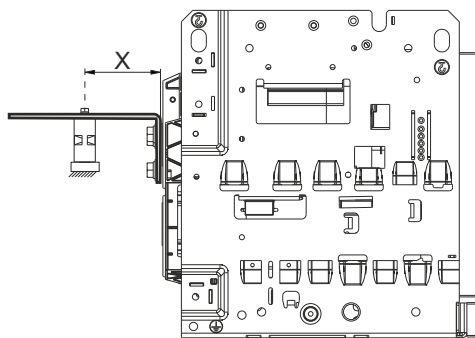
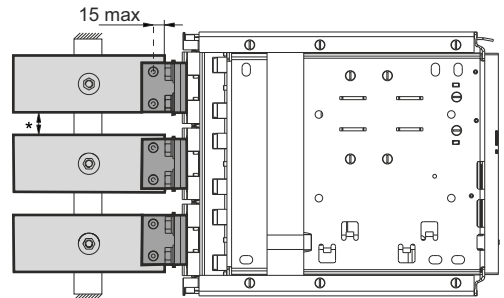

X = 100 - 150 mm

* Maintain adequate clearance between links as per applicable standards.

Termination - Fixed Breakers

Flat Termination 400A-1600A N/S/H Fr.1-3P

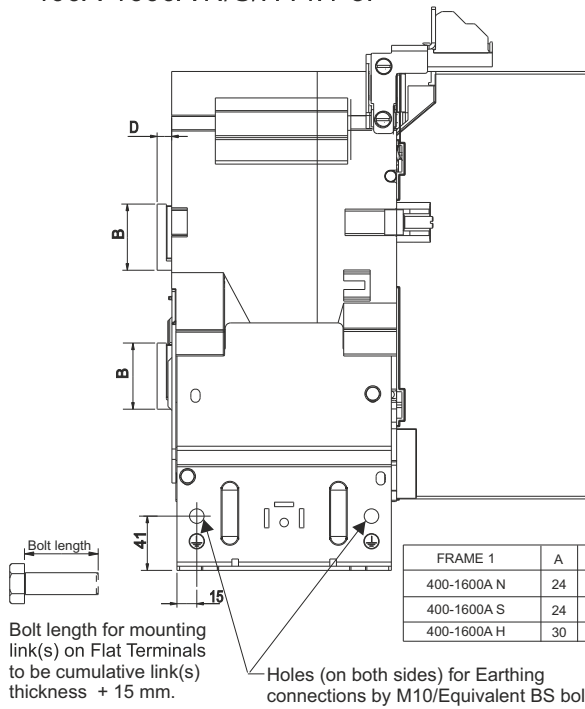

FRAME 1	A	B	C	D
400-1600A N	24	50	50	11
400-1600A S	24	50	65	11
400-1600A H	30	55	65	9

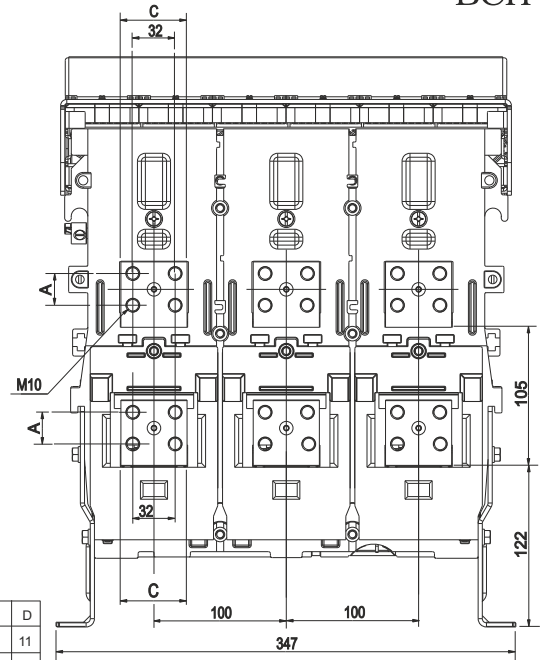

M10 bolts to be used for link termination
Tightening torque: 3.0 kgfm

Horizontal Termination 400A-1600A N/S/H Fr.1-3P 2000A N/S/H Fr.1-3P

BREAKER RATING	ADAPTOR CAT. No.
400-2000A N/S	BL609670000
400-2000A H	BL609680000

BREAKER RATING	DIMENSION A
400 - 2000A N/S	74
400 - 2000A H	72

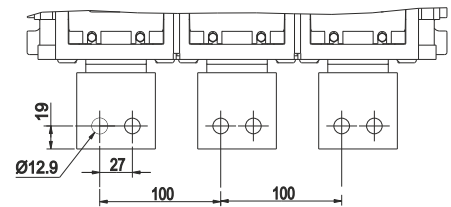
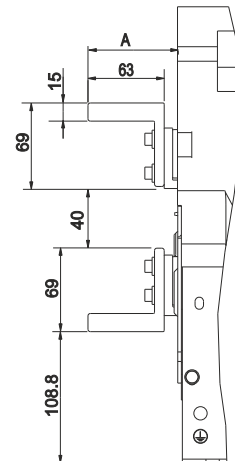
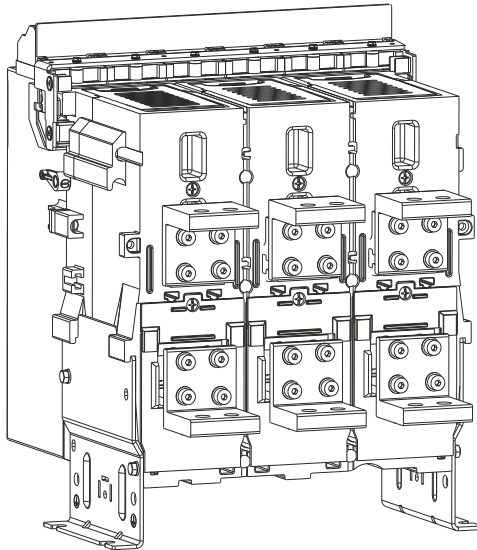

M12 / Equivalent BS bolts to be used for link termination
Tightening torque: 3.2 kgfm

Termination - Fixed Breakers

Vertical Terminals

400A-1600A N/S/H Fr.1-3P
2000A N/S/H Fr.1-3P

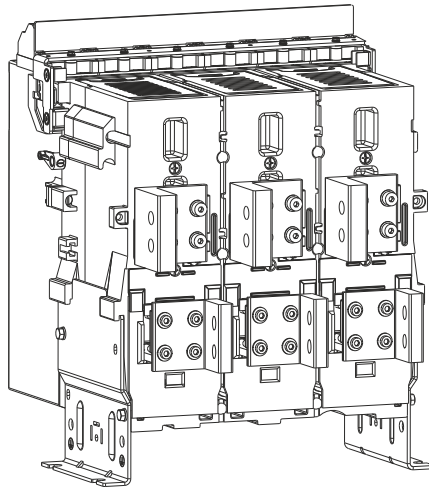

BREAKER RATING	ADAPTOR CAT NO.
400 - 2000A N/S	BL609670000
400 - 2000A H	BL609680000

BREAKER RATING	DIMENSION A
400 - 2000A N/S	74
400 - 2000A H	72

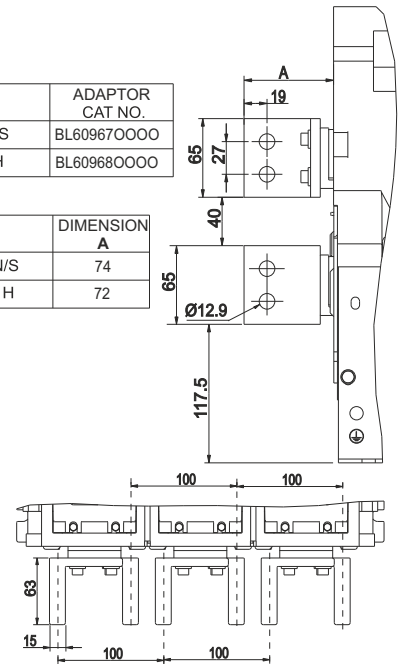

M12 / Equivalent BS bolts to be used for link termination
Tightening torque: 3.2 kgfm

Vertical Terminals

2500A S/H Fr.1-3P
(Adaptor-BL609760000)

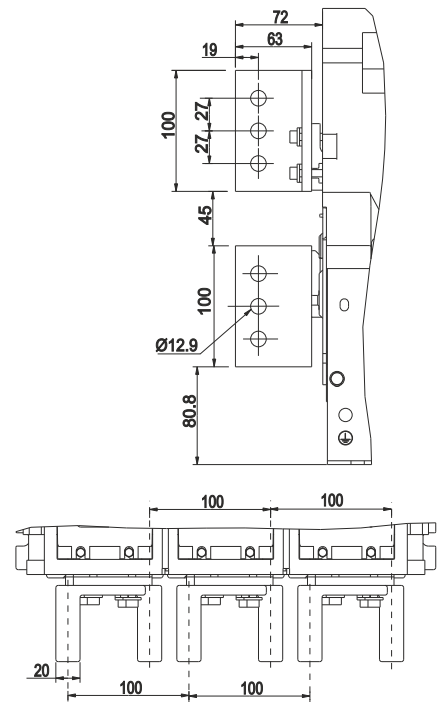
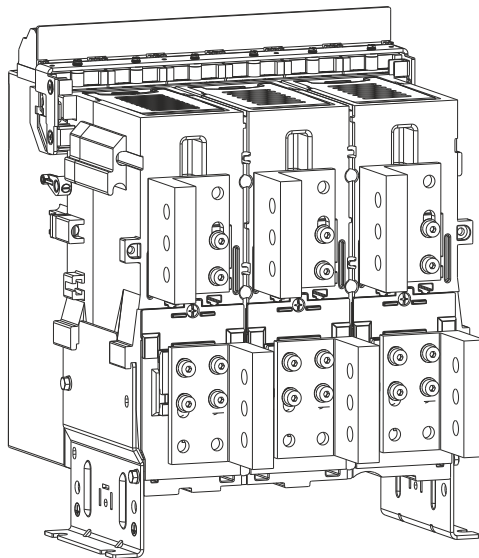

M12 / Equivalent BS bolts to be used for link termination
Tightening torque: 3.2 kgfm

Termination - Fixed Breakers



Flat Termination 400A-1600A N/S/H Fr.1-4P

 Bolt length for mounting link(s) on Flat Terminals to be cumulative link(s) thickness + 15 mm.

FRAME 1	A	B	C	D
400 -1600A N	24	50	50	11
400 -1600A S	24	50	65	11
400 -1600A H	30	55	65	9

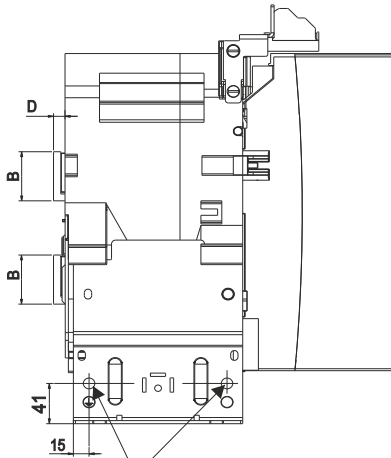

Holes (on both sides) for Earthing connections by M10/Equivalent BS bolt.

M10 bolts to be used for link termination
Tightening torque: 3.0 kgfm

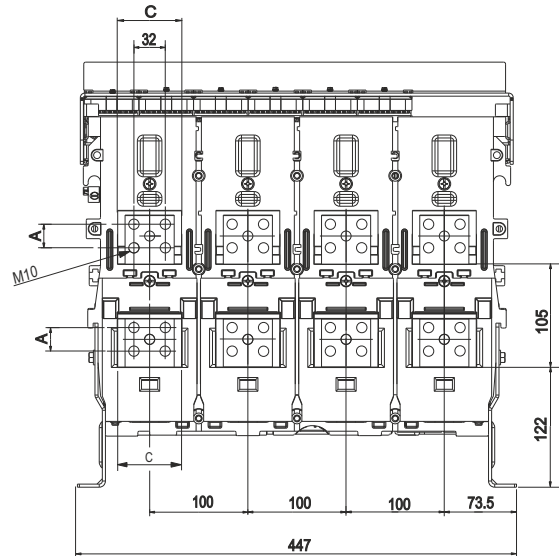

Horizontal Termination 400A-1600A N/S/H Fr.1-4P 2000A N/S/H Fr.1-4P

BREAKER RATING	ADAPTOR CAT NO.
400-2000A N/S	BL609670000
400-2000A H	BL609680000

BREAKER RATING	DIMENSION A
400 - 2000A N/S	74
400 - 2000A H	72

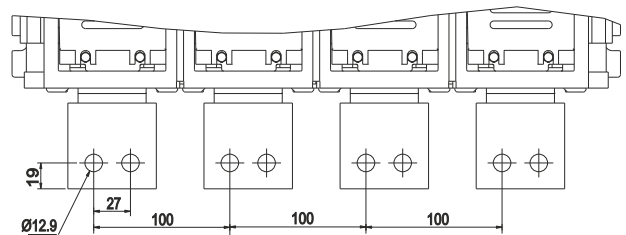
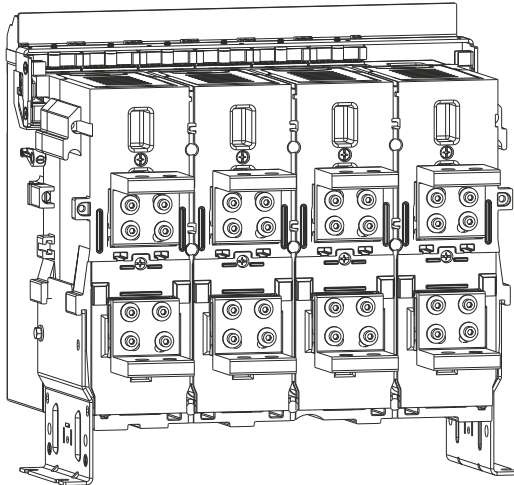
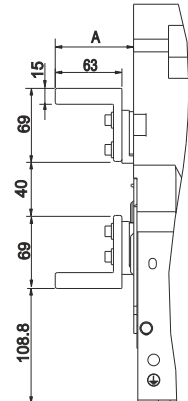

M12 / Equivalent BS bolts to be used for link termination
Tightening torque: 3.2 kgfm

Termination - Fixed Breakers



Vertical Terminals 400A-1600A N/S/H Fr.1-4P & 2000A N/S/H Fr.1-4P

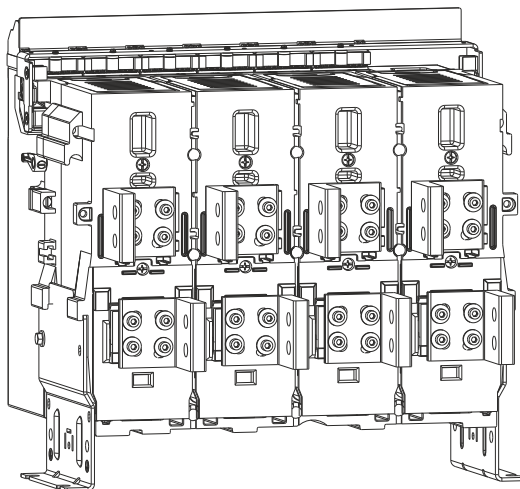

BREAKER RATING	ADAPTOR CAT. No.
400 - 2000A N/S	BL609670000
400-2000A H	BL609680000

BREAKER RATING	DIMENSION A
400 - 2000A N/S	74
400 - 2000A H	72

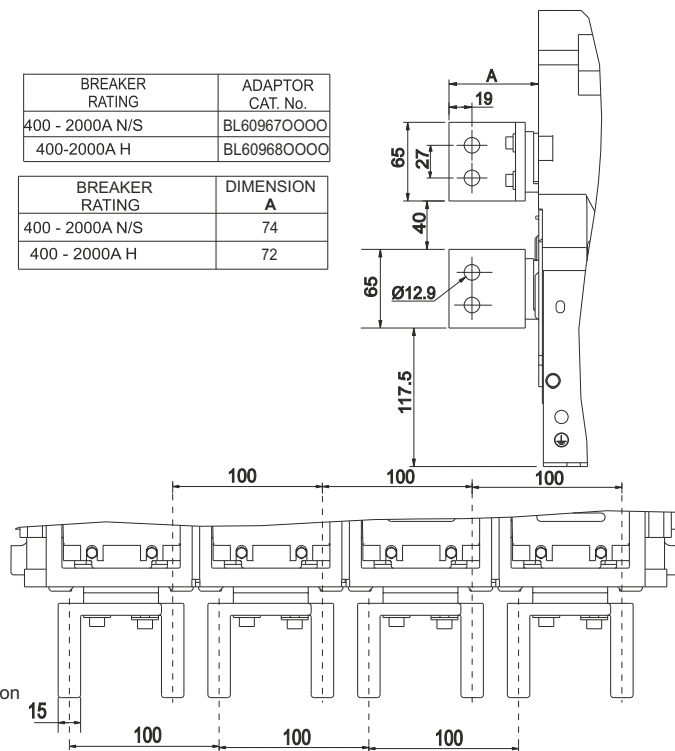

M12 / Equivalent BS bolts to be used for link termination
Tightening torque: 3.2 kgfm

Vertical Terminals 2500A S/H Fr.1-4P (Adaptor-BL609760000)

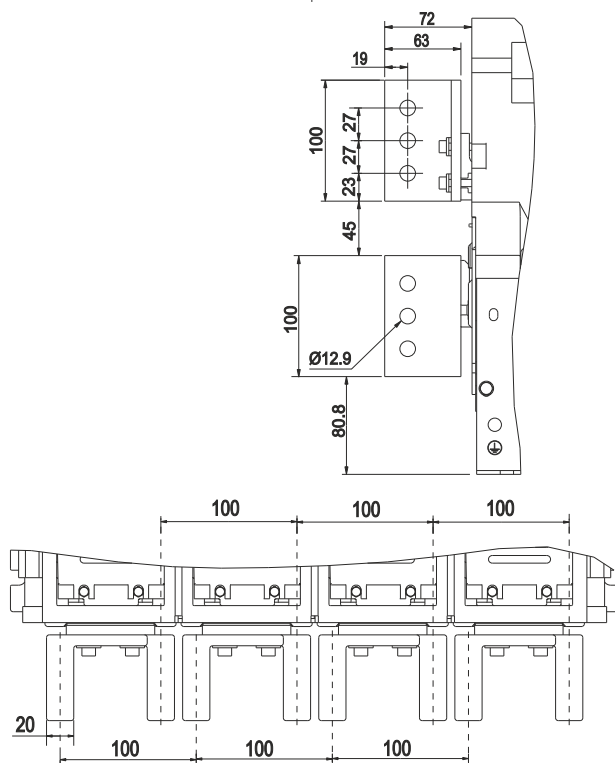
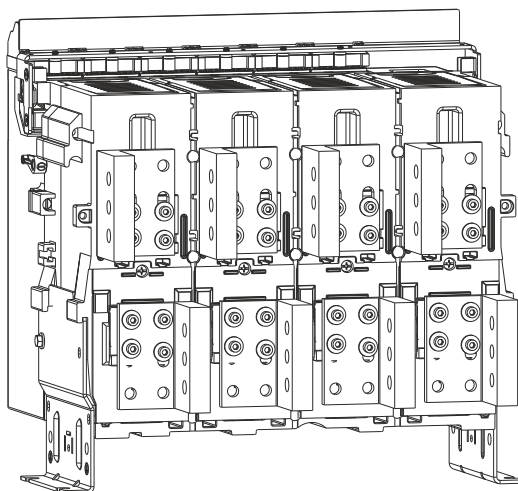

M12 / Equivalent BS bolts to be used for link termination
Tightening torque: 3.2 kgfm

Termination - Fixed Breakers



Flat Termination

400A-1600A N/S/H Fr.2-3P

VERSION	A	B	C
400-1600A N/S	24	24	81.2
400-1600A H	30	30	98.4

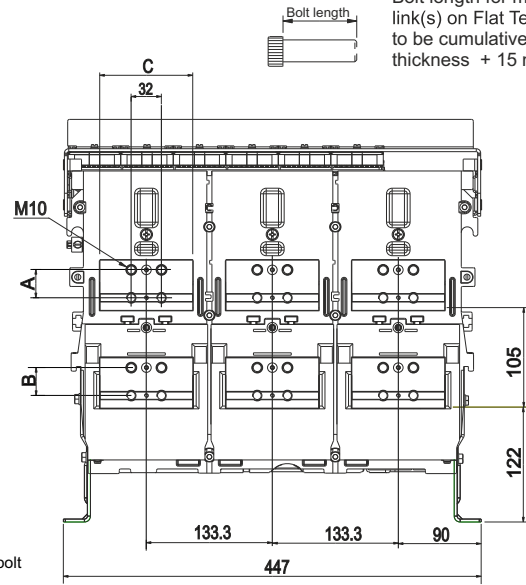
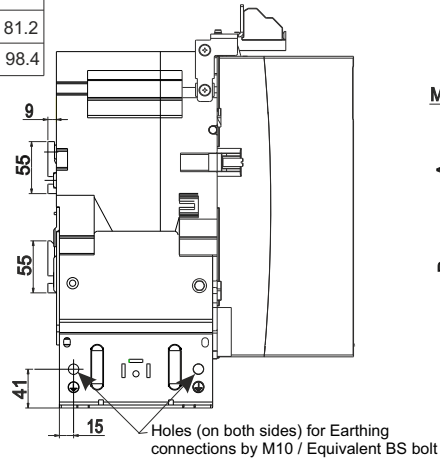

Bolt length for mounting link(s) on Flat Terminals to be cumulative link(s) thickness + 15 mm.

M10 bolts to be used for link termination
Tightening torque: 3.0 kgfm

Horizontal Termination

400A-3200A N/S/H Fr.2-3P

VERSION	ADAPTOR
400-2500A N/S	BL60122O000
3200A N/S	BL60977O000
400-3200A H	BL60977O000

BREAKER RATING	DIMENSION A
400 - 2500A N/S	74
3200A N/S	72
400-3200A H	72

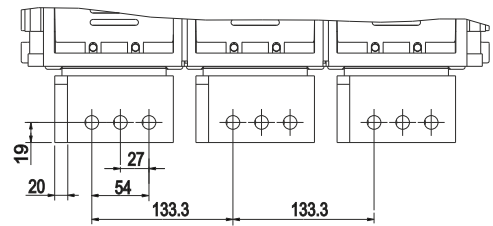
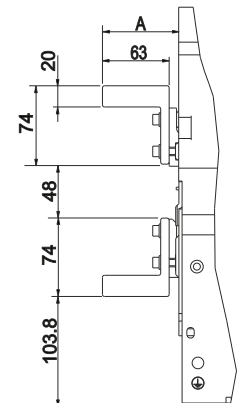
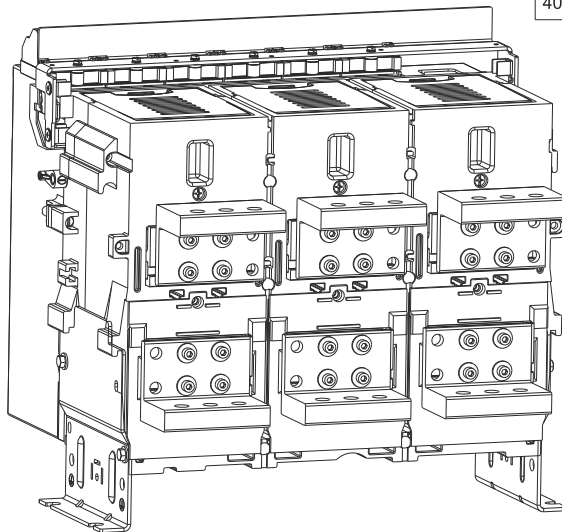

M12 / Equivalent BS bolts to be used for links termination
Tightening torque: 3.2 kgfm

Vertical Termination 400A-4000A N*/N08/N10/S/H Fr.2-3P

VERSION	ADAPTOR
400-2500A N/S	BL601220000
3200-4000A N*/S	BL609770000
400-4000A N08/N10/H	BL609770000

BREAKER RATING	DIMENSION A
400 - 2500A N/S	74
3200-4000A N*/S	72
400-4000A N08/N10/H	72

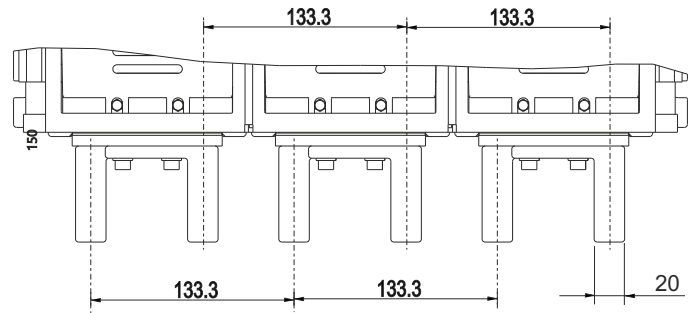
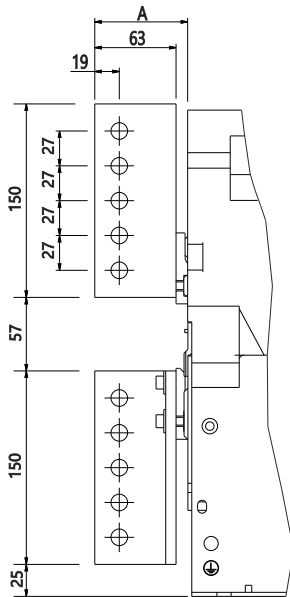
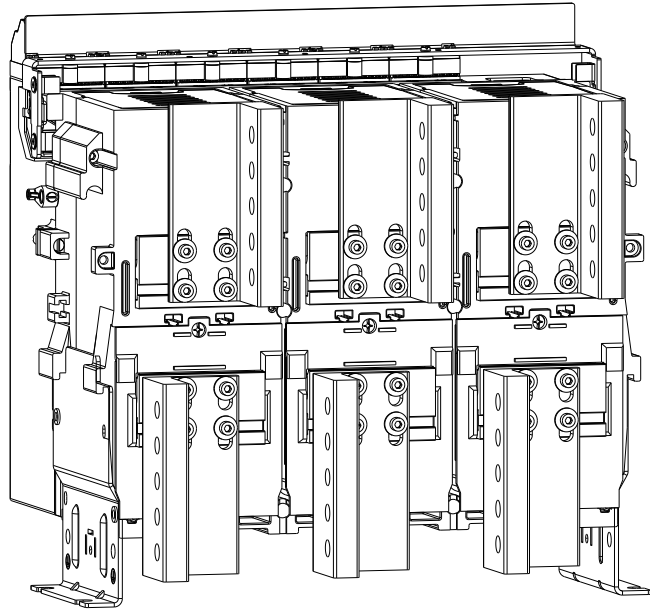

* Available till 3200A

M12 / Equivalent BS bolts to be used for links termination
Tightening torque: 3.2 kgfm

Details of 4P(200% N) on request
All Dimensions in mm

Termination - Fixed Breakers



Flat Termination

400A-1600A N/S/H Fr.2-4P

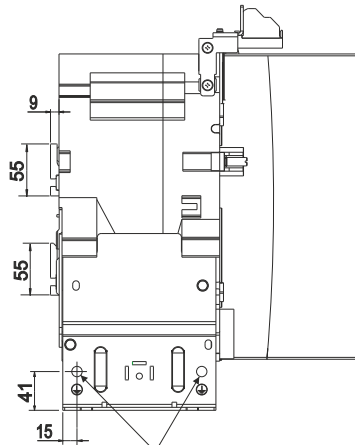

Holes (on both sides) for Earthing connections by M10 / Equivalent BS bolts

M10 bolts to be used for link termination
Tightening torque: 3.0 kgfm

VERSION	A	B	C
400-1600A N/S	24	24	81.2
400-16000A H	30	30	98.4

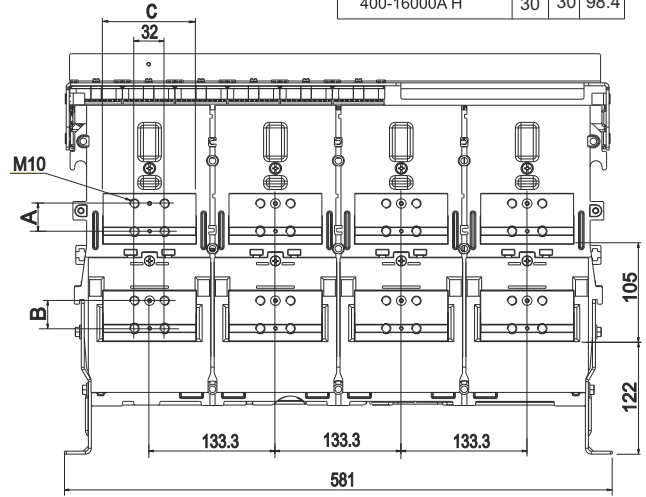

Horizontal Termination

400A-3200A N/S/H Fr.2-4P (100% N)

VERSION	ADAPTOR
400-2500A N/S	BL601220000
3200A N/S	BL609770000
400-3200A H	BL609770000

BREAKER RATING	DIM. A
400 - 2500A N/S	74
3200A N/S	72
400-3200A H	72

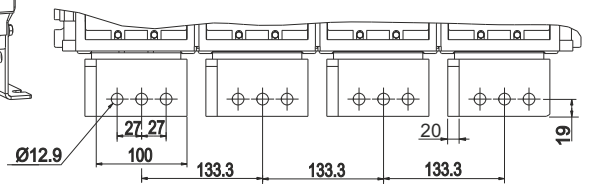
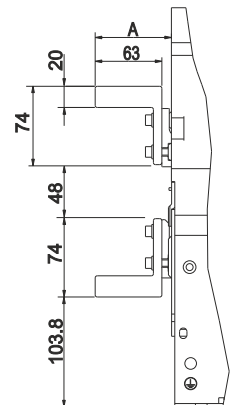
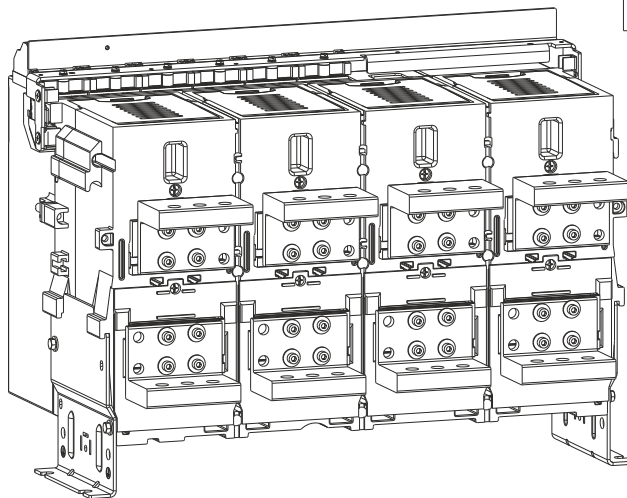

M12 / Equivalent BS bolts to be used for links termination
Tightening torque: 3.2 kgfm

Termination - Fixed Breakers



Vertical Termination 400A-4000A N*/N08/N10/S /H Fr.2-4P (100% N)

VERSION	ADAPTOR
400-2500A N/S	BL601220000
3200-4000A N*/S	BL609770000
400-4000A N08/N10/H	BL603470000

BREAKER RATING	A	B	C	NO OF HOLES
400-2500A N/S	74	100	77.2	3
3200-4000A N*/S	72	100	77.2	3
400-4000A N08/N10/H	72	150	25	5

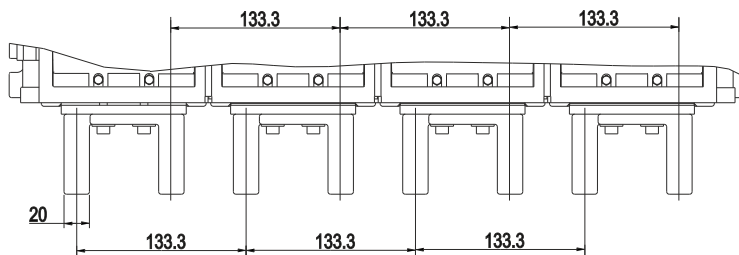
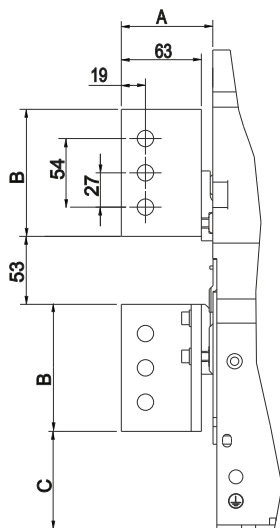
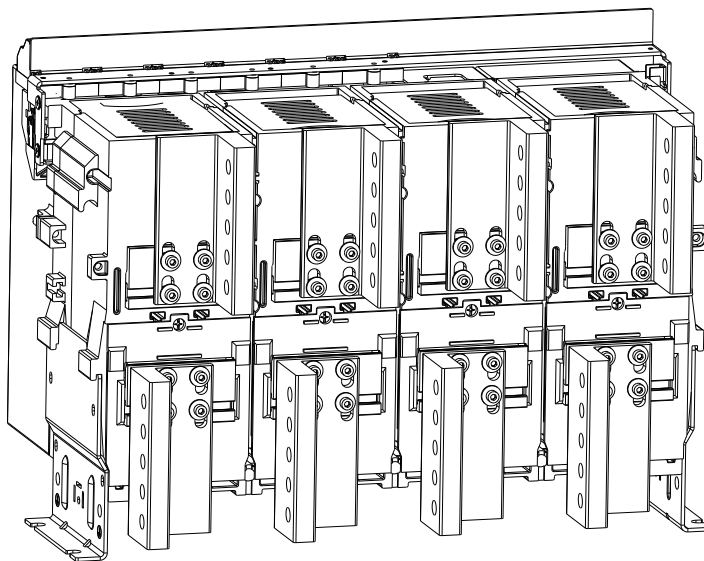

* Available till 3200A

M12 / Equivalent BS bolts to be used for links termination
Tightening torque: 3.2 kgfm

Termination - Fixed Breakers



Flat Termination

400A-1600A H/V Fr.3-3P

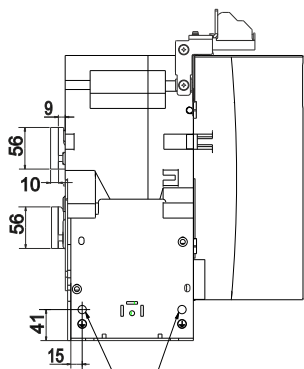

Holes (on both sides) for Earthing connections by M10 / Equivalent BS bolt

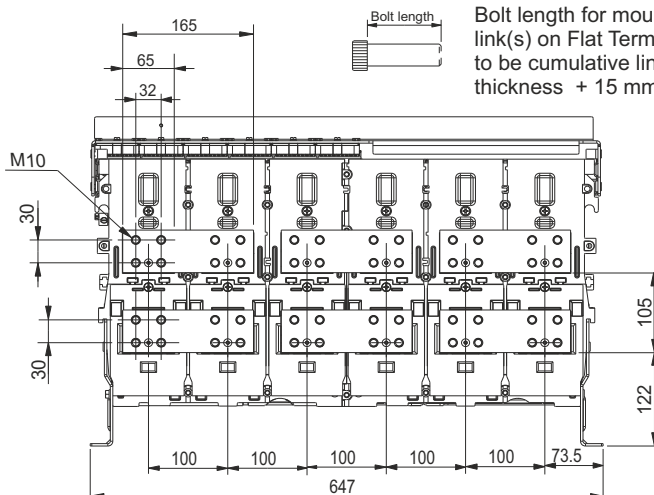

Bolt length for mounting link(s) on Flat Terminals to be cumulative link(s) thickness + 15 mm.

M10 to be used for links termination
Tightening torque: 3.0 kgfm

Horizontal Termination (Bus Coupler Application Only)

400A - 5000A H/V Fr.3-3P

(Adaptor-BL603730000)

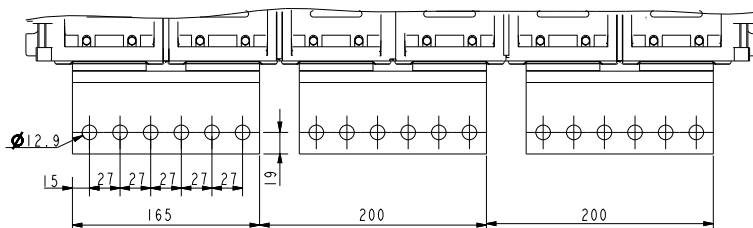
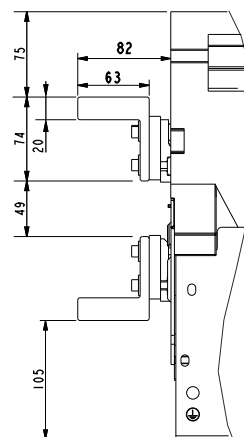
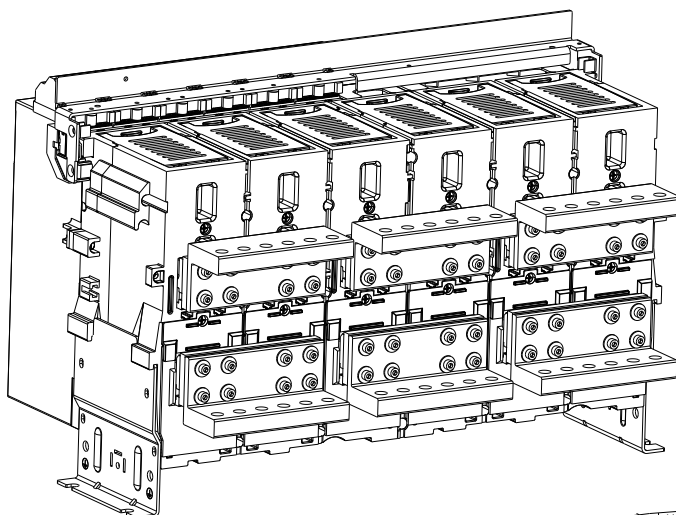

M12 / Equivalent BS bolts to be used for links termination
Tightening torque: 3.2 kgfm

Termination - Fixed Breakers



Vertical Termination 400A-5000A H/V Fr.3-3P

Breaker Rating	Adaptor Cat. No.	Dim. A	Dim. B	No of Holes
400-4000A	BL604180000	125	61	4
5000A	BL603470000	150	36	5

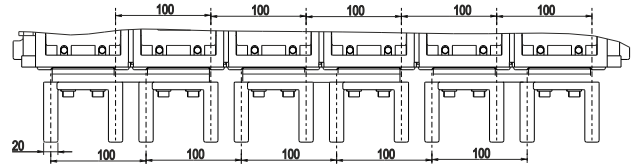
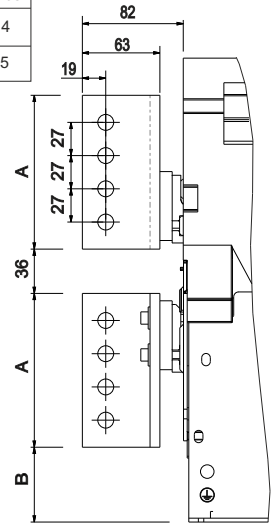
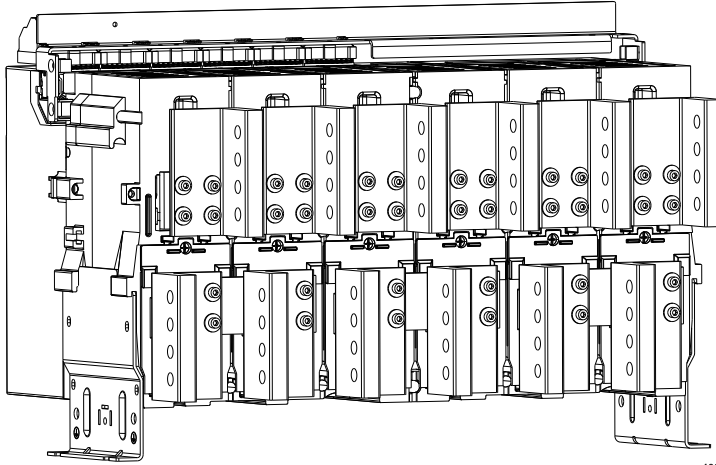

M12 / Equivalent BS bolts to be used for links termination
Tightening torque: 3.2 kgfm

Termination - Fixed Breakers



Flat Termination

400A-1600A H/V Fr.3-4P (100% N)



Bolt length for mounting link(s) on Flat Terminals to be cumulative link(s) thickness + 15 mm.

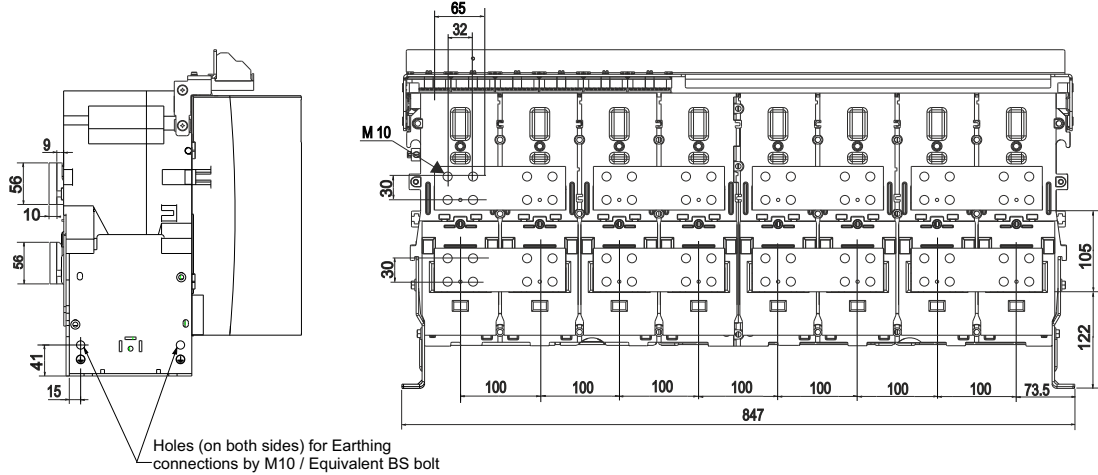

M10 bolts to be used for links termination
Tightening torque: 3.0 kgfm

Horizontal Termination (Bus Coupler Application Only)

400A-5000A H/V Fr.3-4P(100% N)

(Adaptor-BL603730000)

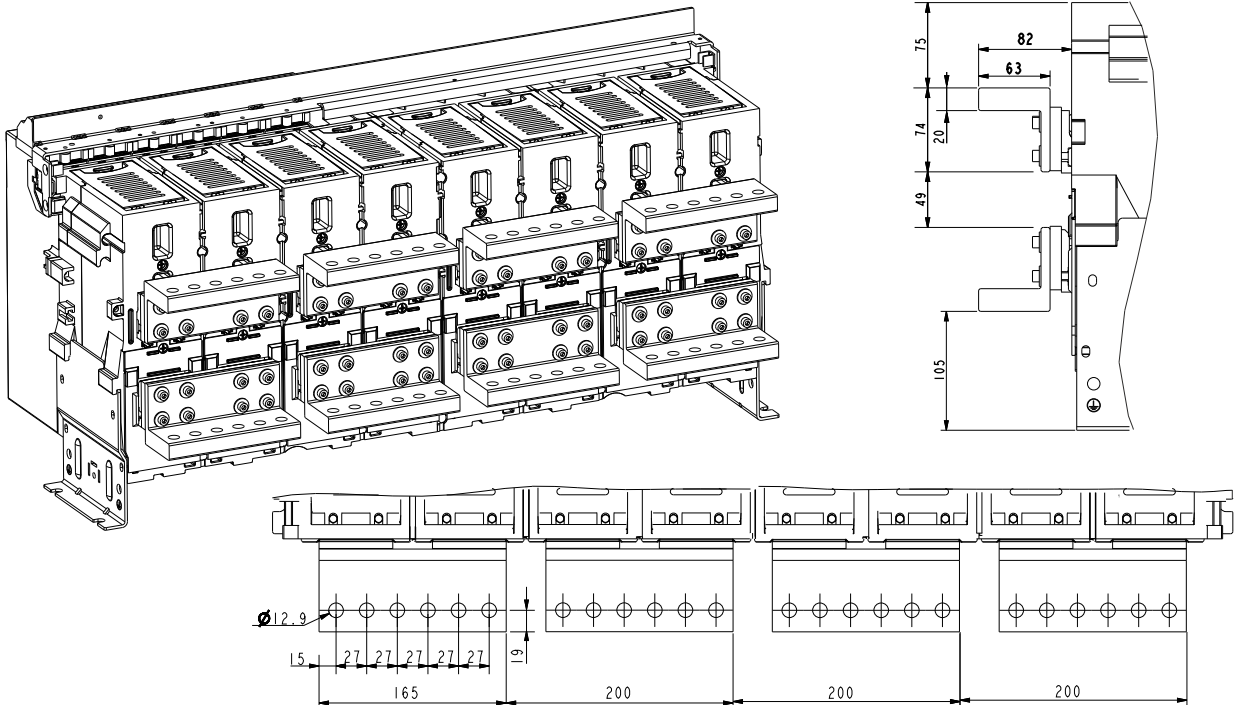

M12 / Equivalent BS bolts to be used for links termination
Tightening torque: 3.2 kgfm

Termination - Fixed Breakers



Vertical Termination 400A-5000A H/V Fr.3-4P (100% N)

Breaker Rating	Adaptor Cat. No.	Dim. A	Dim. B	No of Holes
400-4000A	BL604180000	125	61	4
5000A	BL603470000	150	36	5

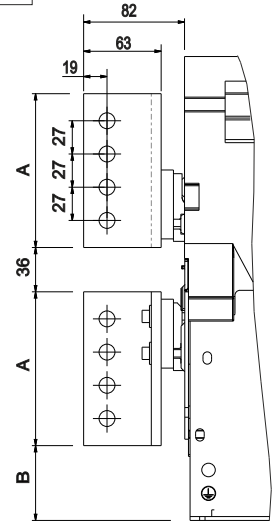
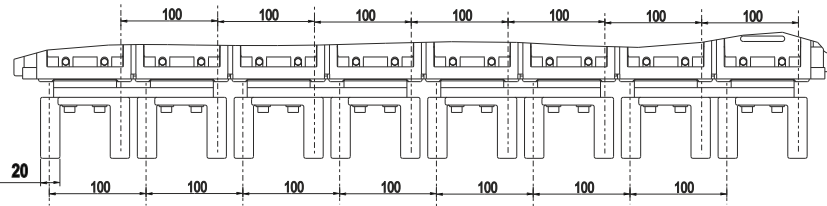
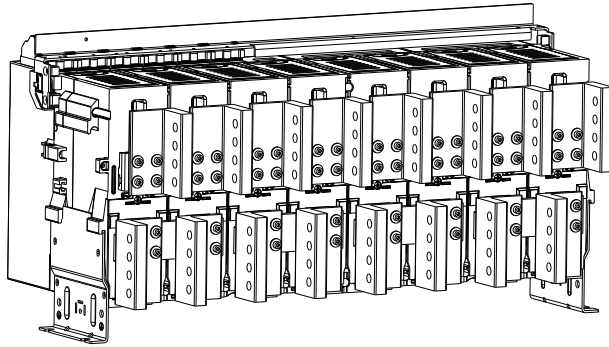

M12 / Equivalent BS bolts to be used for links termination
Tightening torque: 3.2 kgfm

Tightening torque: 3.2 kgfm

Termination - Draw-out Breakers



400A-2000A, N/S/H, Fr.1-3P

Flat Terminals

400A-1600A, N/S/H

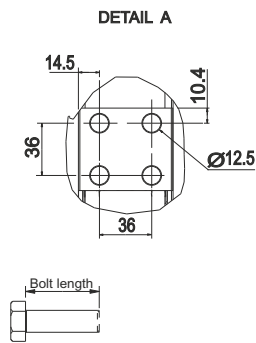

Bolt length for mounting link(s) on Flat Terminals to be cumulative link(s) Thickness + 20 min to 25 max

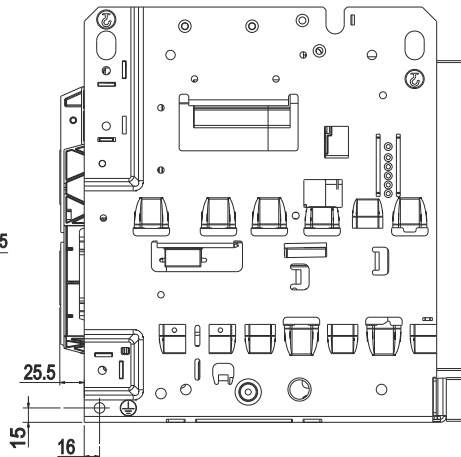

M12 bolts to be used for link termination
Tightening torque: 3.2 kgfm

SEE DETAIL A

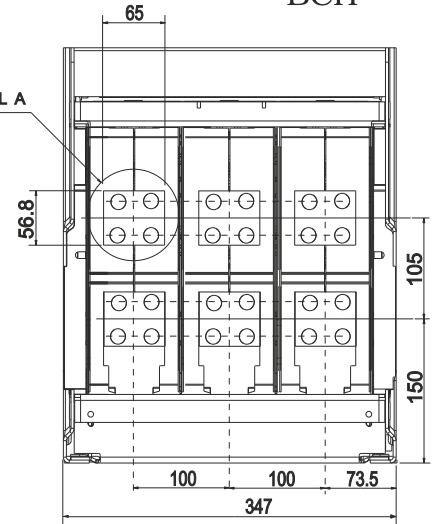

Horizontal Terminals

400A-2000A N/S/H

Adaptor - BLCA609630000

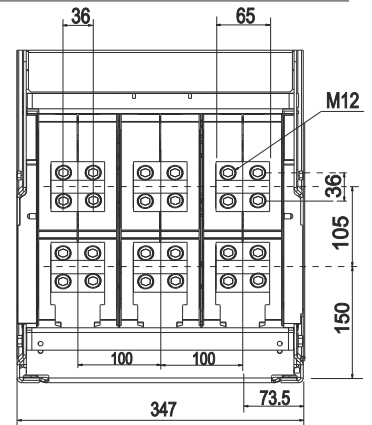
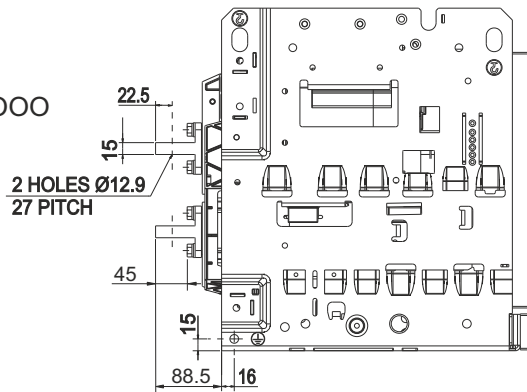

Vertical Terminals

400A - 2000A N/S/H

Adaptor - BLCA609630000

FOR 2500A REFER PAGE 3-30

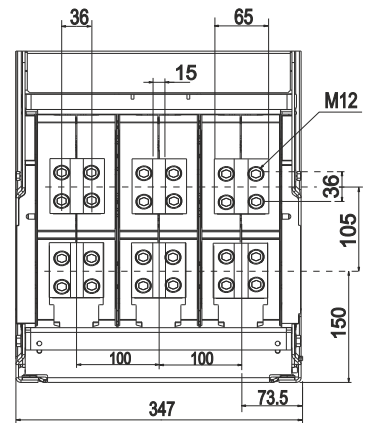
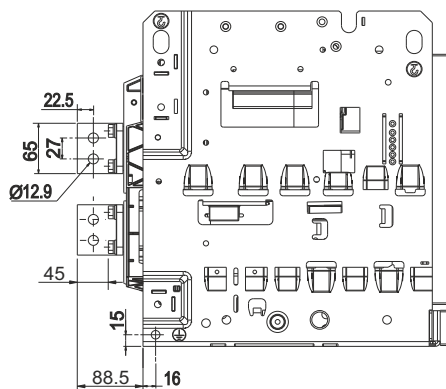

M12 / Equivalent BS bolts to be used for links termination Tightening torque: 3.2 kgfm

All Dimensions in mm

Termination - Draw-out Breakers

2500A, S/H, 3P & 4P (Fr.1)



Vertical Terminals

FOR 2500A - 3P S/H
Adapter - BLCA609640000

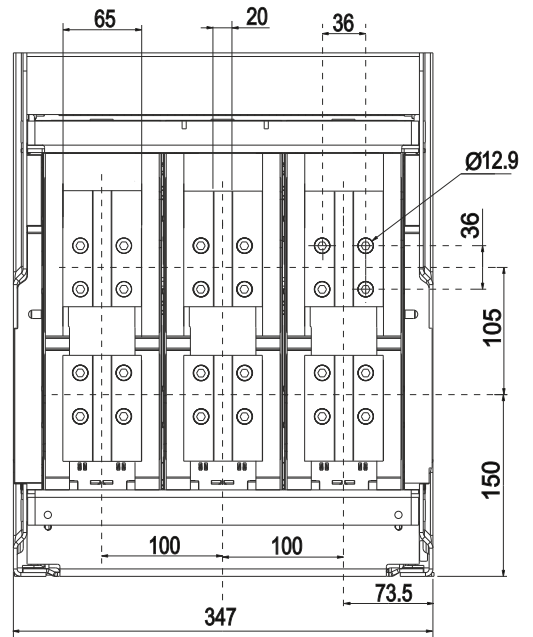
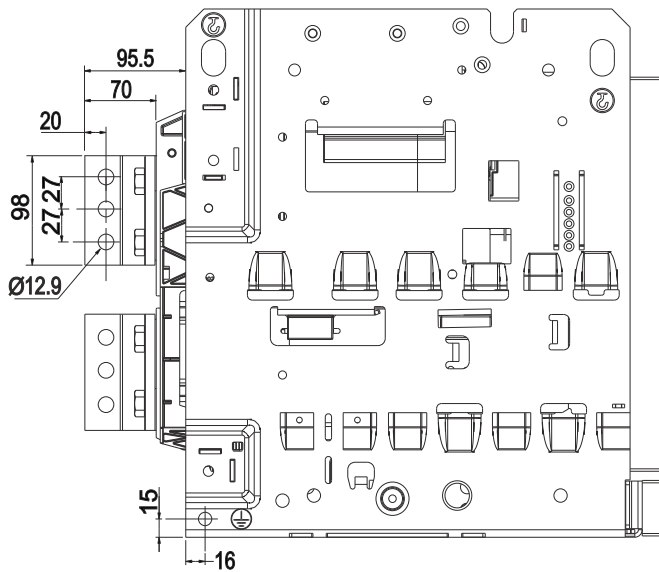

M12 / Equivalent BS bolts to be used for links termination
Tightening torque: 3.2 kgfm

Vertical Terminals

FOR 2500A - 4P S/H
Adapter - BLCA609640000

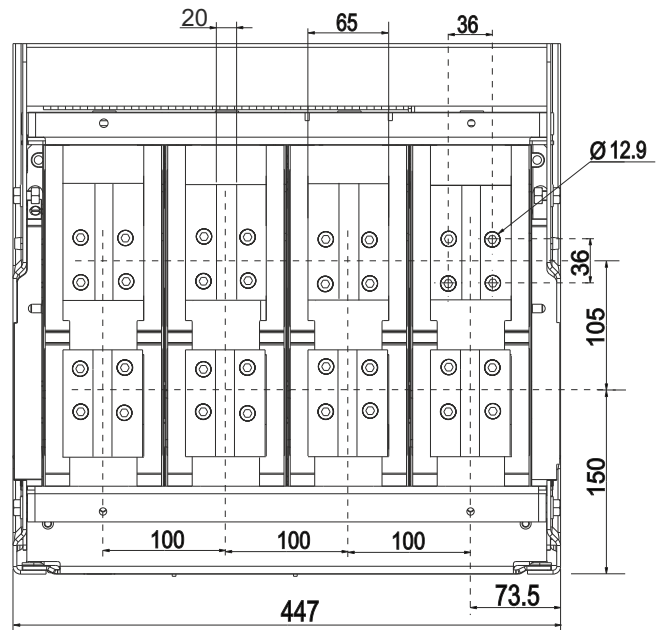
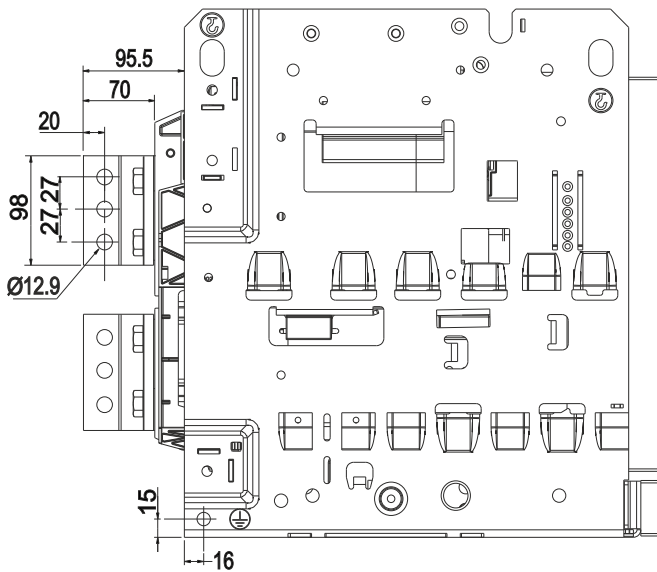

M12 / Equivalent BS bolts to be used for links termination
Tightening torque: 3.2 kgfm

All Dimensions in mm

Termination - Draw-out Breakers

400A-2000A, N/S/H, Fr. 1-4P (100%N)

Flat Terminals

400A-1600A, N/S/H

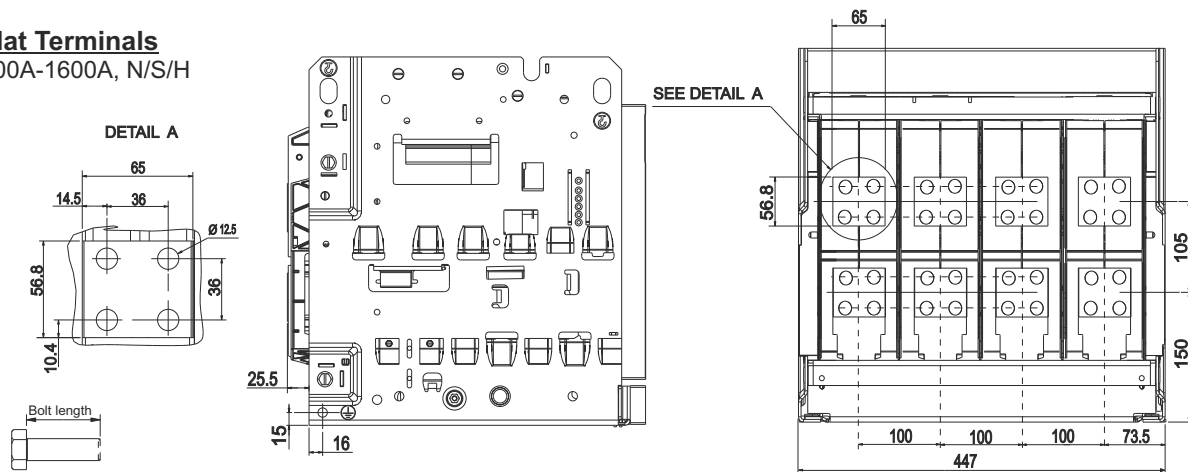

Bolt length for mounting link(s) on Flat Terminals to be cumulative link(s) thickness +20 min to 25 max.

M12 bolts to be used for link termination
Tightening torque: 3.2 kgfm

Horizontal Terminals

400A - 2000A N/S/H

Adaptor - BLCA609630000

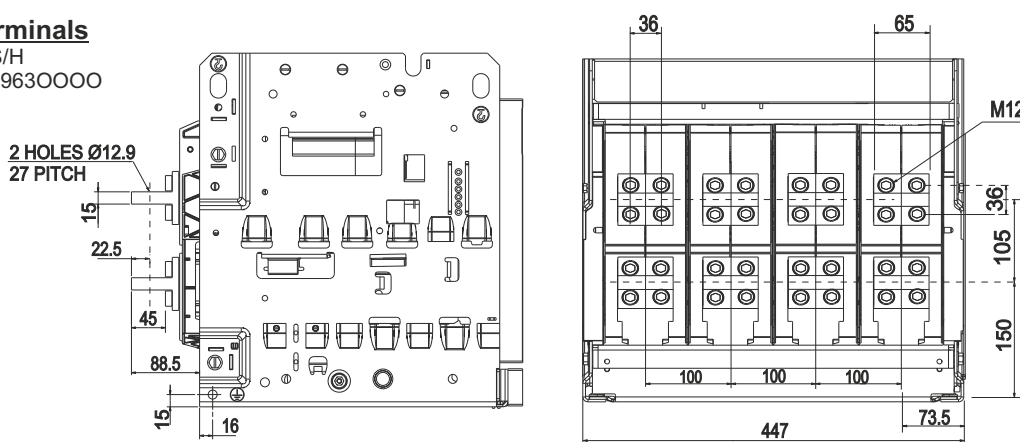

Vertical Terminals

400A - 2000A N/S/H

Adaptor - BLCA609630000

For 2500A REFER PAGE 3-30

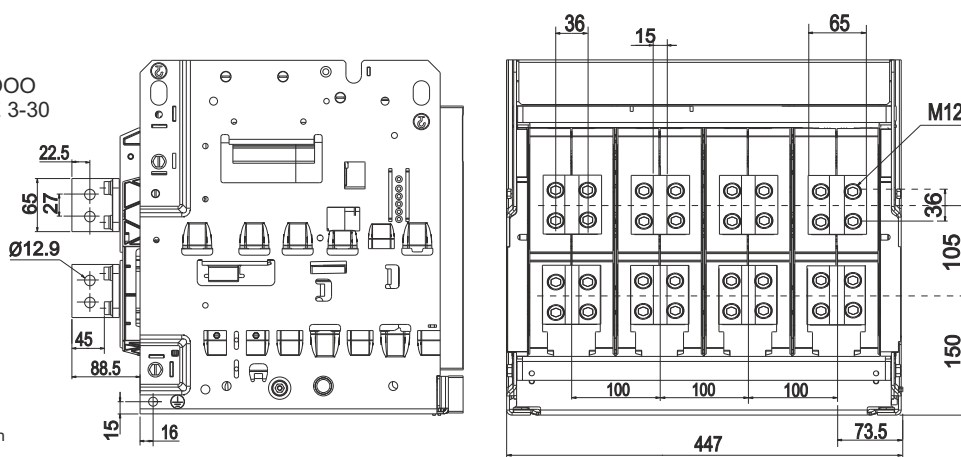

M12 / Equivalent BS bolts to be used for links termination
Tightening torque: 3.2 kgfm

All Dimensions in mm

Termination - Draw-out Breakers

400A-3200A, N/S/H Fr.2-3P

Flat Terminals

400A-1600A, N/S/H

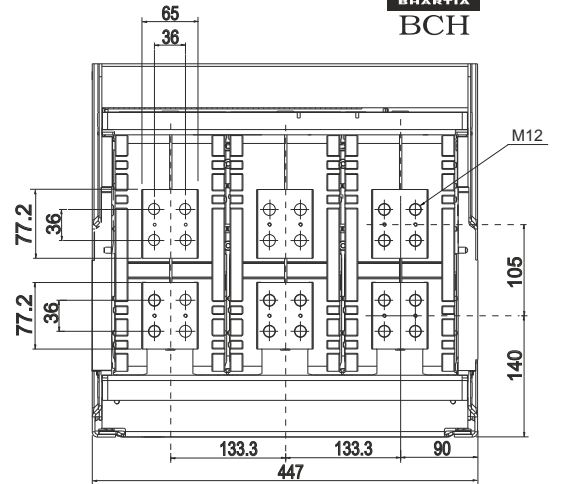
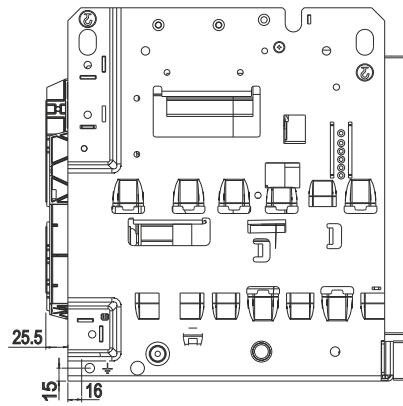

Bolt length for mounting link(s) on Flat Terminals to be cumulative link(s) thickness+20 min to 25 max

M12 bolts to be used for link termination
Tightening torque: 3.2 kgfm

Horizontal Terminals

400A-3200A, N/S/H

Adaptor - BLCA60964O000

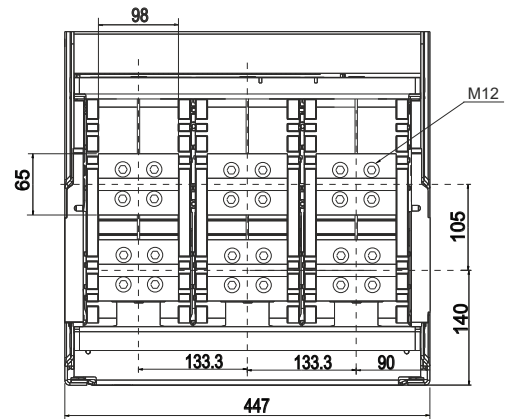
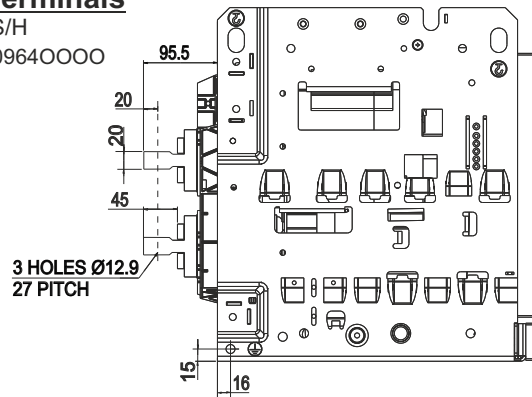

Vertical Terminals

400A-3200A, N/S/H

Adaptor - BLCA60964O000

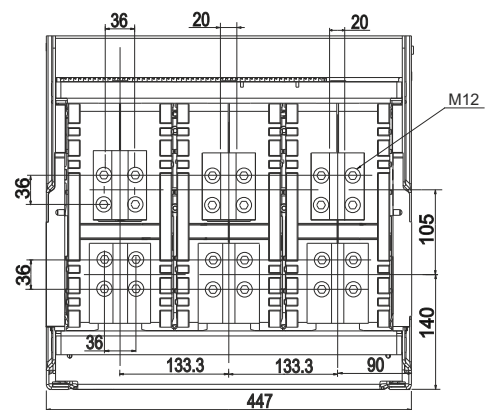
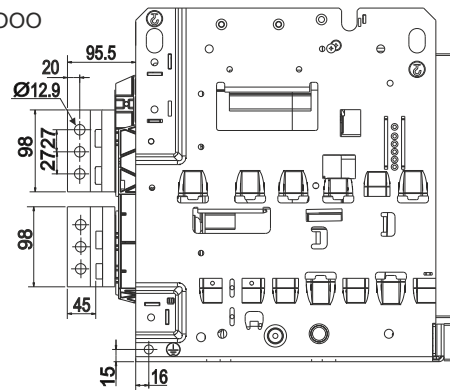

M12 / Equivalent BS bolts to be used for links termination
Tightening torque: 3.2 kgfm

Termination - Draw-out Breakers

4000A, S/H, Fr.2-3P



Vertical Terminals

4000A, S/H

Adaptor - BL604200000

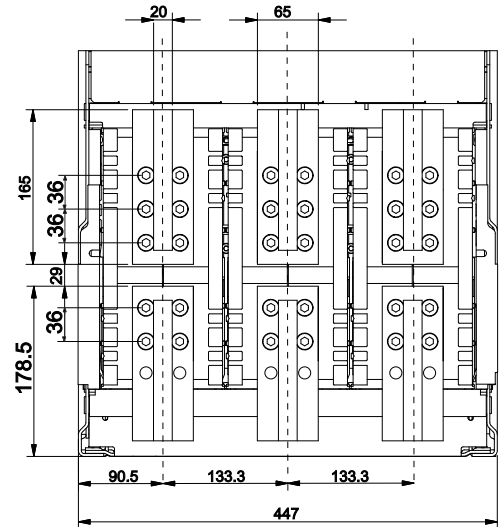
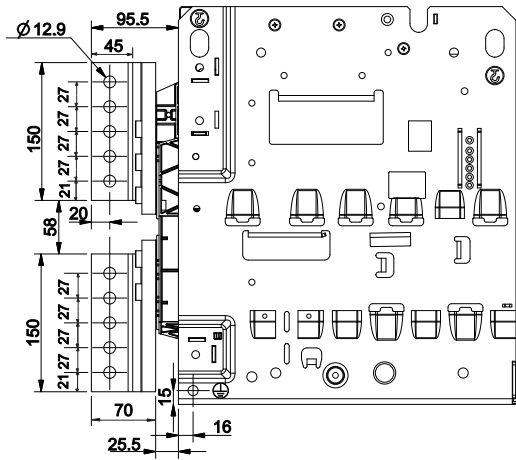

Top Horizontal & Bottom Vertical Terminal

4000A, S/H

Adaptor - Horizontal: BL603160000

Vertical: BL604200000

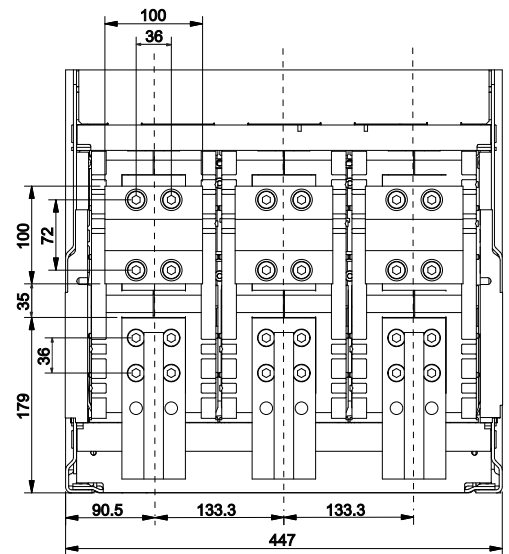
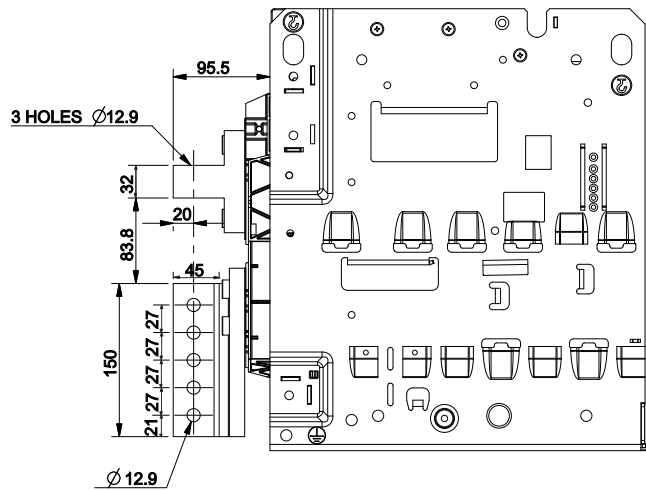

Horizontal Adaptor: BL603160000

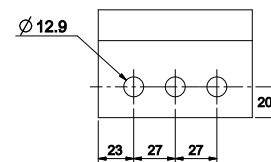

M12 / Equivalent BS bolts to be used for links termination.
Tightening torque: 3.2 kgfm

Termination - Draw-out Breakers

400A-3200A, N/S/H, Fr.2-4P (100% N)



Flat Terminals

400A-1600A, N/S/H

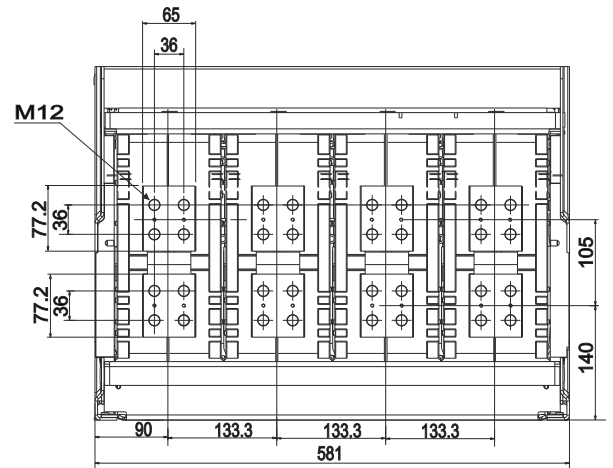
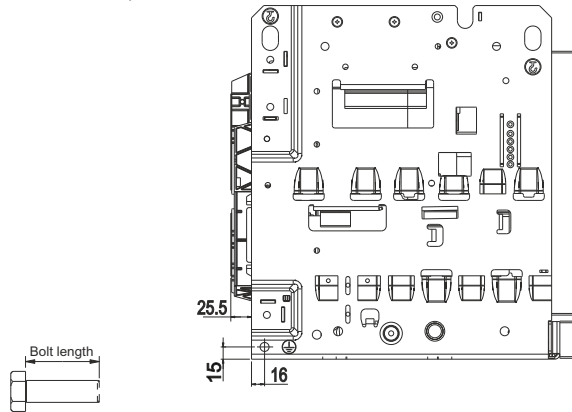

Bolt length for mounting link(s) on Flat Terminals to be cumulative link(s) thickness+20 min to 25 max

M12 bolts to be used for link termination
Tightening torque: 3.2 kgfm

Horizontal Terminals

400A-3200A, N/S/H

Adaptor - BLCA609640000

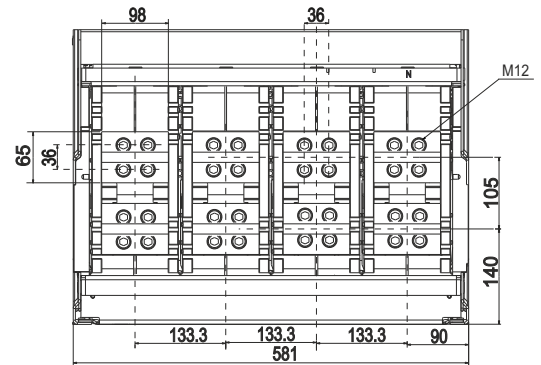
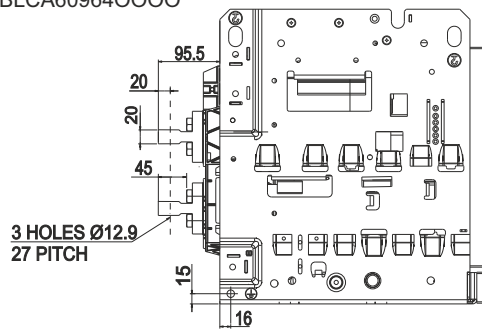

Vertical Terminals

400A-3200A N/S/H

Adaptor - BLCA609640000

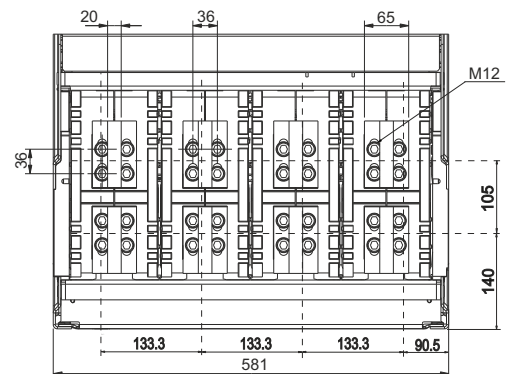
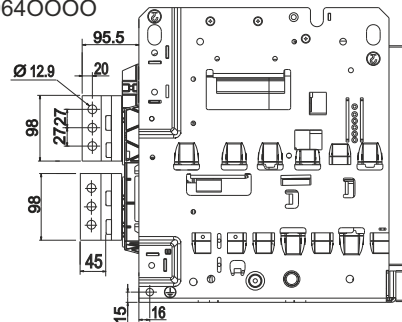

M12 / Equivalent BS bolts to be used for links termination.
Tightening torque: 3.2 kgfm

Termination - Draw-out Breakers

4000A, S/H, Fr.2-4P (100% N)



Vertical Terminals

4000A, S/H
Adaptor - BL604200000

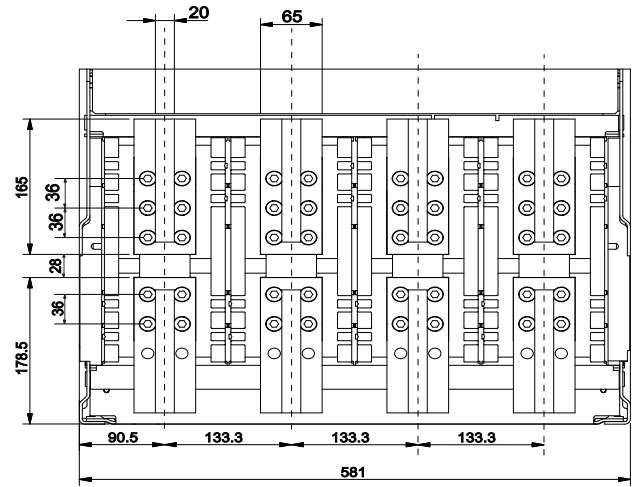
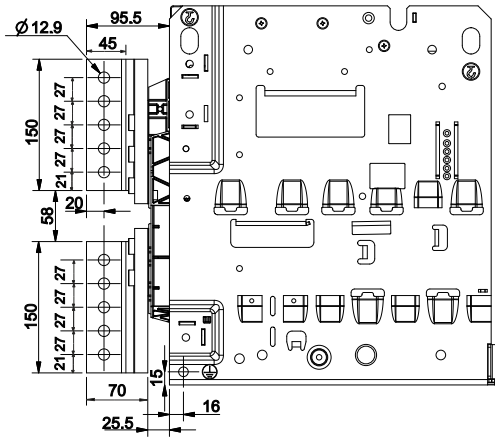

Top Horizontal & Bottom Vertical Terminal

4000A, S/H
Adaptor - Horizontal: BL603160000
Vertical: BL604200000

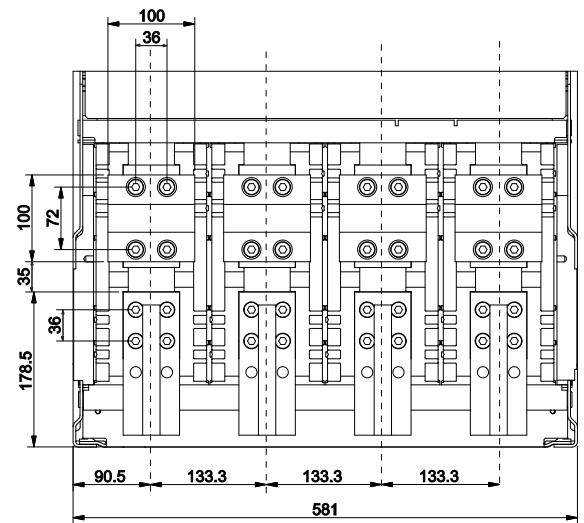
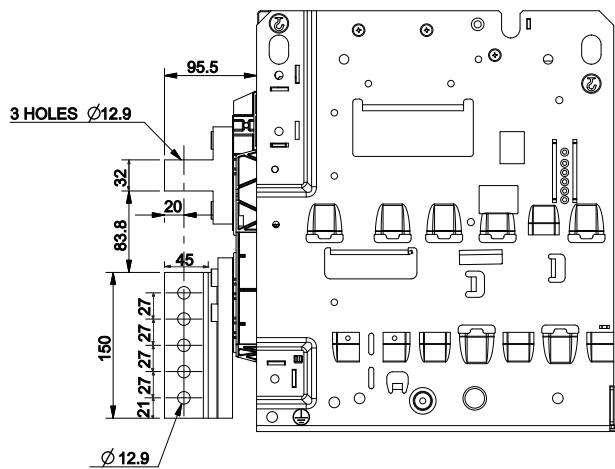

Horizontal Adaptor: BL603160000

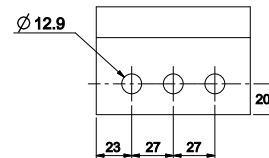

M12 / Equivalent BS bolts to be used for links termination.
Tightening torque: 3.2 kgfm

Termination - Draw-out Breakers

400A-4000A H/V Fr.3-3P, 5000A H/V Fr.3-3P
& 6300A, H/V Fr.3-3P



Flat Terminals

400A-1600A H/V

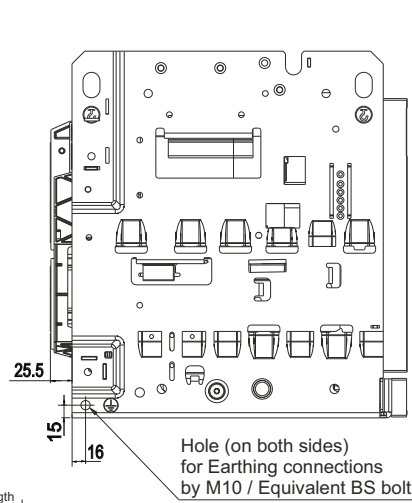

Bolt length for mounting link(s) on Flat Terminal to be cumulative link(s) thickness + 20 min to 25 max

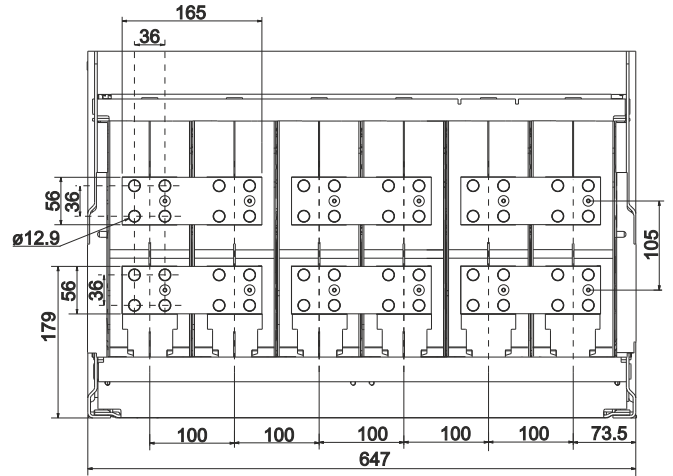

M12 bolts to be used for link termination
Tightening torque: 3.2 kgfm

Horizontal Terminals (Bus Coupler Application Only)

400A-4000A N08/H/V

Adaptor - BL600730000

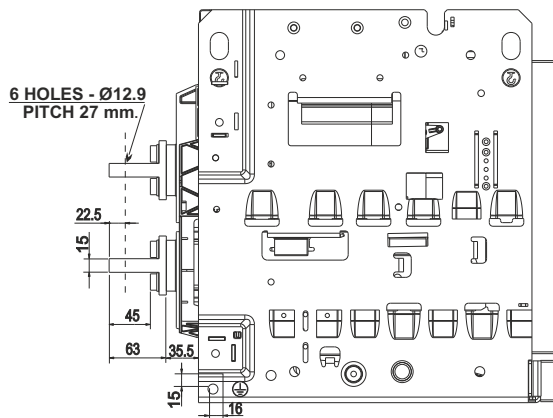

M12 / Equivalent BS bolts to be used for links termination.
Tightening torque: 3.2 kgfm

All Dimensions in mm

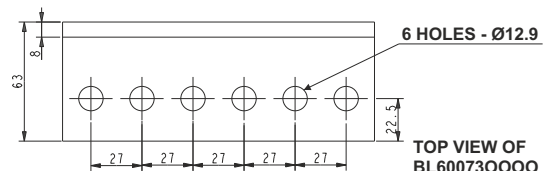
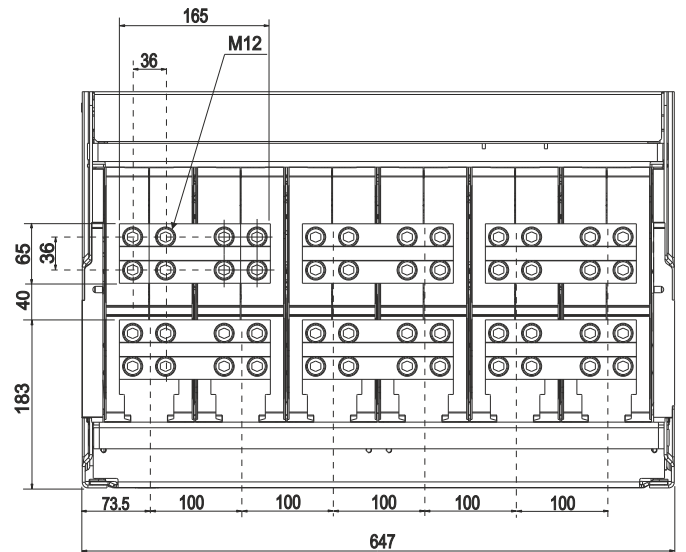

Termination - Draw-out Breakers

400A-4000A H/V Fr.3-3P, 5000A H/V Fr.3-3P
& 6300A H/V Fr.3-3P

Vertical Terminals

400A-4000A H/V
Adaptor - BL601280000

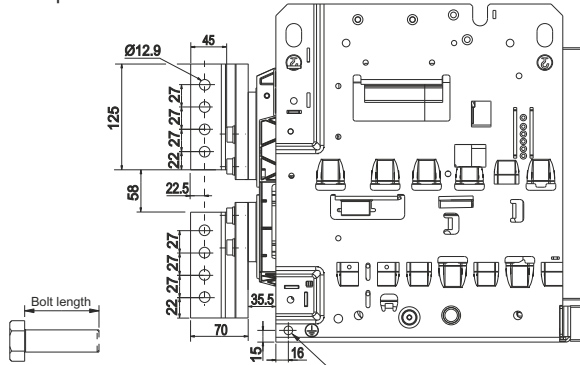

Bolt length for mounting link(s) on Flat Terminalsto be cumulative link(s) thickness+20 min to 25 max

Hole (on both sides) for Earthing connections by M10 / Equivalent BS bolt

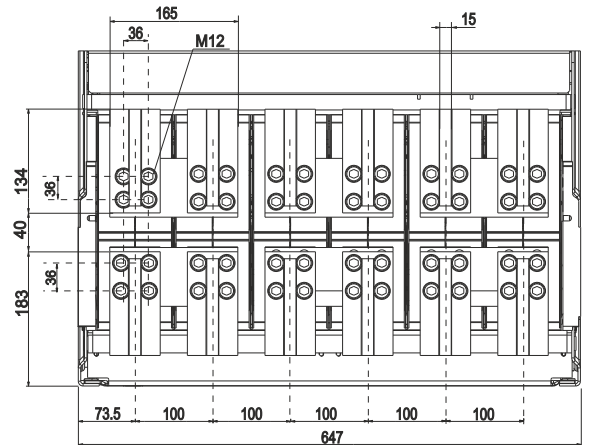

Vertical Terminals

5000A H/V
Adaptor - BL600670000

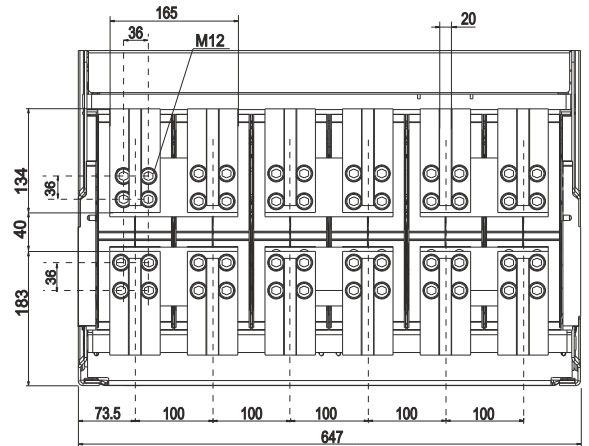
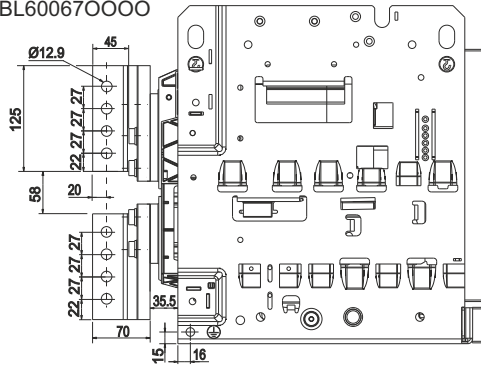

Vertical Terminals

6300A H/V
Adaptor - BL609650000

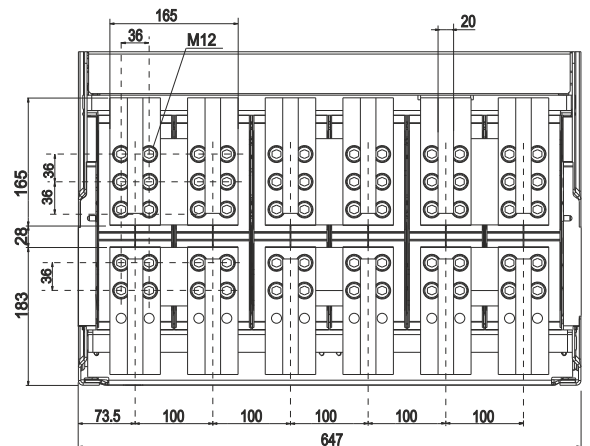
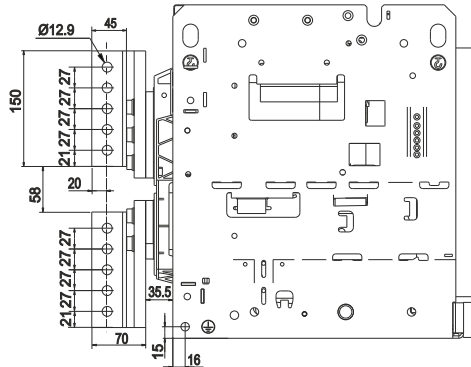

M12 / Equivalent BS bolts to be used for links termination.
Tightening torque: 3.2 kgfm

Termination - Draw-out Breakers

400A-4000A H/V Fr.3-4P (100% N), 5000A H/V Fr.3-4P (100% N)
& 6300A H/V Fr.3-4P (100% N)

Flat Terminals

400A-1600A H/V

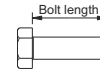

Bolt length for mounting link(s) on
Flat Terminals to be cumulative link(s)
thickness+20 min to 25 max

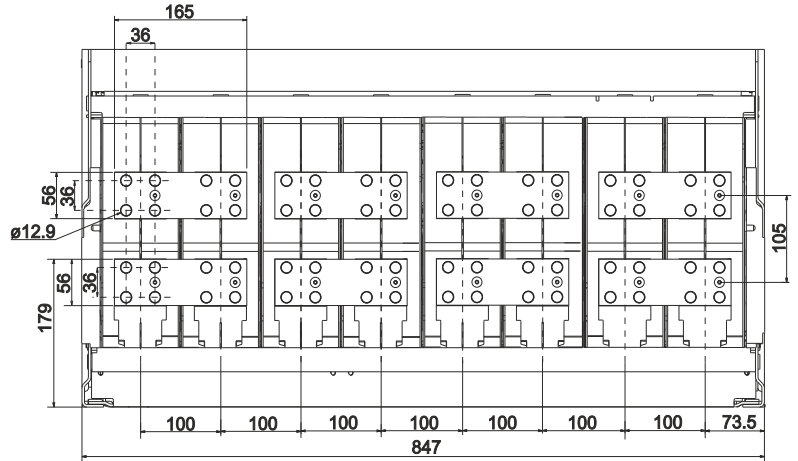
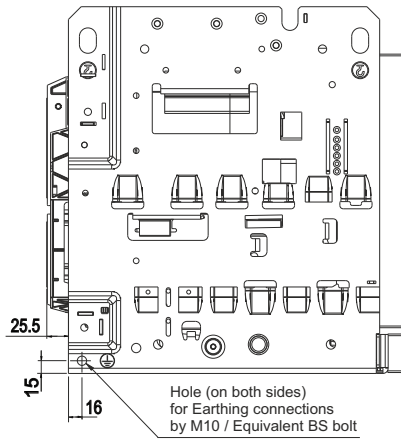

Horizontal Terminals (Bus Coupler Application Only)

400A-4000A

Adaptor - BL600730000

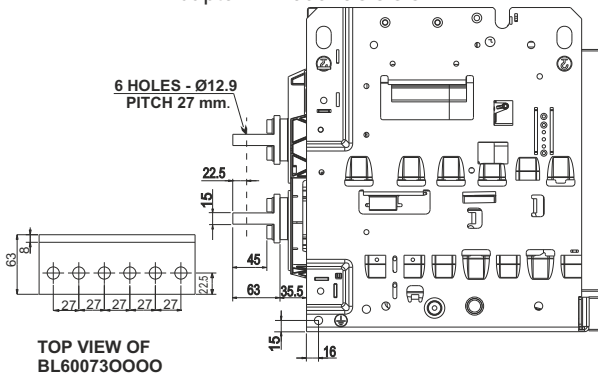

TOP VIEW OF
BL600730000

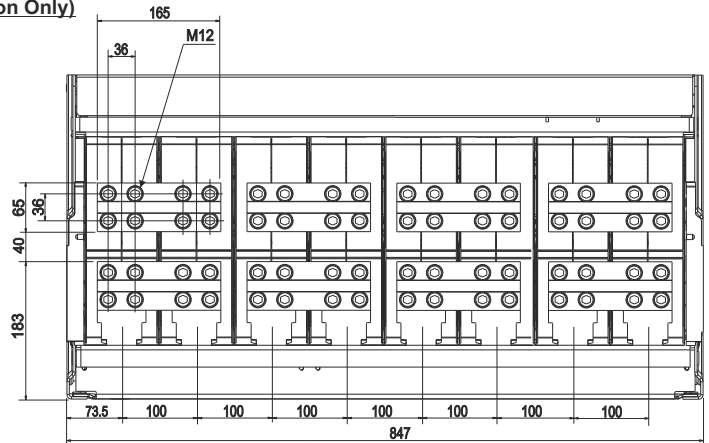

Horizontal Terminals (Bus Coupler Application Only)

5000A

Adaptor - BL609660000

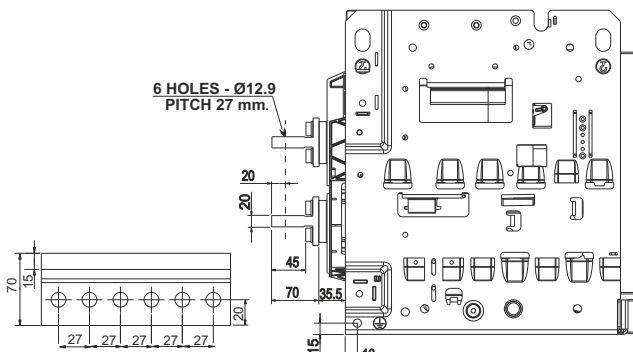

TOP VIEW OF
BL609660000

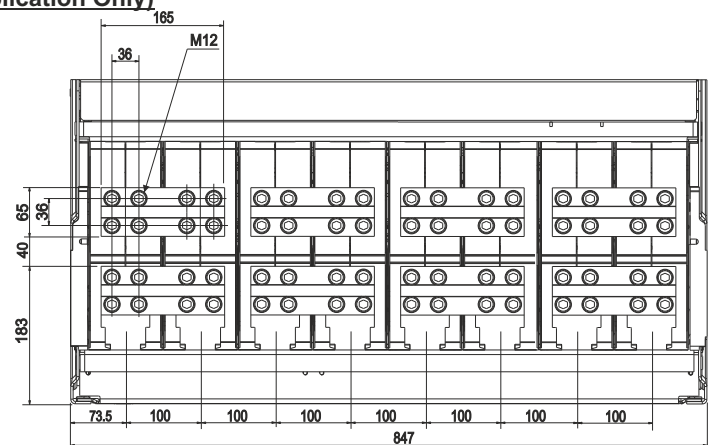

M12 bolts to be used for link termination
Tightening torque: 3.2 kgfm

All Dimensions in mm

Termination - Draw-out Breakers

400A-4000A H/V Fr.3-4P (100% N), 5000A H/V Fr.3-4P (100% N)
& 6300A H/V Fr.3-4P (100% N)

Vertical Terminals

400A-4000A H/V
Adaptor - BL601280000

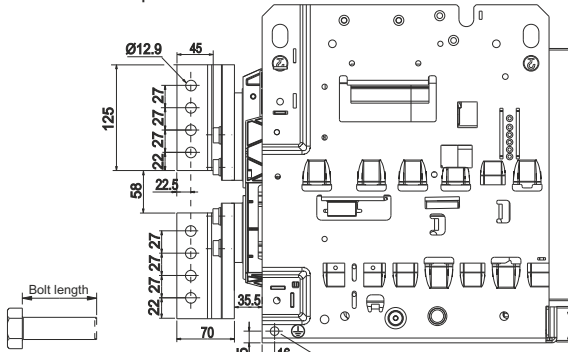

Bolt length for mounting link(s) on Flat Terminals to be cumulative link(s) thickness+20 min to 25 max
Hole (on both sides) for Earthing connections by M10 / Equivalent BS bolt

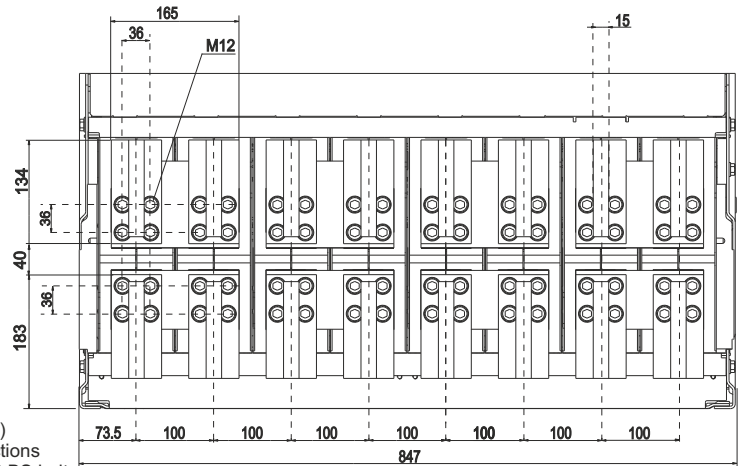

Vertical Terminals

5000A H/V
Adaptor - BL600670000

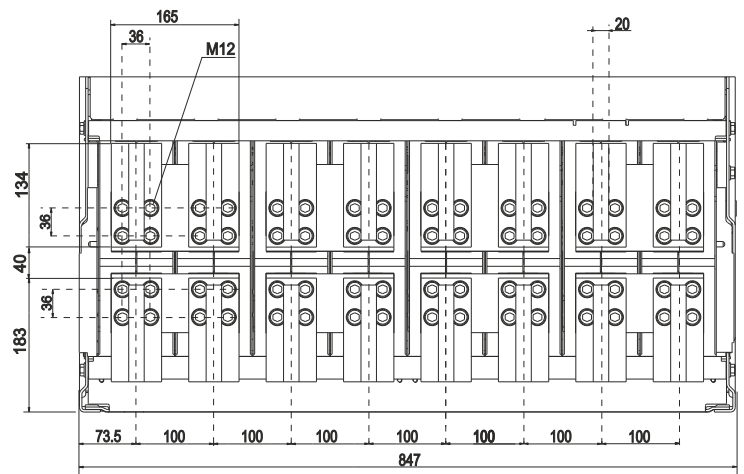
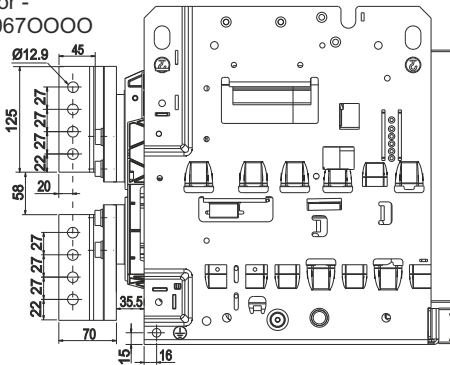

Vertical Terminals

6300A H/V
Adaptor - BL609650000

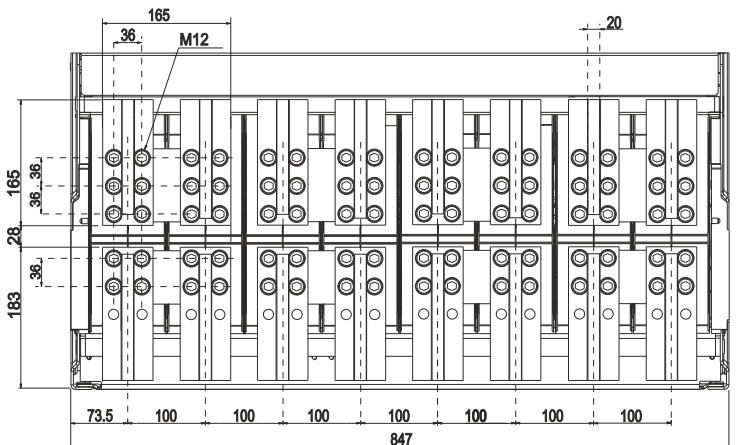
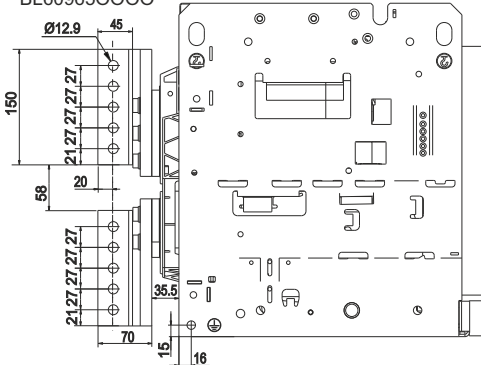

M12 / Equivalent BS bolts to be used for links termination.
Tightening torque: 3.2 kgfm

Termination - Draw-out Breakers

400A-4000A H/V Fr.3-4P (50% N) & 5000A H/V Fr.3-4P (50% N)

Flat Terminals

400A-1600A H/V



*For Phase poles R, Y, B only
Not applicable for Neutral pole

Bolt length for mounting link(s) on
Flat Terminals to be cumulative link(s)
thickness+20 min to 25 max

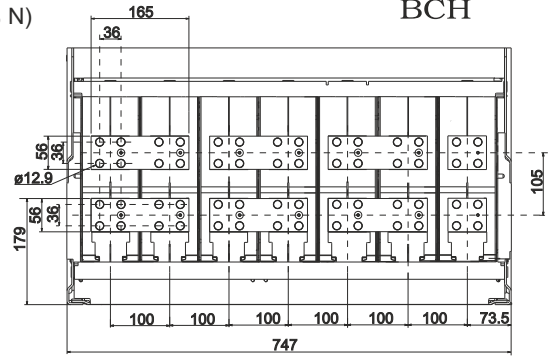
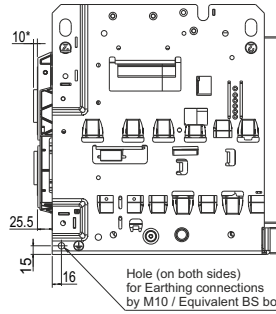

Horizontal Terminals (For Bus Coupler application only)

400A-4000A H/V
Adaptor - BL600730000

5000A H/V
Adaptor - BL609660000

6 HOLES - Ø12.9
PITCH 27 mm.

POLES	A
Phase: R, Y, B	35.5
Neutral: N	25.5

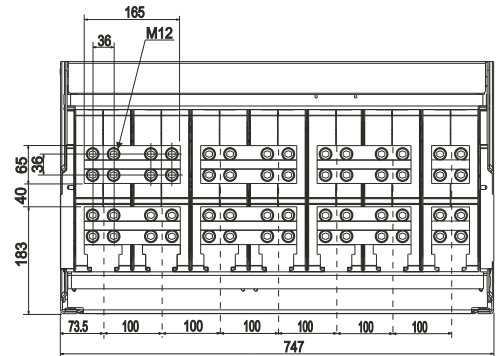
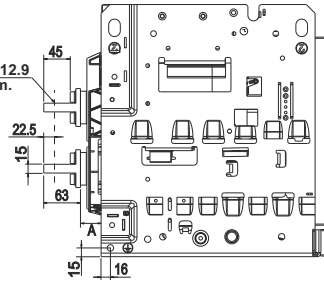

Vertical Terminals

400A-4000A H/V
Adaptor - BL601280000

POLES	A
Phase: R, Y, B	35.5
Neutral: N	25.5

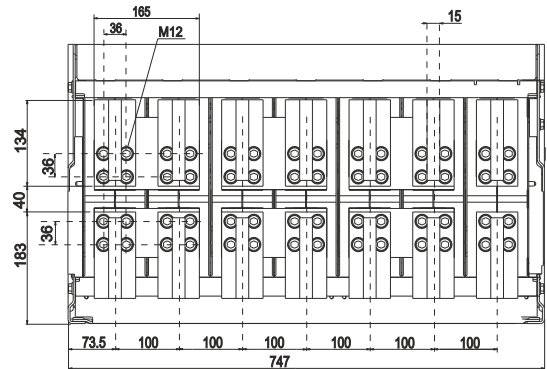
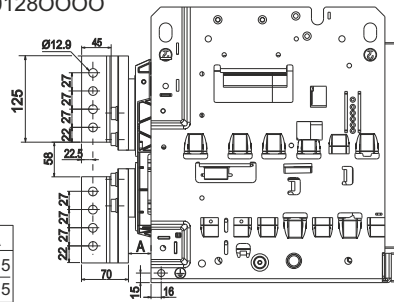

Vertical Terminals

5000A H/V
Adaptor - BL600670000

POLES	A
Phase: R, Y, B	35.5
Neutral: N	25.5

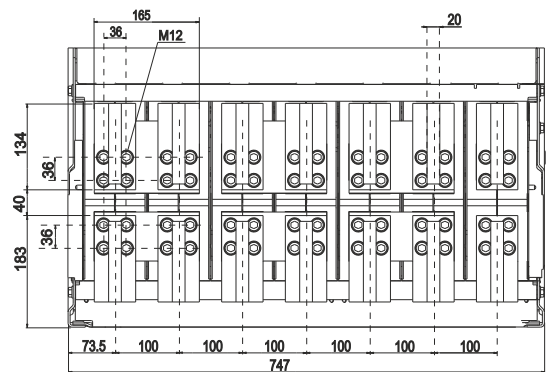
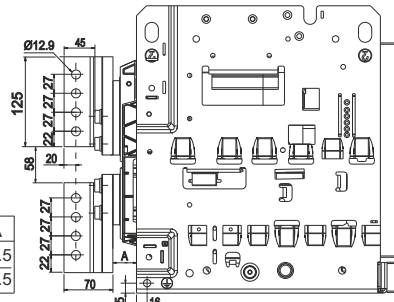

M12/Equivalent BS bolts to be used for link termination
Tightening torque: 3.2 kgfm

Termination - Fixed Breakers



Flat Termination

400A-800A N/S/H Fr.1-4P (200% N)

FRAME 1	A	B	C	D
400 - 800A N	24	50	50	11
400 - 800A S	24	50	65	11
400 - 800A H	30	55	65	9

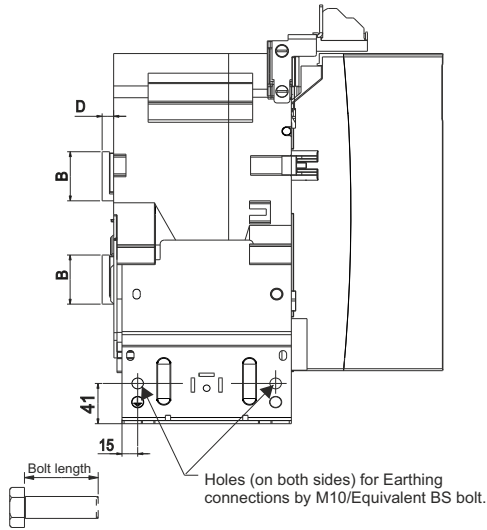

Bolt length for mounting link(s) on Flat Terminals to be cumulative link(s) thickness + 15 mm.

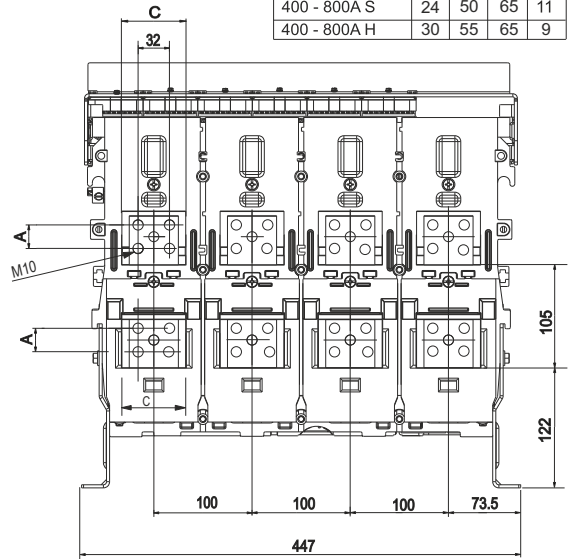

M10 bolts to be used for link termination
Tightening torque: 3.0 kgfm

Horizontal Termination

400A-1000A N/S Fr.1-4P (200% N)
400A-1000A H Fr.1-4P (200% N)

BREAKER RATING	ADAPTOR CAT. No.
400-1000A N/S	BL60967O000
400-1000A H	BL60968O000

BREAKER RATING	DIMENSION A
400 - 1000A N/S	74
400 - 1000A H	72

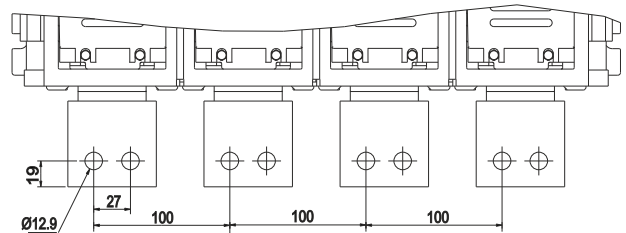
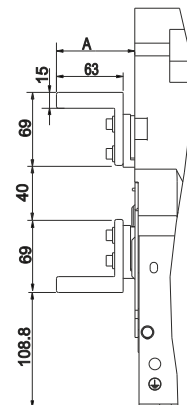
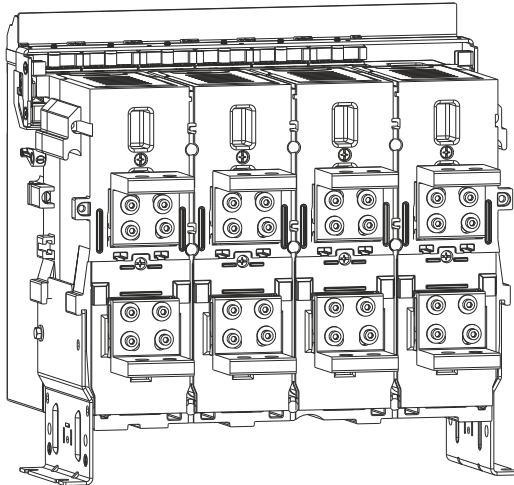

M12 / Equivalent BS bolts to be used for link termination
Tightening torque: 3.2 kgfm

Termination - Fixed Breakers



Vertical Terminals 400A-1000A N/S Fr.1-4P (200% N)

BREAKER RATING	ADAPTOR CAT. No.
400-1000A N/S	BLCA609670000

BREAKER RATING	DIMENSION A
400 - 1000A N/S	74

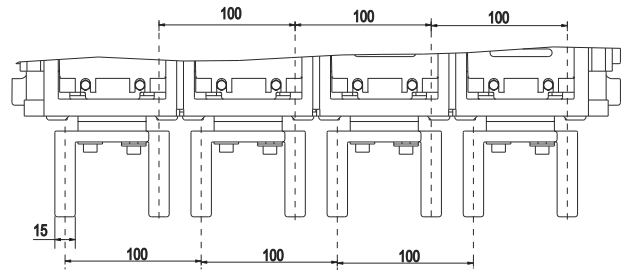
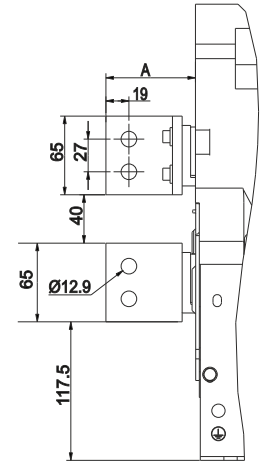
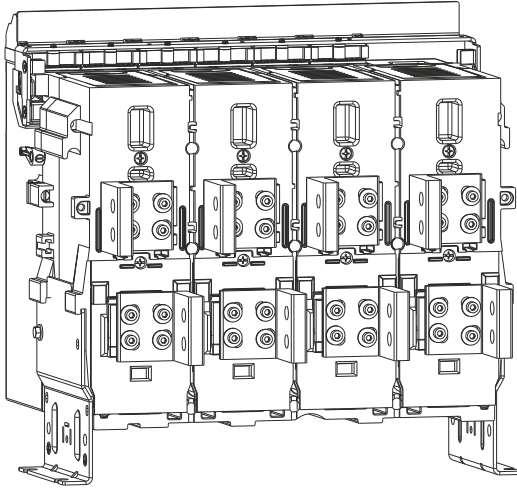

M12 / Equivalent BS bolts to be used for link termination
Tightening torque: 3.2 kgfm

Vertical Terminals 1250A N/S Fr.1-4P (200% N) (Adaptor-BLCA609760000)

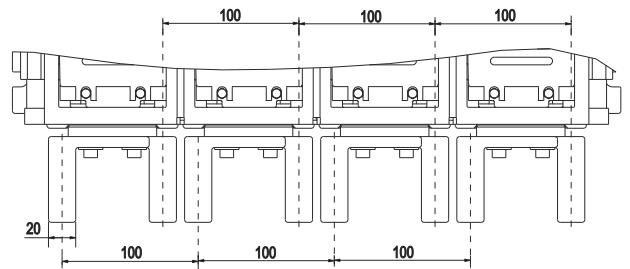
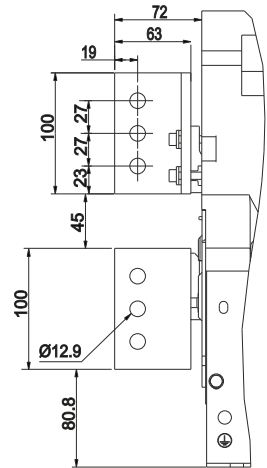
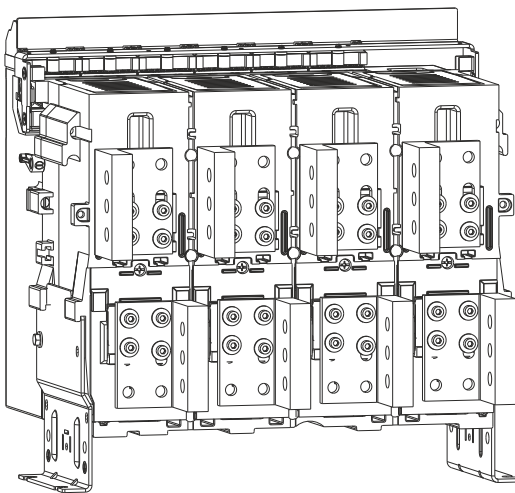

M12 / Equivalent BS bolts to be used for link termination
Tightening torque: 3.2 kgfm

Termination - Fixed Breakers



Flat Termination

400A-1600A N/S/H Fr.2-4P (200% N)

VERSION	A	B	C	D	E
400 -1250A N/S	24	24	81.2	11	50
1600A N/S	30	30	98.4	9	55
400-1600A H	30	30	98.4	9	55

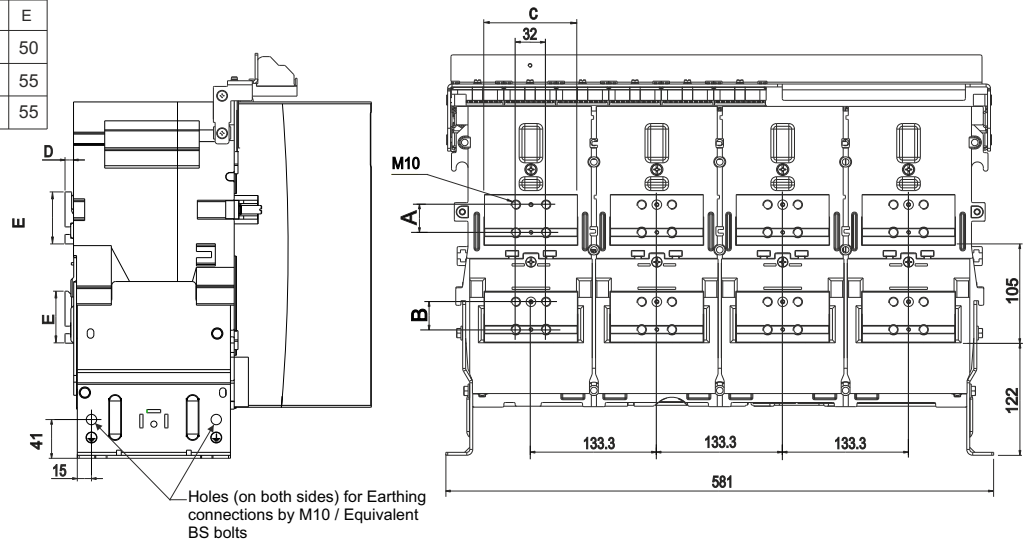

M10 bolts to be used for link termination
Tightening torque: 3.0 kgfm

Horizontal Termination

400A-2000A N*/S/H Fr.2-4P (200% N)

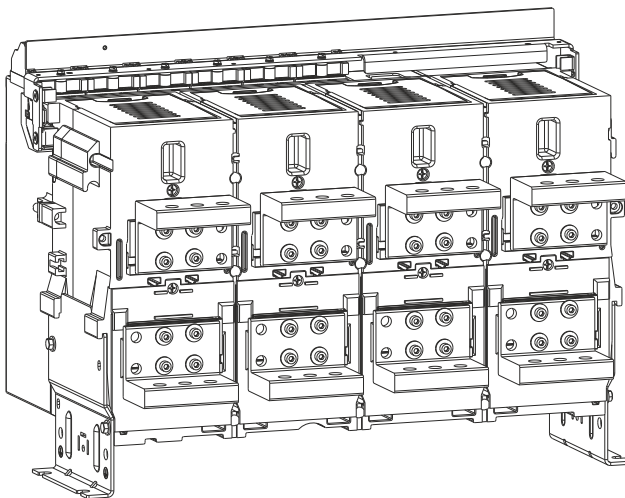

VERSION	ADAPTOR
400 -1250A N/S	BLCA60122O000
1600 - 2000A N*/S	BLCA60977O000
400 - 2000A H	BLCA60977O000

VERSION	DIMENSION A
400 - 1250A N/S	74
1600 - 2000A N*/S	72
400-2000A H	72

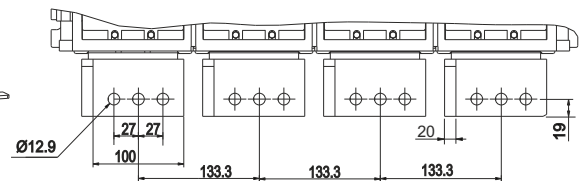
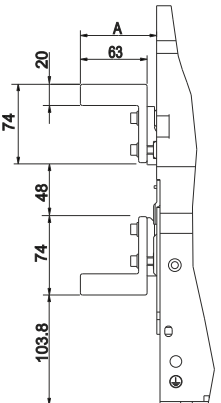

* Available till 1600A

M12 / Equivalent BS bolts to be used for links termination
Tightening torque: 3.2 kgfm

Vertical Termination

400A-2000A N*/S/H Fr.2-4P (200% N)

VERSION	ADAPTOR
400-1250A N/S	BLCA601220000
1600-2000A N*/S	BLCA609770000
400-2000A H	BLCA609770000

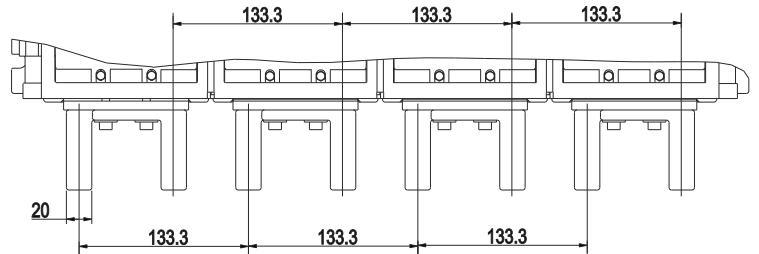
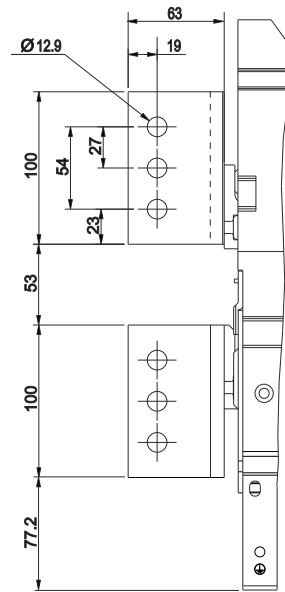
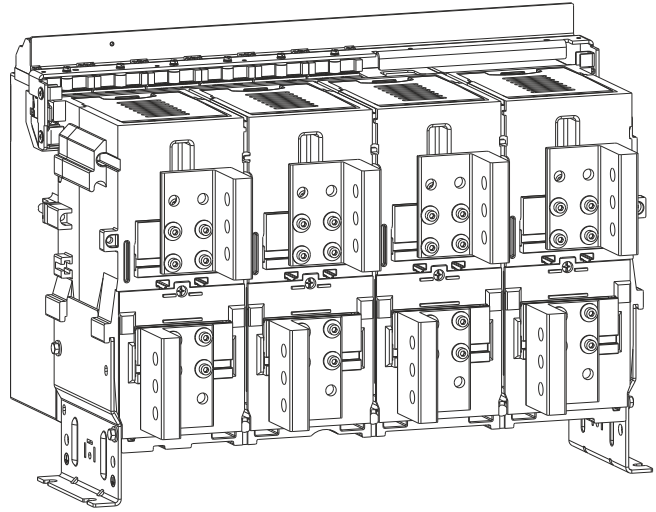

* Available till 1600A

M12 / Equivalent BS bolts to be used for links termination
Tightening torque: 3.2 kgfm

Termination - Fixed Breakers



Flat Termination

400A-1600A H/V Fr.3-4P(200% N)



Bolt length for mounting link(s) on Flat Terminals To be cumulative link(s) Thickness + 15 mm.

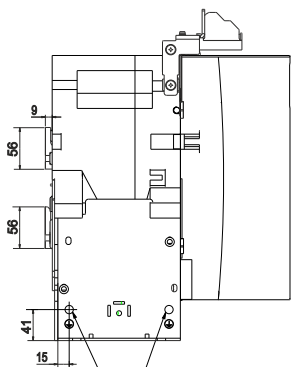

Holes (on both sides) for Earthing connections by M10 / Equivalent BS bolt

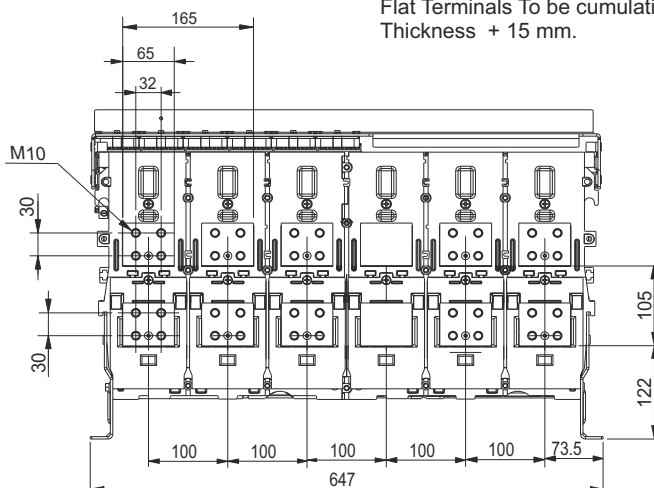

M10 to be used for links termination
Tightening torque: 3.0 kgfm

Horizontal Termination (Bus Coupler Application Only)

400A-2500A H/V Fr.3-4P (200% N)

Adaptor - BLCA603730000

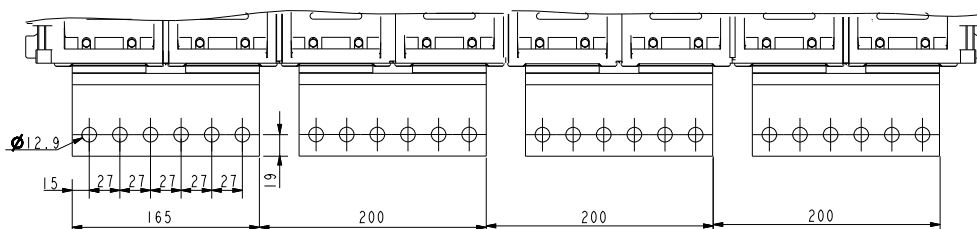
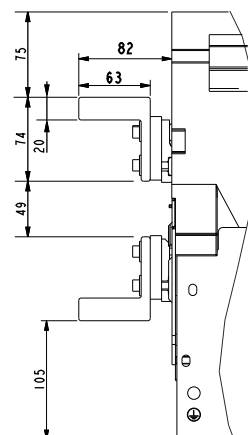
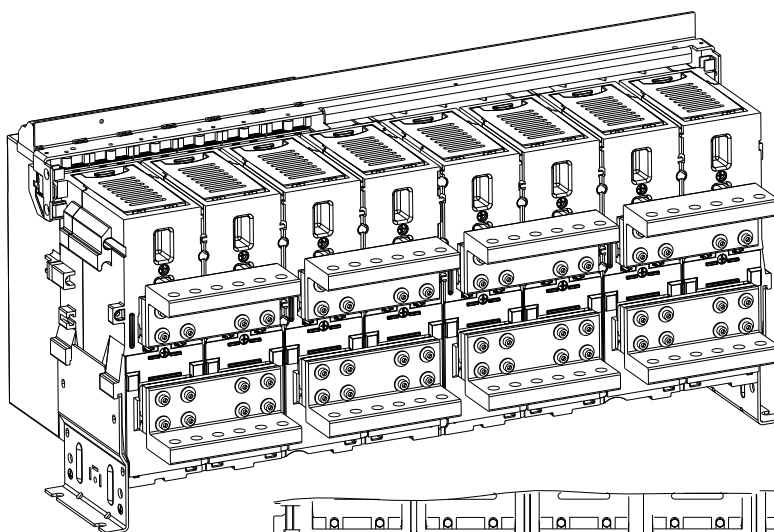

M12 / Equivalent BS bolts to be used for links termination
Tightening torque: 3.2 kgfm

Termination - Fixed Breakers



P Vertical Termination
 400A-2500A H/V Fr.3-4P (200% N)

Breaker Rating	Adaptor Cat. No.	Dim. A	Dim. B	No of Holes
400-2500A	BLCA604180000	125	61	4

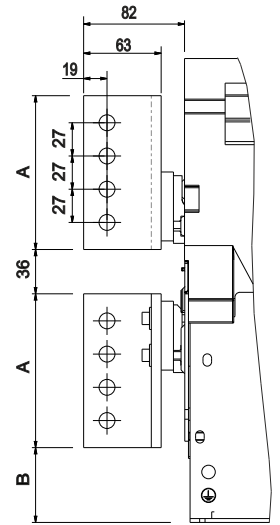
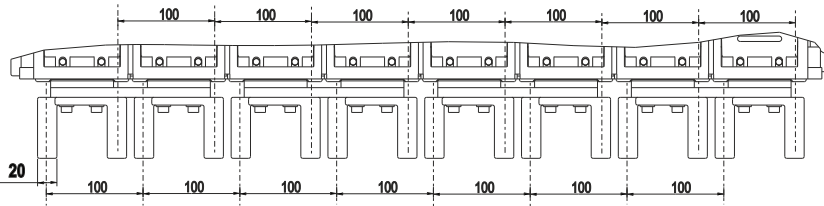
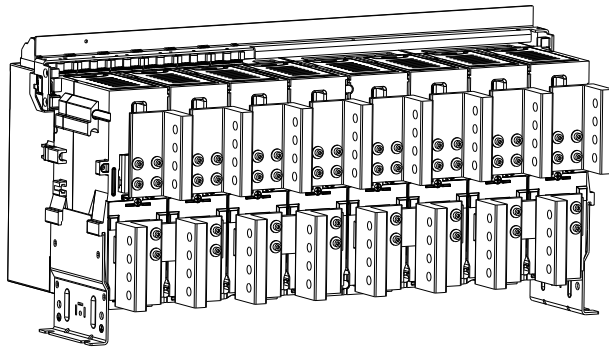

M12 / Equivalent BS bolts to be used for links termination
 Tightening torque: 3.2 kgfm

Termination - Draw-out Breakers

400A-1000A, N/S/H, Fr.1-4P (200%N)



Flat Terminals

400A-1000A, N/S/H

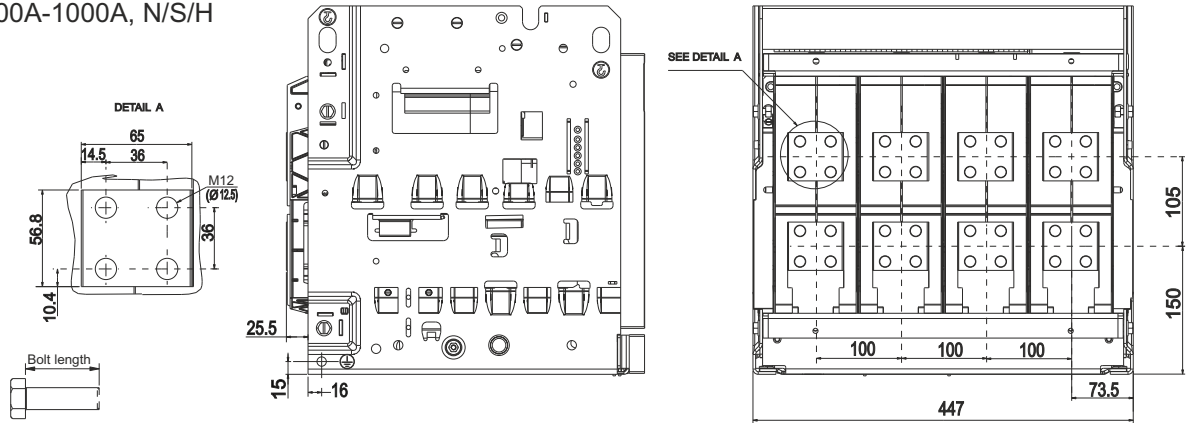

Bolt length for mounting link(s) on Flat Terminals to be cumulative link(s) thickness +20 min to 25 max.

M12 bolts to be used for link termination
Tightening torque: 3.2 kgfm

Horizontal Terminals

400A - 1000A N/S/H
Adaptor - BLCA609630000

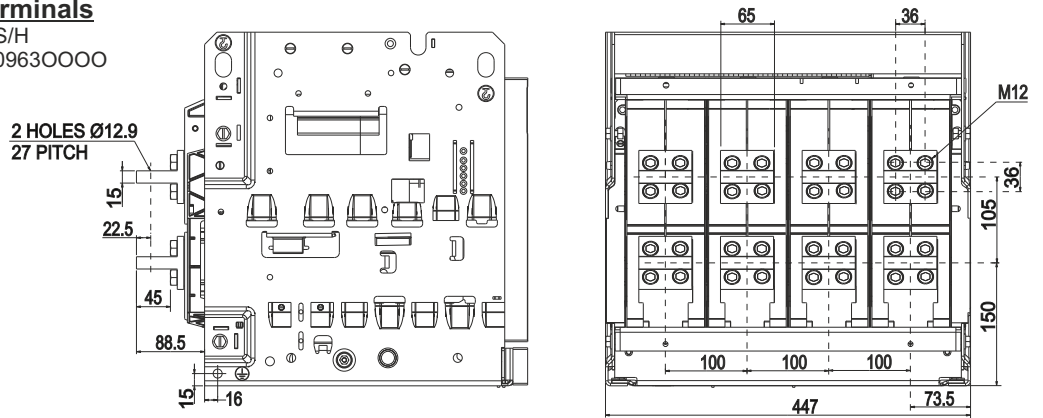

Vertical Terminals

400A - 1000A N/S/H
Adaptor - BLCA609630000

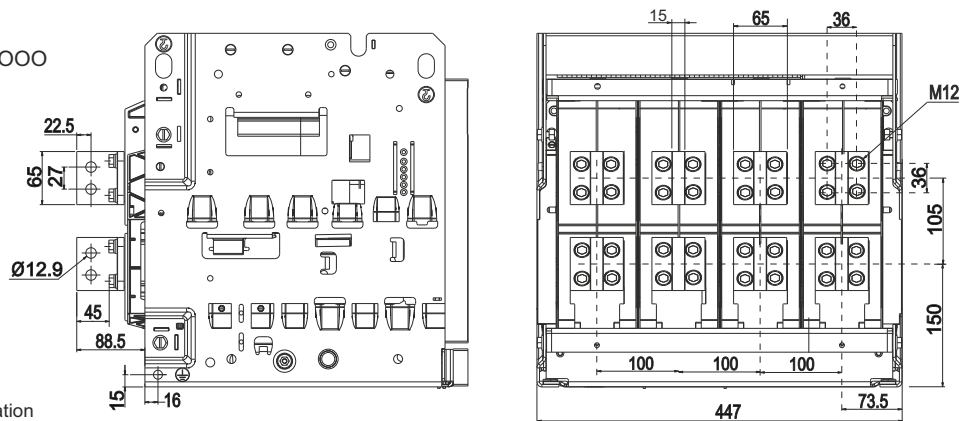

M12 / Equivalent BS bolts to be used for links termination
Tightening torque: 3.2 kgfm

All Dimensions in mm

Termination - Draw-out Breakers



Flat Terminals

400A-1600A, N/S/H, Fr.2-4P (200% N)

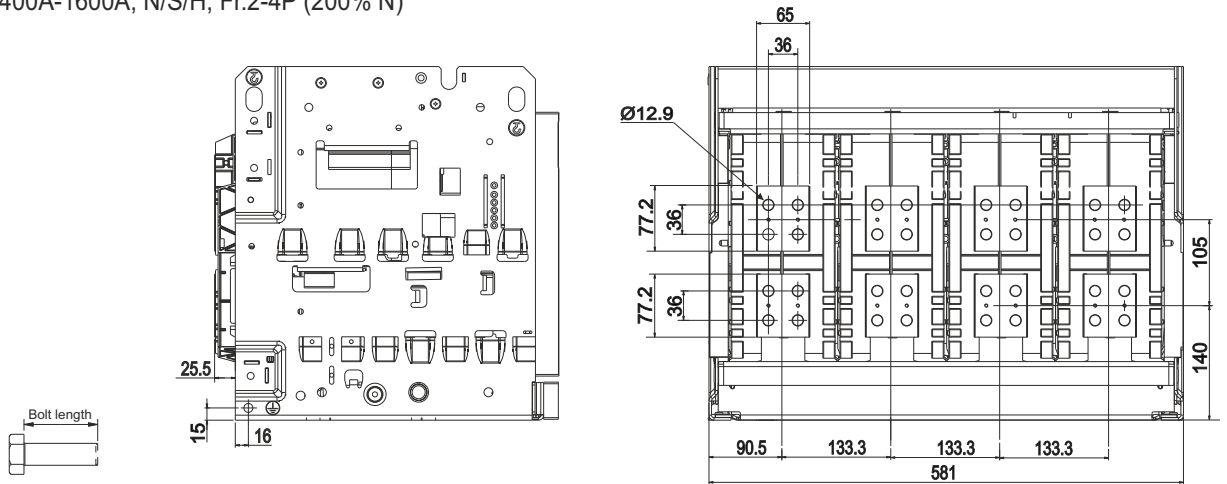

Bolt length for mounting link(s) on Flat Terminals to be cumulative link(s) thickness+20 min to 25 max

M12 bolts to be used for link termination
Tightening torque: 3.2 kgfm

Horizontal Terminals

400A-2000A N*/S/H (200% N)

Adaptor - BLCA609640000

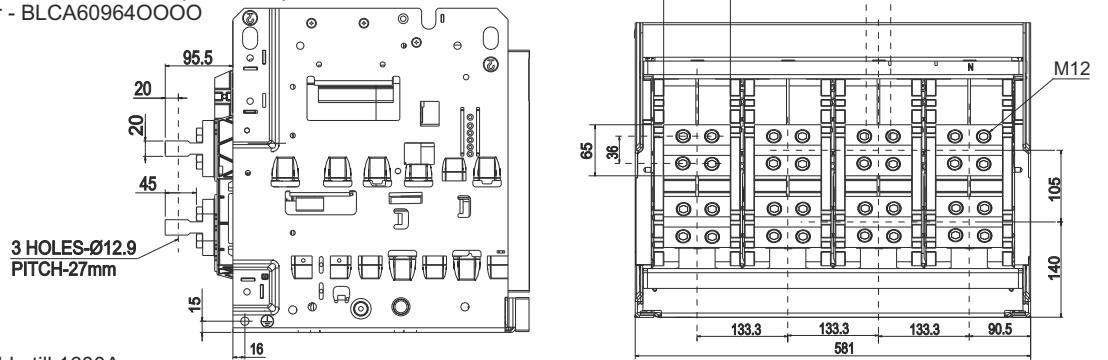

* Available till 1600A

Vertical Terminals

400A-2000A N*/S/H (200% N)

Adaptor - BLCA609640000

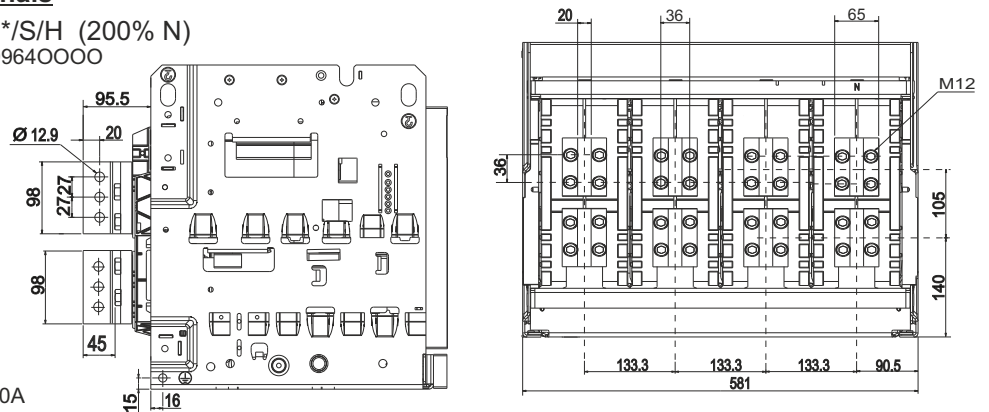

* Available till 1600A

M12 / Equivalent BS bolts to be used for links termination.
Tightening torque: 3.2 kgfm

Termination - Draw-out Breakers

400A-2000A H/V, Fr.3-4P (200%N)

Flat Terminals 400A-1600A H/V

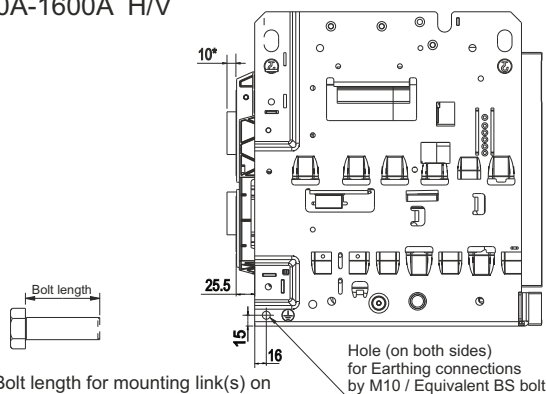

Bolt length for mounting link(s) on Flat Terminals to be cumulative link(s) thickness+20 min to 25 max

Horizontal Terminals (Bus Coupler Application Only)

400A-2500A H/V
Adaptor - BLCA600730000

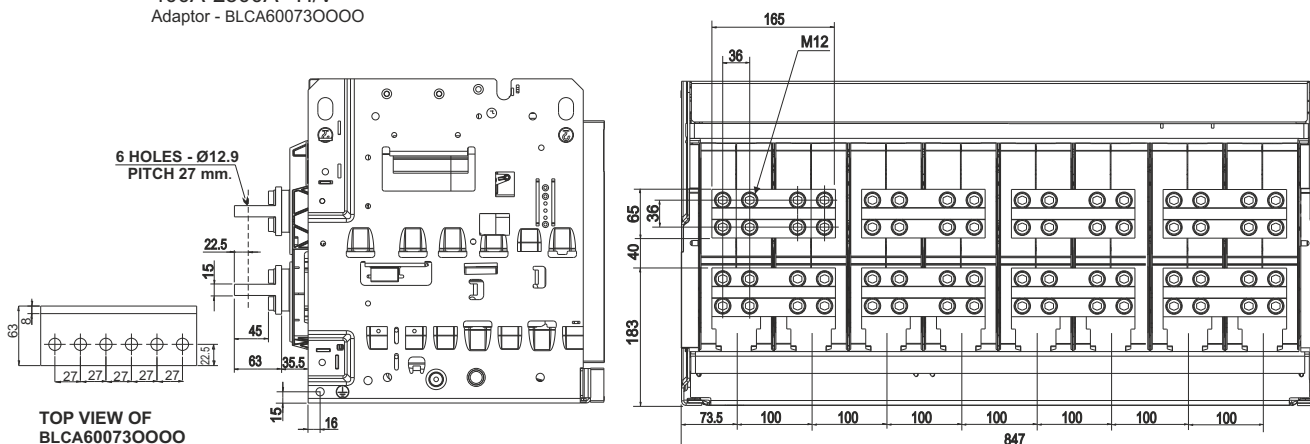

TOP VIEW OF BLCA600730000

Vertical Terminals

400A-2500A H/V
Adaptor - BLCA601280000

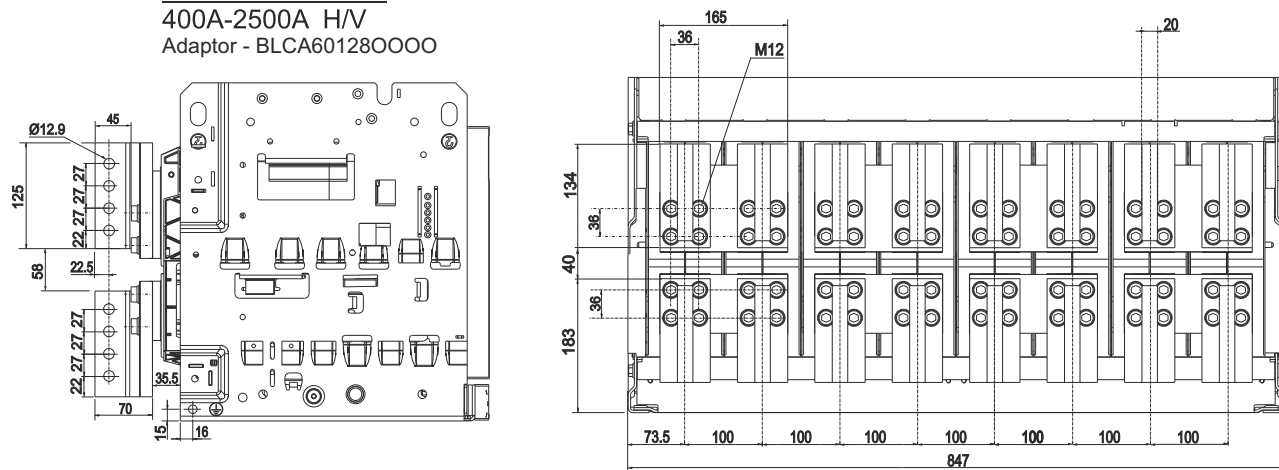

M12 / Equivalent BS bolts to be used for links termination.
Tightening torque: 3.2 kgfm

All Dimensions in mm

External Neutral CT:

For Earth fault protection and protection of Neutral against overloads, Neutral CT is required. For 4-Pole breakers, the CT is provided inside the breaker, to be used on 4 wire system whereas for 3-pole breakers, external CT is available separately.

It is important that, special neutral CTs supplied by are used.

Frame Size	Rating
1, 2 & 3	400/630/800
1, 2 & 3	1000/1250/1600

(ref. Page 2-6 for Frame size details)

TERMINAL THICKNESS 15 mm.

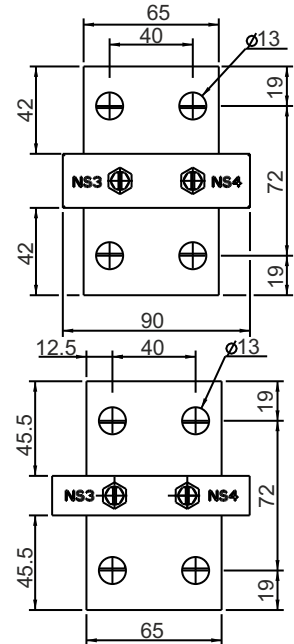
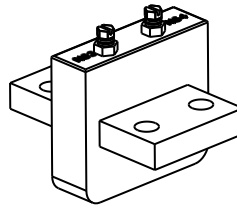

Frame Size	Rating
1	2000/2500

(ref. Page 2-6 for Frame size details)

TERMINAL THICKNESS 30 mm.

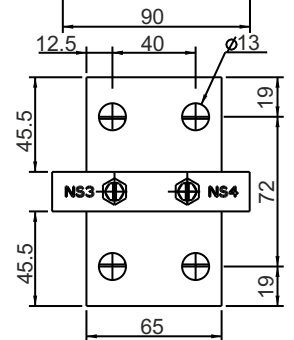
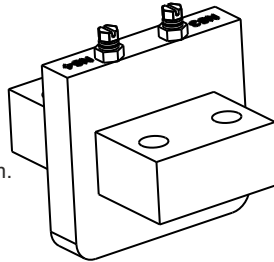

Frame Size	Rating
2 & 3	2000/2500/ 3200/4000

(ref. Page 2-6 for Frame size details)

TERMINAL THICKNESS 30 mm.

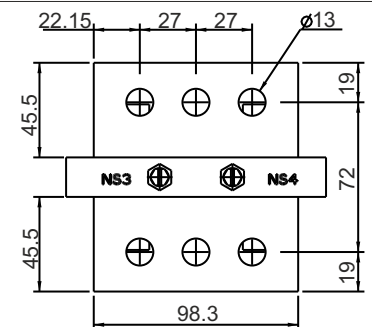
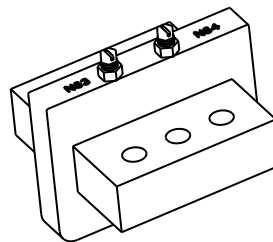

Frame Size	Rating
3	5000/6300

(ref. Page 2-6 for Frame size details)

TERMINAL THICKNESS 30 mm.

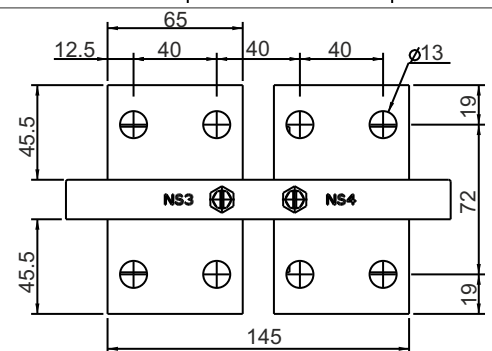
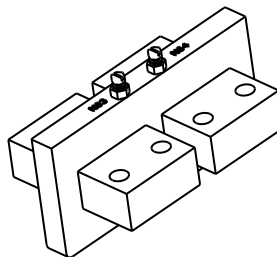

M12 / Equivalent bolts to be used for links termination.
Tightening torque: 3.2 kgfm
All Dimensions in mm

3.3 Loading in panel:

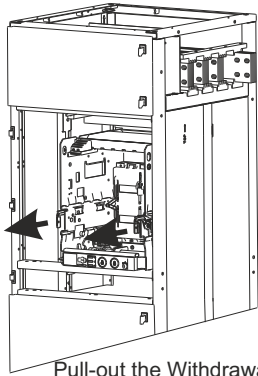

1

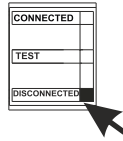

Pull-out the Withdrawal Rails (25) & ensure that position indication (17) shows 'DISCONNECTED'.

2

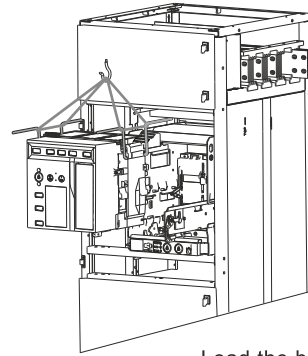

Load the breaker using crane. Even bottom trolley can be used.

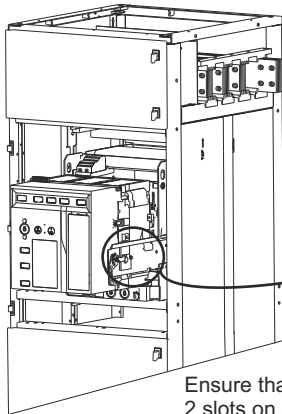

3

Ensure that Breaker rests correctly in 2 slots on either side of cradle rail (38).

CAUTION

Improper loading of breaker may lead to personal injury and damage to product.

4

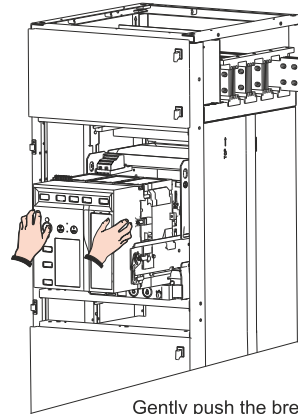

Gently push the breaker to DISCONNECTED position and close the Panel door. If equipped with Rating Error Preventor (23), Cradle will not accept breaker of different rating & breaking capacity.

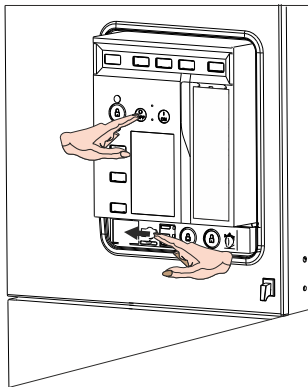

5

Keeping the OFF button (11a) pressed, open the Racking Shutter (16). In case panel door is open, also gently depress the Door Racking Interlock (26).

6

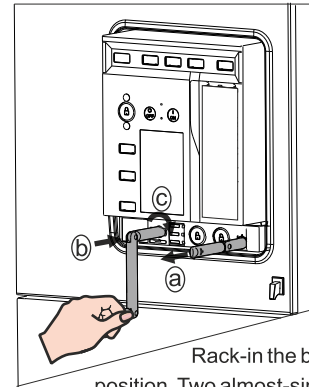

Rack-in the breaker to Service position. Two almost-simultaneous 'Click' sounds confirm 'CONNECTED' position.

CAUTION

Excessive forceful racking-in beyond Connected position may lead to product damage.

3.4 Control Circuit Connections:

Secondary Isolating contacts (8b) facilitate Control circuit wiring with following features,

- Cradle SIC block slot & each breaker SIC slot is pre-defined and marked for specific connections (Ref. page 3-37).
- Breaker is supplied with SIC as per the order configuration.
- Every accessory comes pre-wired with breaker SICs. SIC location is printed on the wire for easy identification.
- Breaker SIC are click-fitted and hence, require no tools for fixing. Cradle SIC block is mounted with a screw driver.
- SICs offer screwless wire connections, by simply using a connector as shown in the diagram.
- SICs can independently accept 2 wires for ease of terminating multiple wires. Wire specifications: Min 0.75 mm² & Max 2.5 mm².
- After termination, control wires can be routed through guides provided in the cradle side plates.

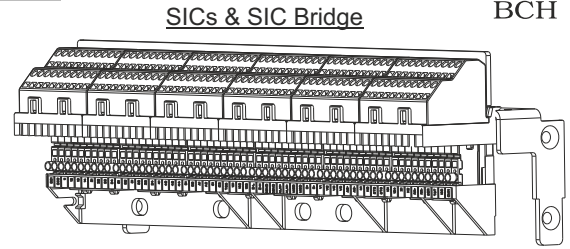

Quick and Easy Control wiring

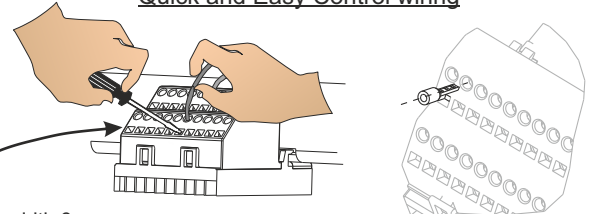

Tip width 3 mm

Strip Conductors

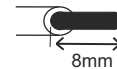

Ensure lug orientation with serrations on top

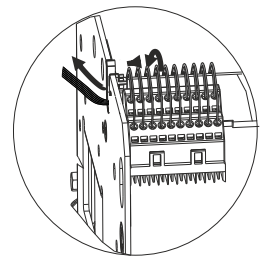

Routing Control wires

CAUTION

Lugs to be used with wires getting inserted into SIC. Do not use wires without lugs.
Wire bunch to be routed properly to avoid interference with Door Interlock (40), if installed.

Electrical Position Indication (EPI):

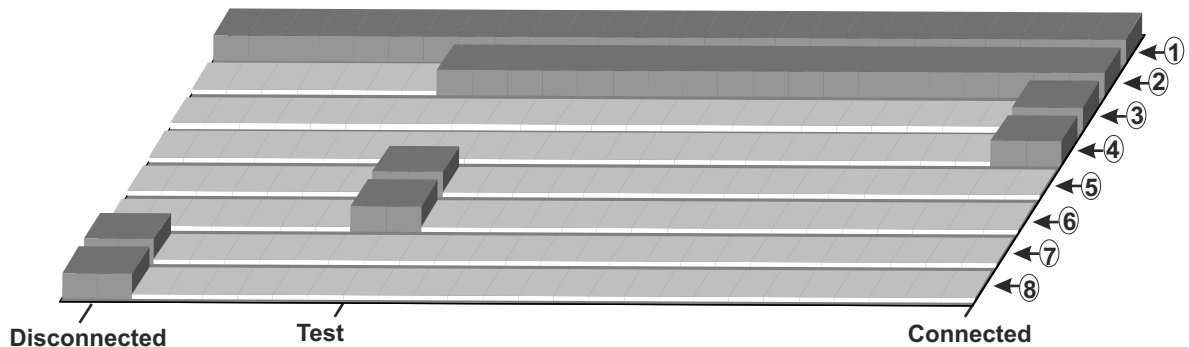

- | | |
|--|---|
| 1 All position SIC | 5 Test position SIC |
| 2 Connected & Test position SIC | 6 Additional Test position indication |
| 3 Connected position SIC | 7 Disconnected position SIC |
| 4 Additional Connected position indication | 8 Additional Disconnected position indication |

Control Termination:

For BU-BTX1.0/1G/1Gi/1.5G/1.5Gi/3.5/3.5EC/3.5H

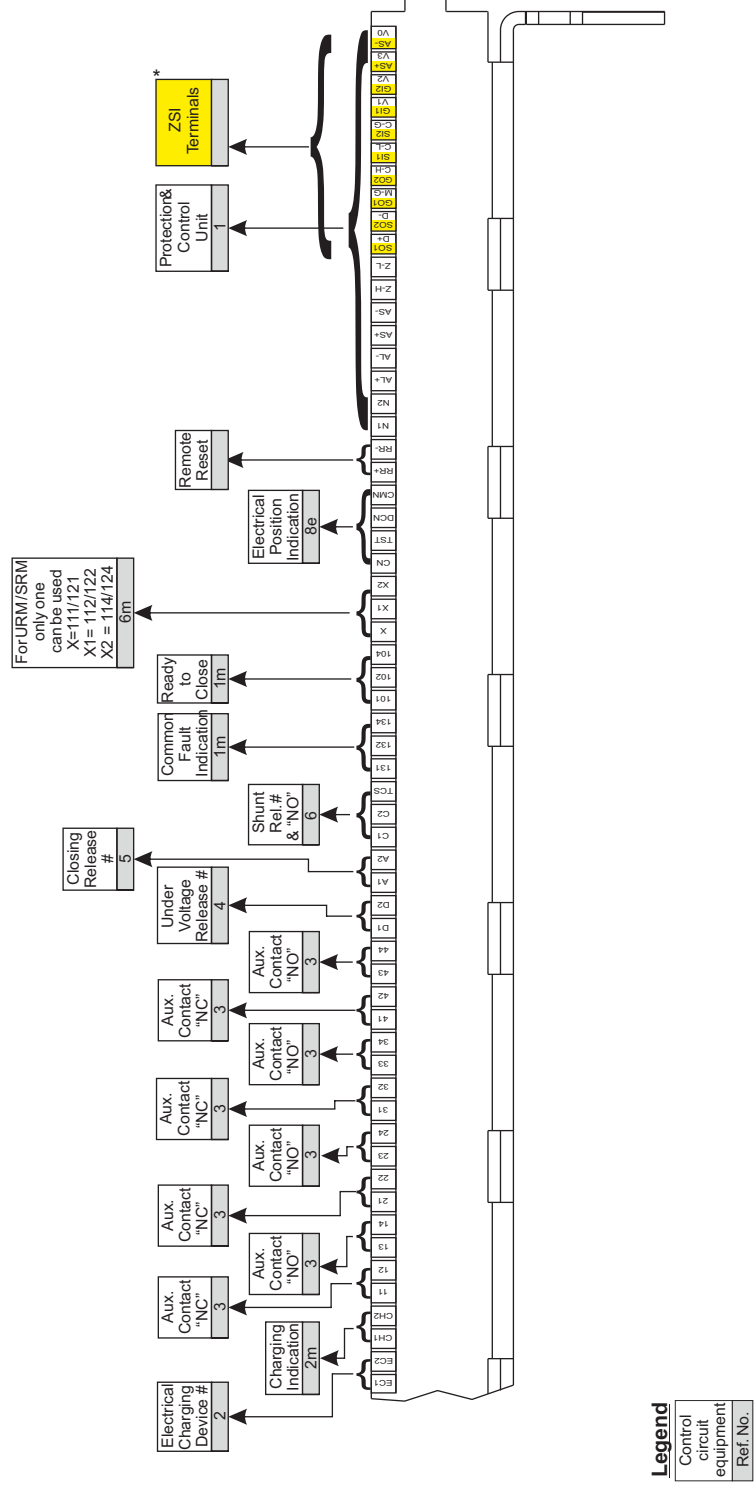

The above diagram gives a generic configuration for control termination on the breaker. For specific details, refer Connection diagram (pages 79 to 84) specific to the P&C unit installed in the breaker.

For using electrical accessories with DC Control Supply, it is recommended to connect D1/A1/C1 to +ve and D2/A2/C2 to -ve.

m indicates micro switch

* These ZSI Terminals should only be used for BTX 1G/1.5Gi Releases.

Connection Details (BU-BTX 1.0)

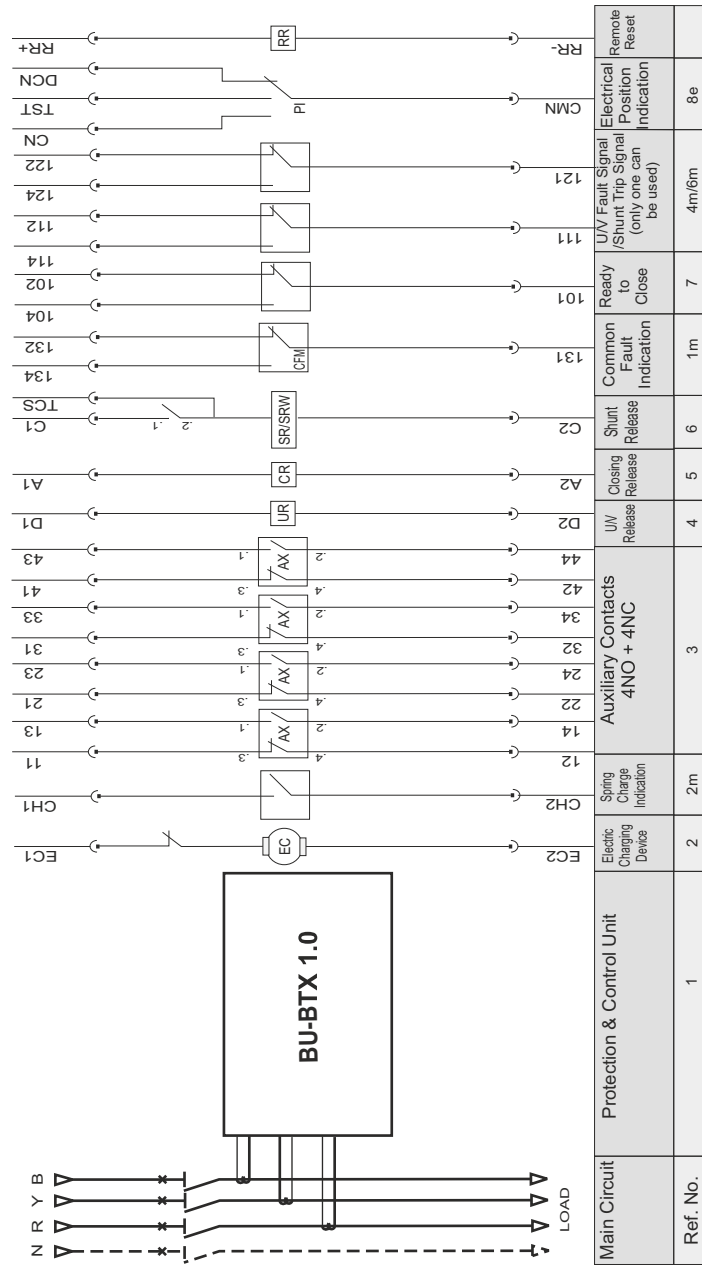

Connection Details (BU-BTX 1G)

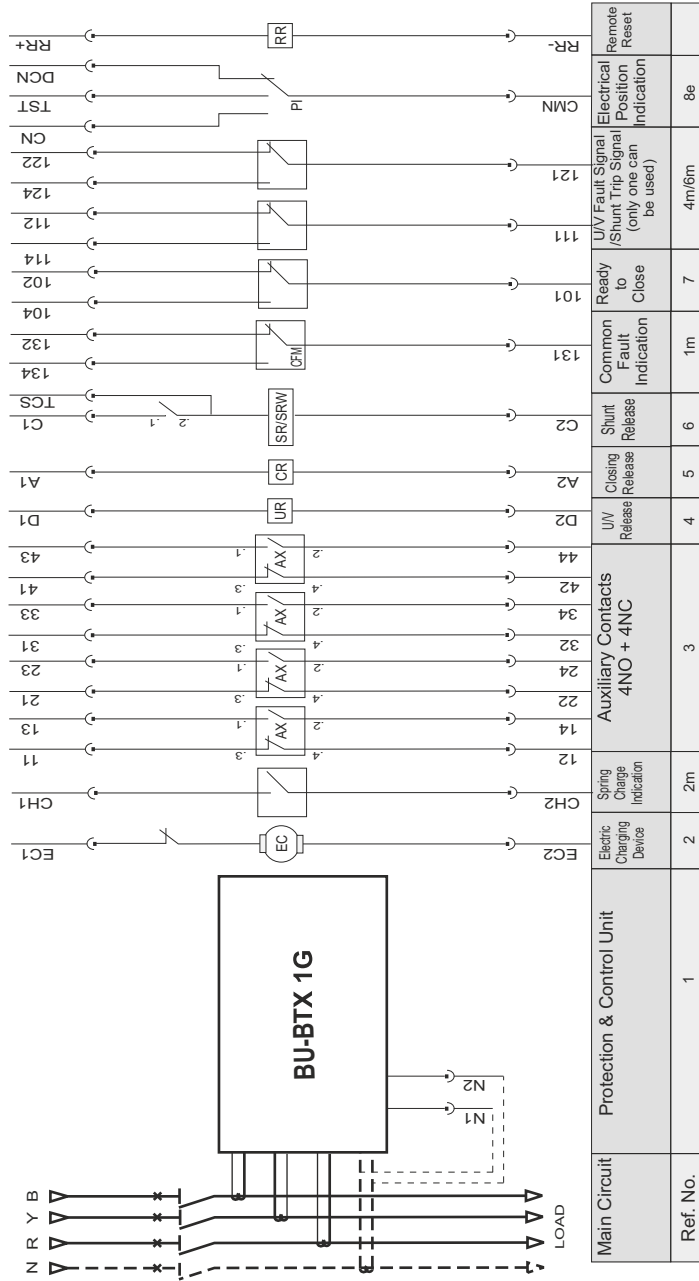

N1, N2 : External Neutral CT

Connection Details (BU-BTX 1.5G)

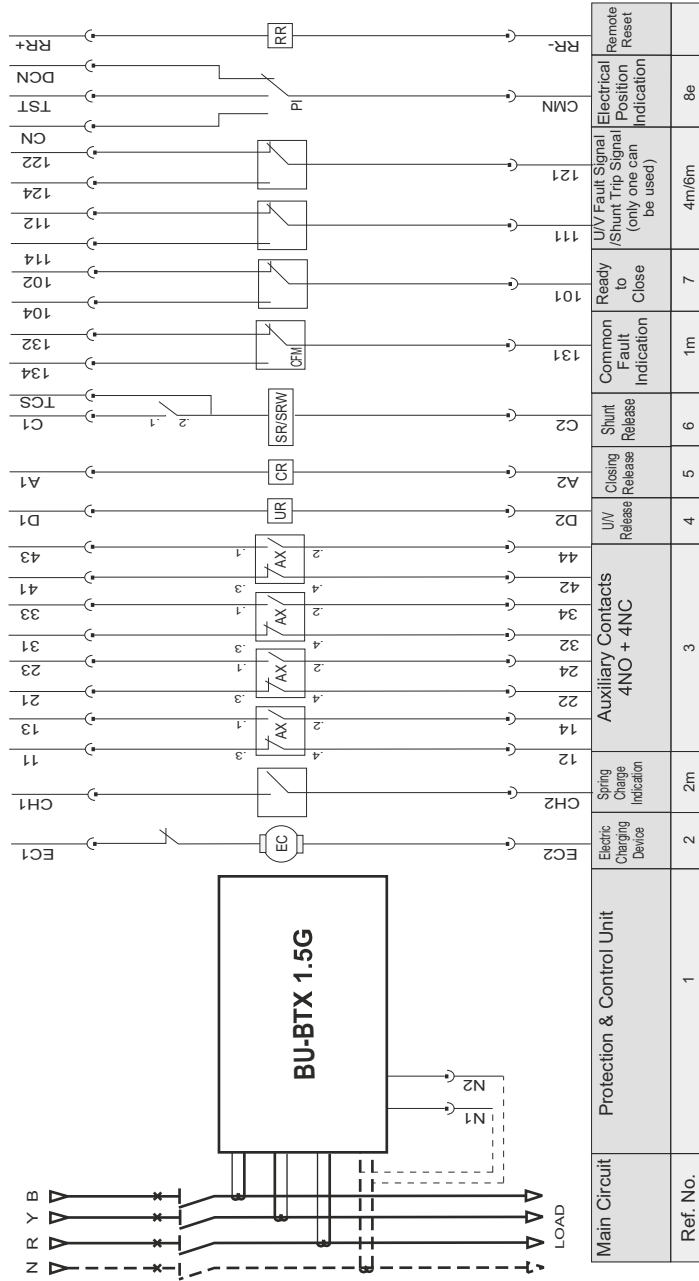

N1, N2 :External Neutral CT

Connection Details (BU-BTX 1Gi / 1.5Gi)

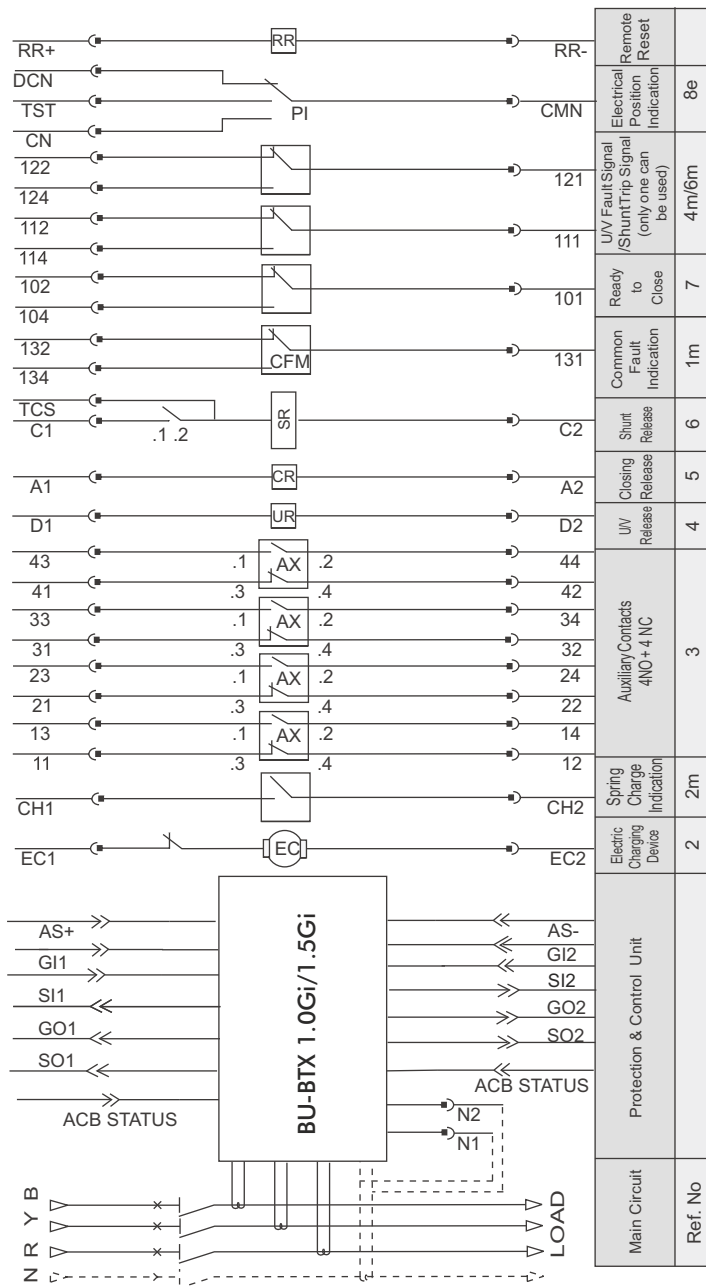

- AS+ : Auxiliary 24 V DC
- AS- : Ground
- SOUT : ZSI S/C Output
- SIN : ZSI S/C Input
- GOUT : ZSI E/F Output
- GIN : ZSI E/F Input
- N1 : External Neutral CT
- N2 : External Neutral CT

Connection Details (BU-BTX 3.5)

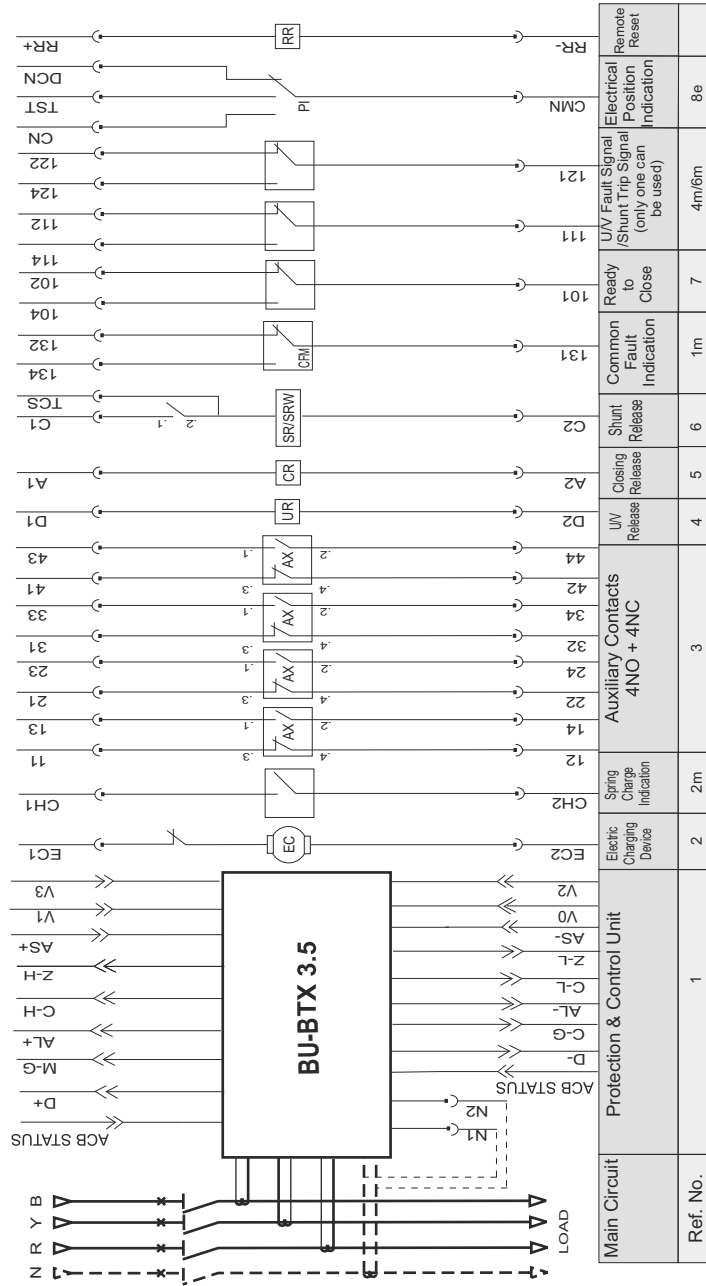

AS+, AS- : 24V DC Power Supply
 AL+, AL- : TRIP ALARM+, TRIP ALARM-
 This output can be connected to 5V-30 V dc 150 mA Relay or any other indicating device which can give alarm for overload.

C-L : CAN-Low
 C-H : CAN-High
 M-G : MOD-GND
 C-G : CAN-GND
 V0, V1, V2, V3 : N, R, Y, B, VOLTAGE I/P.

D+ : MOD A
 D- : MOD B
 N1 : External Neutral CT
 N2 : External Neutral CT
 Z-L : ZSI CAN-Low
 Z-H : ZSI CAN-High

Connection Details (BU-BTX 3.5EC/3.5H)

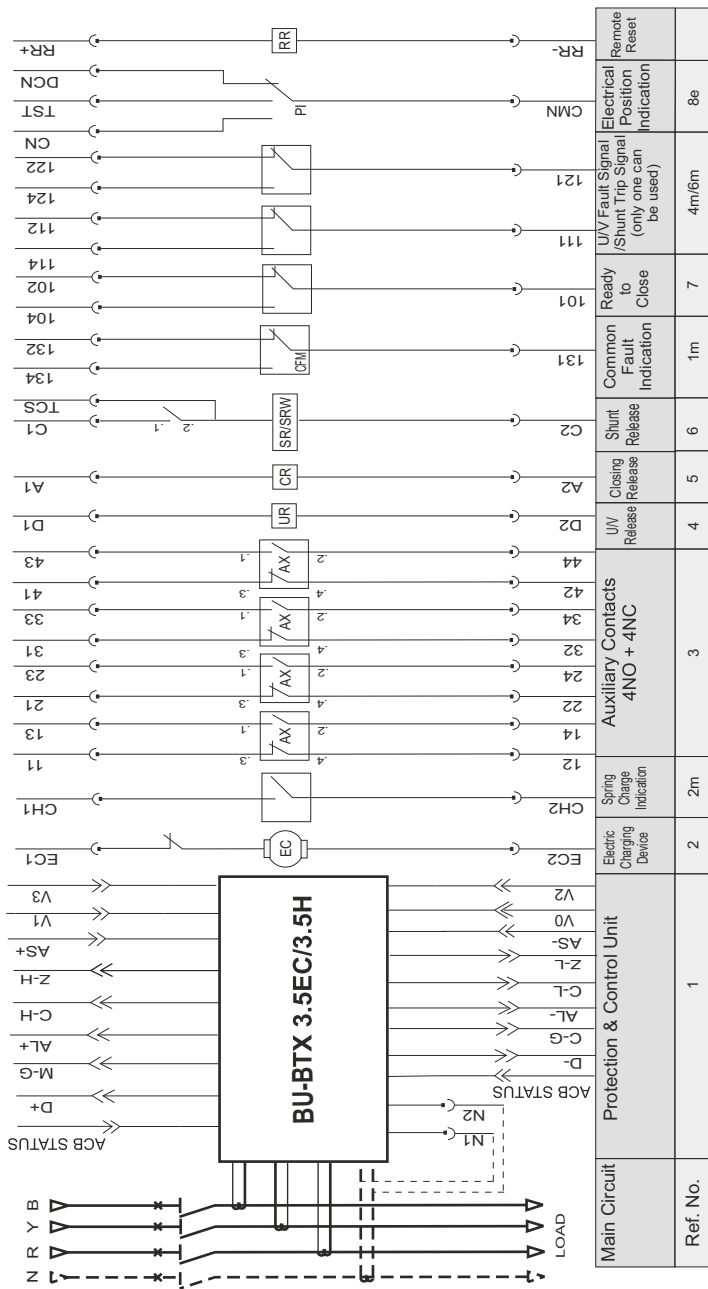

- D+ : MOD A
- D- : MOD B
- N1 : External Neutral CT
- N2 : External Neutral CT
- Z-L : ZSI CAN-Low
- Z-H : ZSI CAN-High

- AS+, AS- : 24V DC Power Supply
 - AL+, AL- : TRIP ALARM+, TRIP ALARM-
- This output can be connected to 5V-30 V dc 150 mA Relay or any other indicating device which can give alarm for overload.

- C-L : CAN-Low
- C-H : CAN-High
- M-G : MOD-GND
- C-G : CAN-GND
- V0, V1, V2, V3 : N, R, Y, B, VOLTAGE I/P.

Section 4

Accessories: Features & Mounting

4.1 Cradle Mounted Accessories

4.2 Breaker Mounted Accessories

4.1 Cradle Mounted Accessories

a. Safety Shutter (39):

Function: To prevent inadvertent access to live terminals.

Features: One or individual pole can be padlocked during maintenance.

Tools required: Screw Driver (Blade length 300 mm, Tip width 8 mm)

Installation: Remove bolt on the bottom cross component (36). Click-fit the shutter on the top cross component (37) and refix the bolt on the bottom cross component. This process has to be repeated for each pole.

Safety Shutters are available for individual pole.

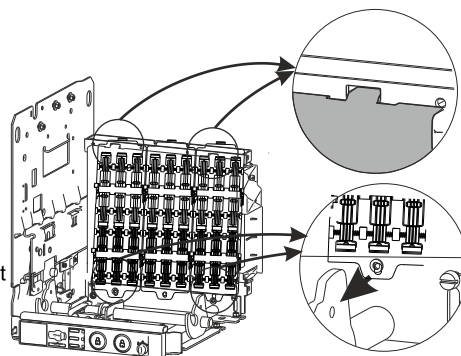

b. Door Interlock (40):

Function: Prevents opening of panel door in Connected & Test positions.

Features: It can be mounted on either side of the cradle and can be converted for RHS hinge doors by simply relocating 2 components.

Tools required: Philip head Screw driver (Tip no.2), Ring spanner (size 13)

Installation: Door interlock comes in 2 parts, one to be fixed on the cradle and the other on the panel door. Door interlock is mounted inside the side plate of the cradle.

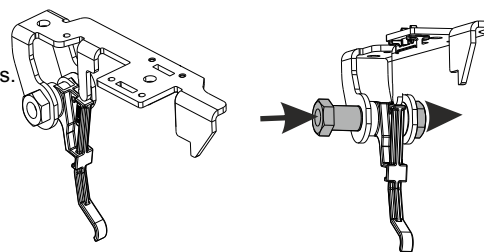

Converting Door-interlock for RHS hinge

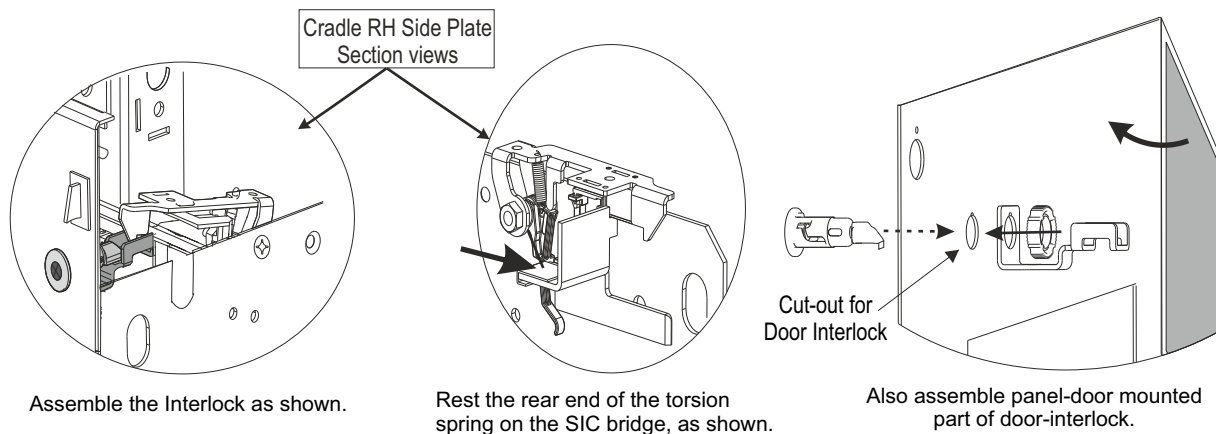

c. Mechanical Interlock:

Function: Mechanical Interlock is used for interlocking breakers as per the desired control scheme.

Features: It can interlock upto 3 breakers of Fixed / Drawout / Mixed versions. The breakers can be interlocked in Vertical or Horizontal configuration.

Possible mounting arrangements:

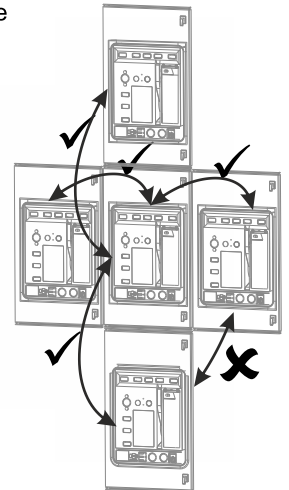

Cable length: 2 meters/3 meters/5 meters
min. radius of cable bend: 70mm

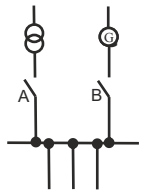
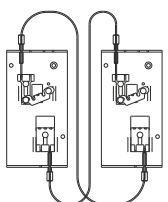
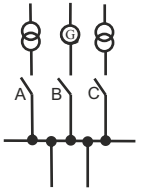
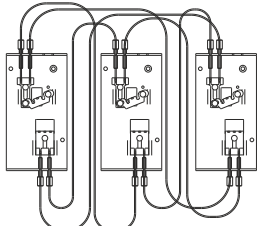
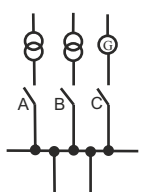
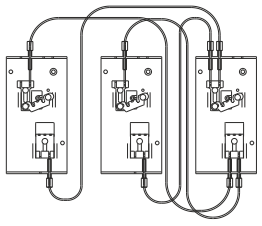
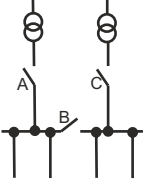
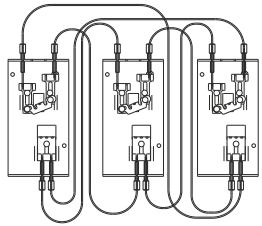
Type of Interlock	Typical Circuit	Interlocks possible	Schematic diagram																								
Two Incomers (2 I/C)		<table border="1"> <tr><td>A</td><td>B</td></tr> <tr><td>O</td><td>O</td></tr> <tr><td>I</td><td>O</td></tr> <tr><td>O</td><td>I</td></tr> </table>	A	B	O	O	I	O	O	I																	
A	B																										
O	O																										
I	O																										
O	I																										
Three Incomers (3 I/C)		<table border="1"> <tr><td>A</td><td>B</td><td>C</td></tr> <tr><td>O</td><td>O</td><td>O</td></tr> <tr><td>I</td><td>O</td><td>O</td></tr> <tr><td>O</td><td>I</td><td>O</td></tr> <tr><td>O</td><td>O</td><td>I</td></tr> </table>	A	B	C	O	O	O	I	O	O	O	I	O	O	O	I										
A	B	C																									
O	O	O																									
I	O	O																									
O	I	O																									
O	O	I																									
Two Incomers & One Standby (2 I/C + 1 S/B)		<table border="1"> <tr><td>A</td><td>B</td><td>C</td></tr> <tr><td>O</td><td>O</td><td>O</td></tr> <tr><td>I</td><td>O</td><td>O</td></tr> <tr><td>O</td><td>I</td><td>O</td></tr> <tr><td>O</td><td>O</td><td>I</td></tr> </table>	A	B	C	O	O	O	I	O	O	O	I	O	O	O	I										
A	B	C																									
O	O	O																									
I	O	O																									
O	I	O																									
O	O	I																									
Two Incomers & One BusCoupler (2 I/C + 1 B/C)		<table border="1"> <tr><td>A</td><td>B</td><td>C</td></tr> <tr><td>O</td><td>O</td><td>O</td></tr> <tr><td>I</td><td>O</td><td>O</td></tr> <tr><td>O</td><td>I</td><td>O</td></tr> <tr><td>O</td><td>O</td><td>I</td></tr> <tr><td>O</td><td>I</td><td>I</td></tr> <tr><td>I</td><td>O</td><td>O</td></tr> <tr><td>I</td><td>O</td><td>I</td></tr> </table>	A	B	C	O	O	O	I	O	O	O	I	O	O	O	I	O	I	I	I	O	O	I	O	I	
A	B	C																									
O	O	O																									
I	O	O																									
O	I	O																									
O	O	I																									
O	I	I																									
I	O	O																									
I	O	I																									

O - Breaker Open

I - Breaker Closed

Installation: Mechanical interlock can be mounted on right side of the breaker as follows,

Tools required: Screw Drivers (Tip widths 8 mm & 6 mm), Open spanner (10/11)

a. Mounting actuator
(Common for Fixed & Draw-out breakers)

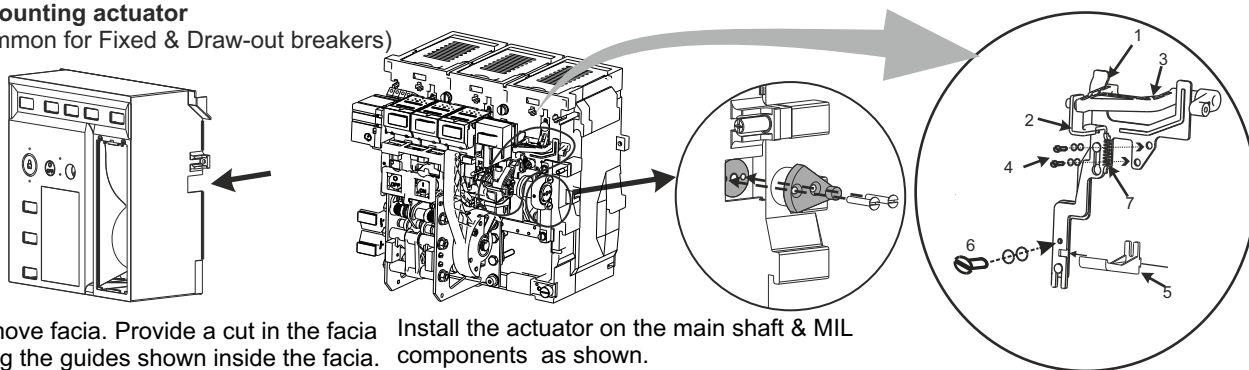

Remove facia. Provide a cut in the facia along the guides shown inside the facia. Install the actuator on the main shaft & MIL components as shown.

b. Fixing the Mechanical Interlock plate
Fixed Breaker

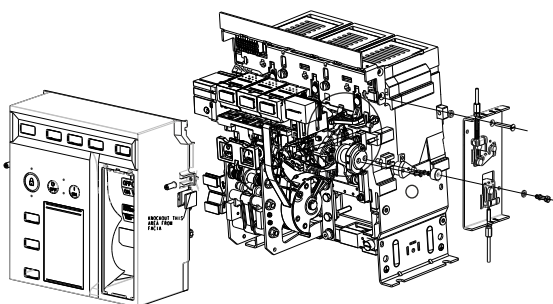

Draw-out Breaker

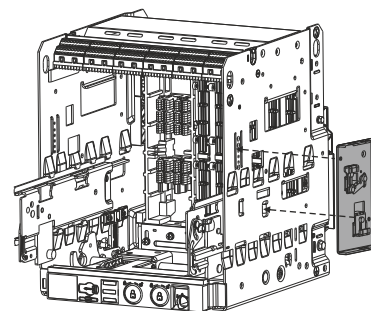

c. Making Cable connections

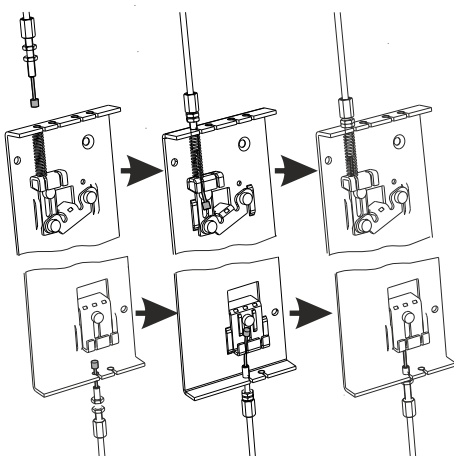

d. Adjustments

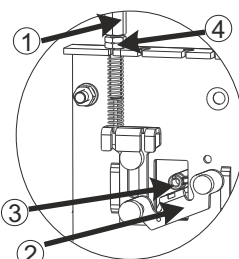

For 2I/C, 3I/C & 2I/C+1S/B:
i. Adjust the Screw (1) till Actuator link (2) just touches Actuator on breaker (3).
ii. Tighten Nut & locknut (4).

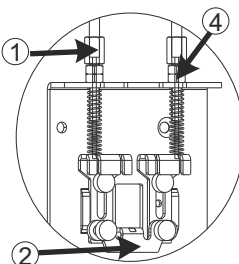

For 2I/C+1B/C:
i. Adjust the Screw (1) till Actuator link (2) is horizontal and is in lowermost position.
ii. Tighten Nut & locknut (4).

CAUTION Mechanical Interlock, once installed, must be tested for all possible combinations before actual operation.

Mounting / Installing Cable Wires

Routing of cable should be with no slip arrangement.

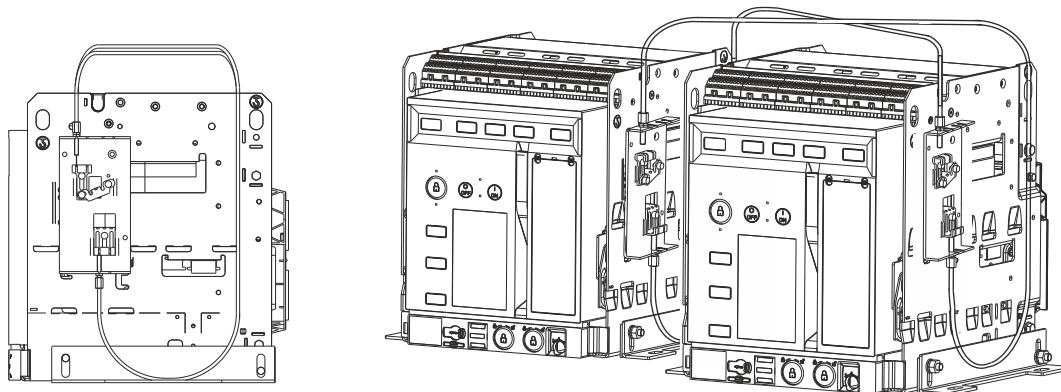

CAUTION

Ensure no free hanging of cable wire. All cable wires should be supported appropriately & rigidly at required no. of locations.
Ensure cables are at safe distance (min 50mm) from live parts.

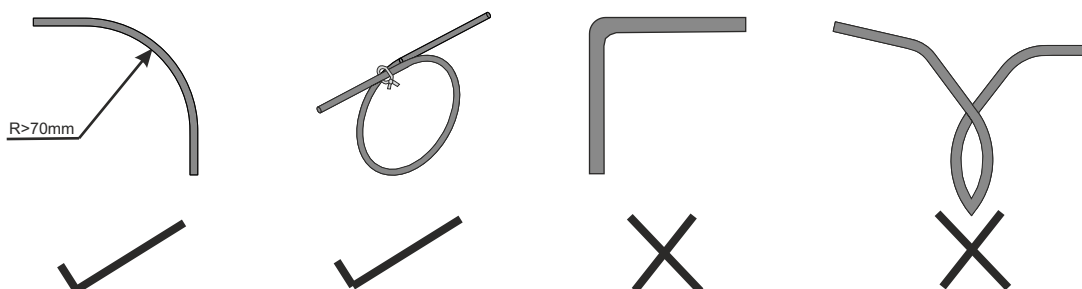
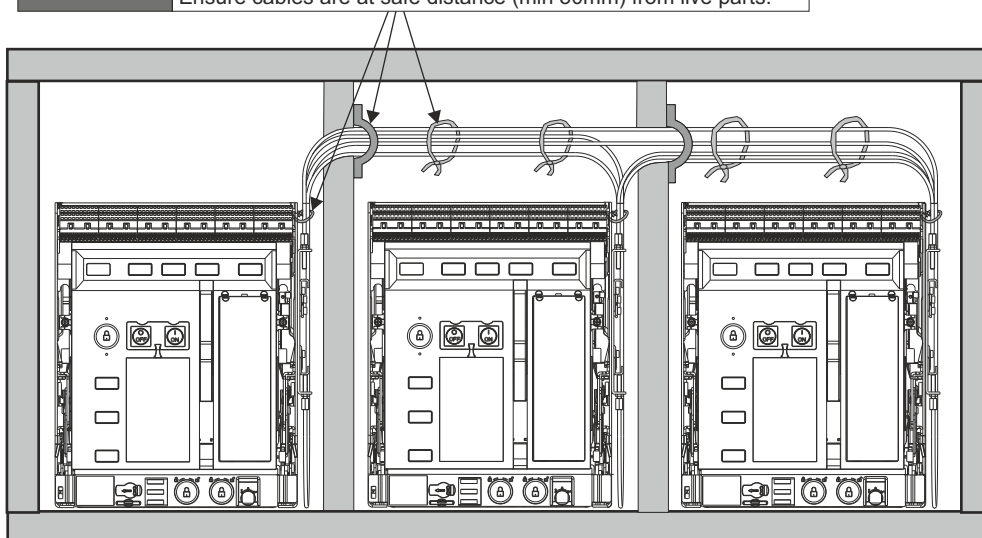

4.2 Breaker Mounted Accessories

Removing facia

Tools required: Screw Driver (Tip width: 8 mm)

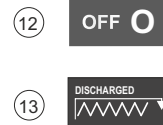
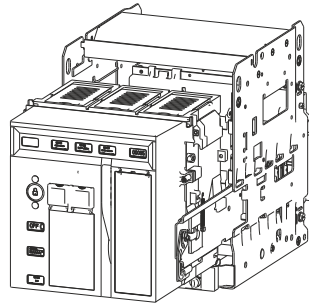

Facia needs to be removed for fixing/replacing various accessories.

CAUTION

To avoid possibility of personal injury, ensure that before opening the facia, breaker is OFF and Spring is discharged.

Facia can be easily removed only in fully drawn-out (Maintenance) position, which ensures safety of USERS and equipment.

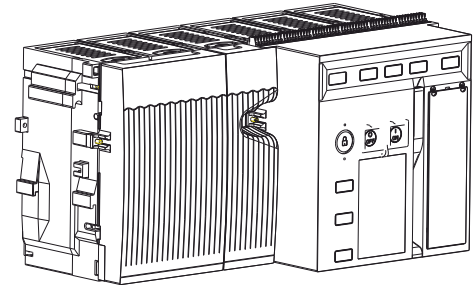
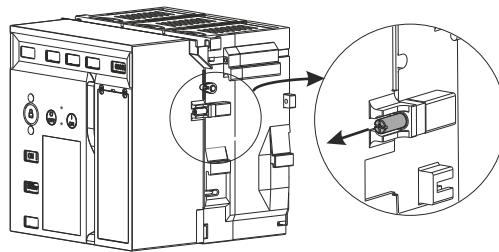

Facia can be taken out by removing 2 screws (32) on either side of the facia.

This is true even for higher frame sizes, where side covers need not be removed for taking out the facia.

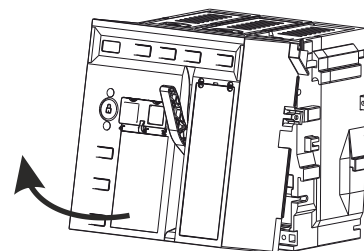
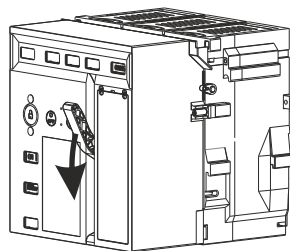

After removing the screws on both sides, pull down the charging handle (14) half-way.

Take out the facia by tilting it upwards as shown.

Several Breaker-mounted accessories are located on the front top side of the breaker and have specific positions.

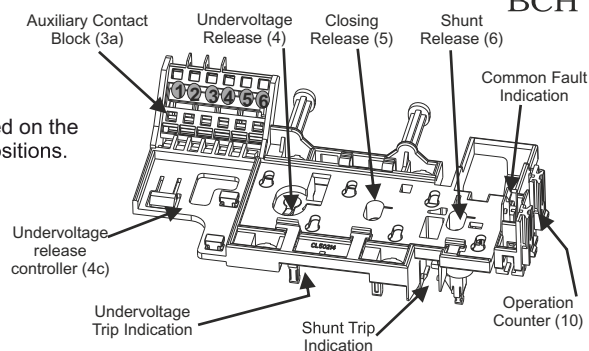

a. Auxiliary contact block - AUX :

Function: To reflect breaker ON/OFF state in the control circuit.

Features: Auxiliary contact block is a combination of 4 units of 1NO+1NC each.

Rated insulation voltage U_i ; 400 V AC/DC

Rated operational voltage U_o ; 400 V AC/DC

Switching capacity:

AC	U_o	upto 24V	110V	220/230V	400V
50/60 Hz.	I_n (AC-12)	10A	10A	10A	10A
	I_n (AC-15)	6A	6A	6A	4A
DC	U_o	24V	48V	110V	220V
	I_n (DC-12)	10A	8A	3.5A	1A
	I_n (DC-13)	10A	4A	1.2A	0.4A

Refer section 7.2 for Ordering information of Auxiliary Contacts

Tools required: None

Installation: Auxiliary Contact block is located on the top plate. Slots 1-3 and 5 are to be used for mounting 4 auxiliary contact blocks. 4th slot is designated for routing control wires and 6th slot carries additional auxiliary contact for shunt release circuit.

Click-fit the Auxiliary contact assembly in the specific slots on Top plate as shown.

While making connections, refer wiring diagrams on pages 3-38 to 3-44 in this manual. Use NO/NC contact numbers as specified in the wiring diagram and NOT on the auxiliary contact units.

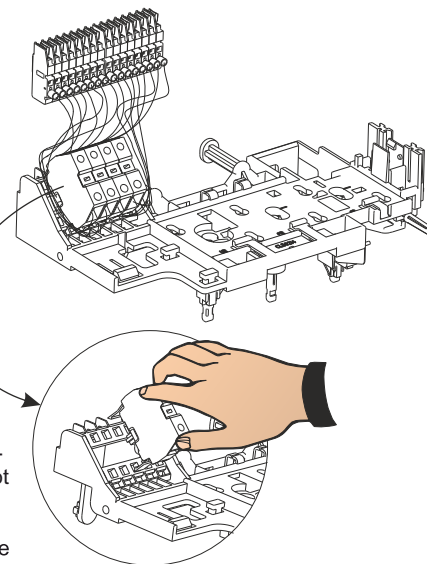

b. Shunt Release - SR :

Function: To trip the breaker from a remote location

Features: Available with the following control voltages,

Type	Normal Voltage	Short-time Power Consumption	Operating Limit
SR	110, 220, 240, 415 Vac 50/60Hz	200 VA 0.5s	70-110%
	24, 30, 48, 60, 110, 125/127, 220, 250 Vdc		

Refer section 7.2 for ordering information of Shunt release.

Shunt Release (SR) has the widest band of operation from 10% to 130%. This allows tripping of breaker, even in case of a substantial dip in control supply voltage.

Tools required: None

Installation: Drop fit the Shunt release in the assigned slot and slide backwards to lock. Also, fix the pre-wired Auxiliary Contact Block.

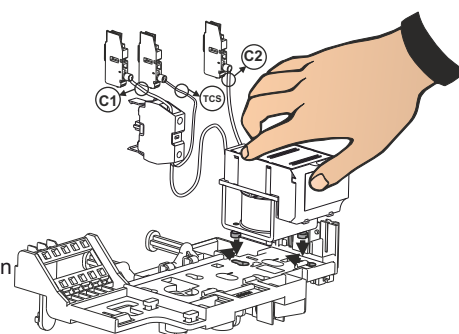

c. Closing Release - CR :

Function: To remotely close the breaker.

Features: Closing releases are available with the following control voltages,

Normal Voltage	Short-time Power Consumption	Operating Limit
110, 220, 240, 415 Vac 50/60Hz	200 VA max. 0.5s	85 - 110 %
24, 30, 48, 60, 110, 125/127, 220, 250 Vdc		

Refer section 7.2 for ordering information of Closing release.

Closing Release consists of an Electronic circuit to ensure no watt loss, inspite of continuous power supply, thus saving energy.

Tools required: None

Installation: Drop fit the Closing release in the assigned slot and slide backwards to lock.

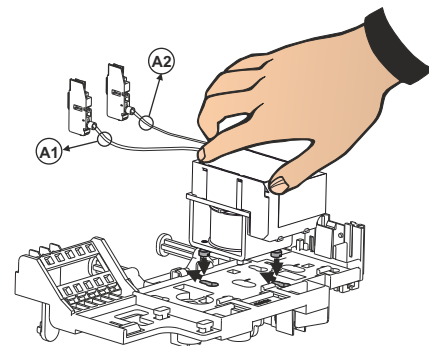

d. Undervoltage Release UVR :

Function: To trip the breaker in case of system voltage drop.

Features: Undervoltage releases are available with the following control voltages,

Type	Normal Voltage	Short-time Power Consumption	Operating Limit
UVR (Delay Setting-0, 1, 3 & 5 sec)	110, 240, 415 Vac 50Hz	200 VA max., 3s	85 - 110%
	110, 220, 240, 415 Vac 60Hz		
	24, 30, 48, 110, 220 Vdc		

Refer section 7.2 for ordering information of Undervoltage release.

Undervoltage Release also employs Electronic circuit to save energy.

Tools required: None

Installation: Drop fit the Undervoltage release in the assigned slot and slide backwards to lock. Similarly, click-fit the U/V controller (4c) as shown.

Breakers equipped with Undervoltage release cannot be normally closed unless the release is energized.

In case of Undervoltage release, the release can be defeated by pressing the latch as shown in adjoining diagram. This enables breaker closing, even without control supply.

To return the release to normal state, energize the release and then disconnect the control supply.

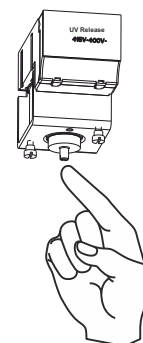
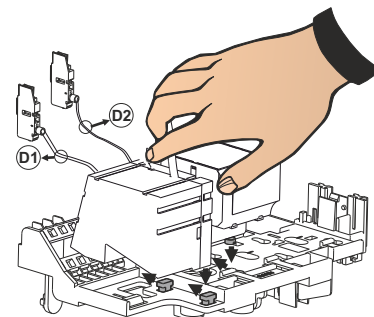

e. Electrical Charging Device - ECD :

Function: To charge the main spring electrically.

Features: A manually charged breaker can be converted to Electrical charging on site, by fixing the Electrical Charging Device.

ECD is available with the following supply voltages,

Rated Voltage	Power Consumption	Operating Range
110, 220, 240, 415 Vac 50/60Hz	300 VA max,	85 - 110 %
24, 30, 48, 60, 110, 125, 200, 250 Vdc		

Refer section 7.2 for ordering information of Electrical Charging Device.

Tools required: Allen key (5 mm)

Installation: On the ECD, turn the output shaft in anti-clockwise direction till the slot is aligned with corresponding position of charging shaft.

At this position, engage the output shaft of the ECD with charging shaft of the breaker. Fix ECD on the breaker using 2 allen screws at positions indicated by arrows.

CAUTION To avoid possibility of personal injury, ensure that before opening the face, breaker is OFF and Spring is discharged.

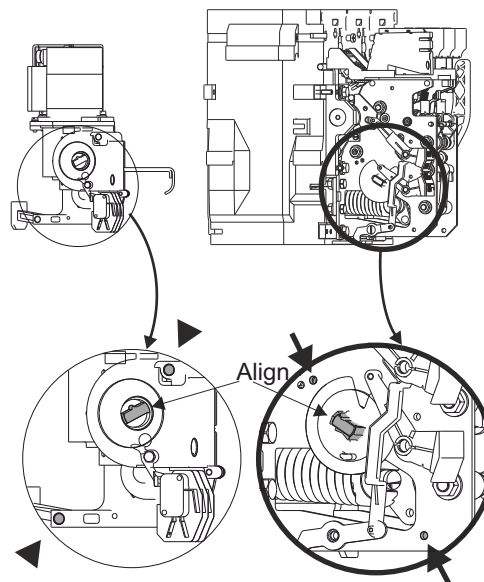

f. Operation Counter :

Function: Operation counter counts number of cycles operation seen by the breaker.

Tools required: None

Installation:

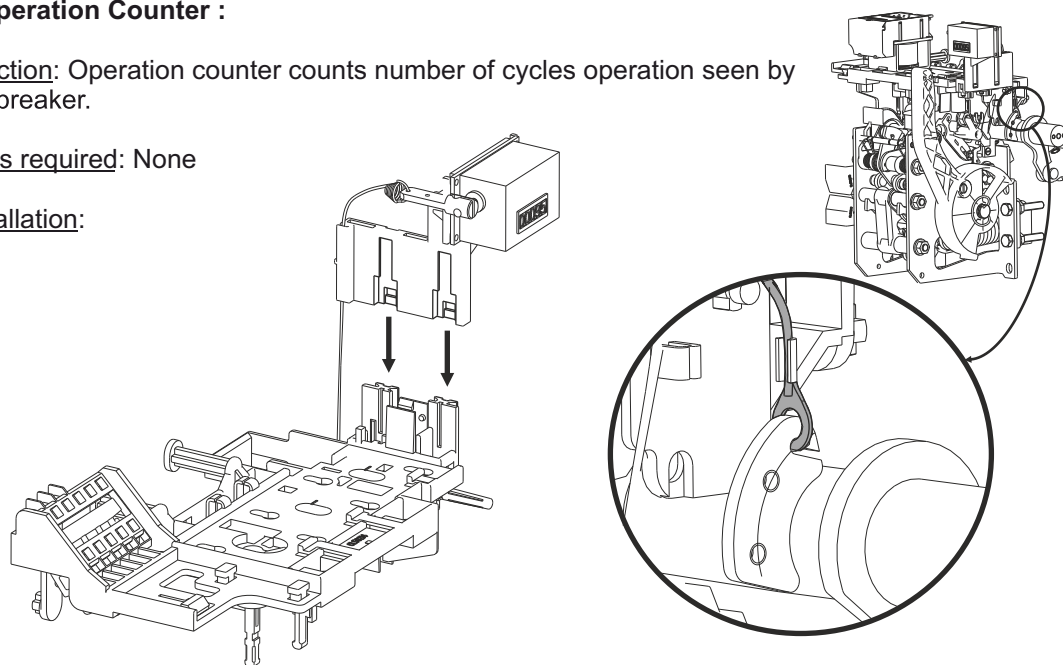

Click-fit the operational counter on the top plate.

Hook the counter lug to the main shaft.

g. Common Fault Indication:

Function: To provide electrical indication of ACB tripping due to Protection & Control Unit.

Tools required: None

Installation: Click fit the assembly as shown

When 'Auto Reset' is installed, the Common Fault indication will reset automatically.

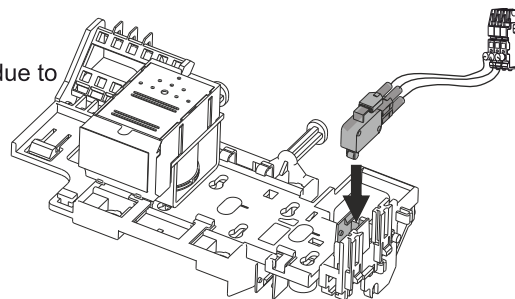

h. Undervoltage & Shunt release Trip Indication:

Function: To provide electrical indication of tripping due to Undervoltage release and Shunt release respectively.

Tools required: Screw driver (Tip width 8 mm) or Philip head (Tip No. 2)

Installation:

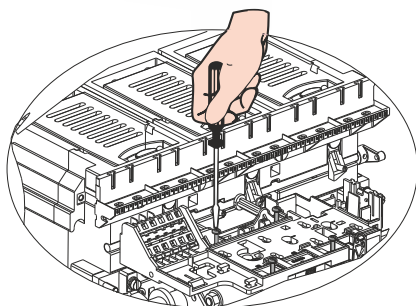

1. Remove Top plate by removing 4 screws as shown

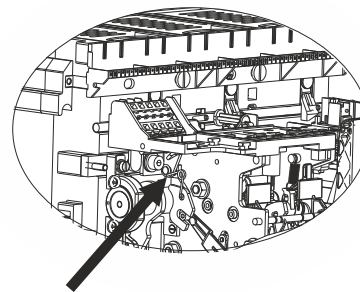

2. Delatch Top-plate from spring

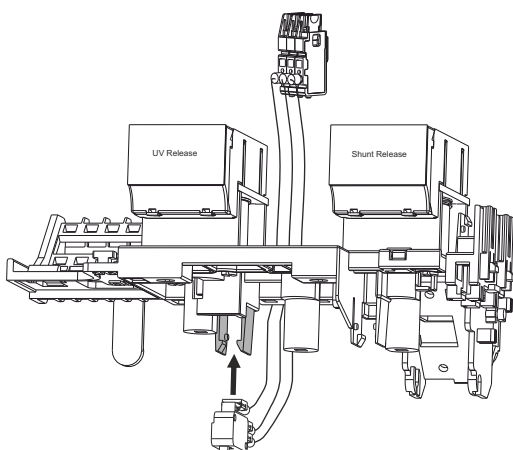

Click-fit Undervoltage release trip indication assembly as shown

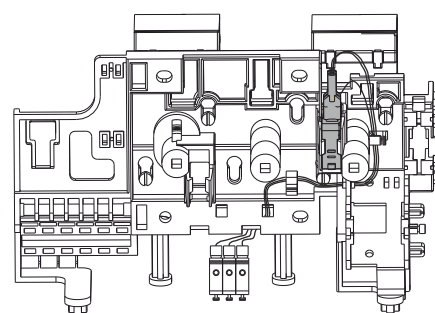

Top-plate as seen from bottom

Click-fit Shunt release Trip Indication assembly and route connecting wires as shown

After fixing accessories:

Accessories (a-e & g-h)

The above accessories (except F) are pre-wired with Secondary Isolating Contacts (8b) to be fixed on breaker. SIC positions are printed on the connecting wires and SIC bridge.

Tools required: None

Installation: Click-fit the breaker SICs in the respective positions on the SIC bridge.

Also fix the cradle SIC block with screw at corresponding positions.

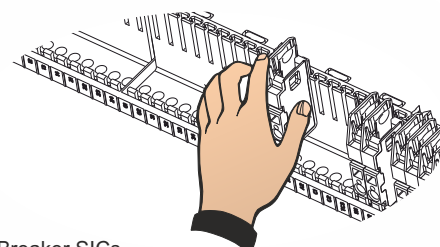

Fixing Breaker SICs

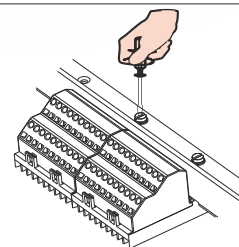

Fixing Cradle SICs

Accessories (a-f)

After fixing the above accessories, push out the corresponding opaque plug on the fascia from inside and plug-in the transparent plug from outside.

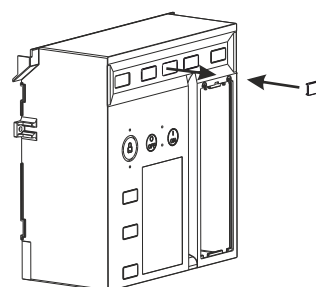

i. Shroud for ON-OFF Buttons (11):

Function: To prevent unauthorized access to ON & OFF buttons.

Features: Push button cover enables padlocking and sealing of ON/OFF buttons together or independently.

Tools required: Screw Driver (Tip width 3 mm)

Installation: For fitting the Push button cover, drill 2 holes of 3 mm diameter in the fascia at positions indicated and fix the push button cover using 2 screws.

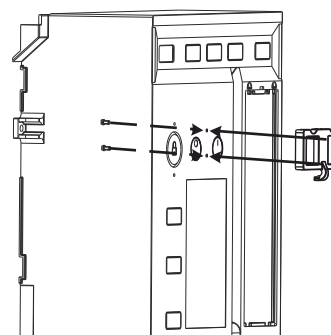









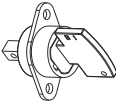

j. Locking 'OFF' Button (18):

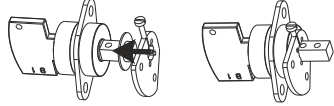
Function: To prevent undesirable Closing of breaker.

Features: It can accept Kirk/Castell/Profalux/Ronis locks for interlocking with other electrical devices in the control scheme.

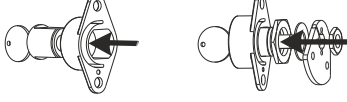
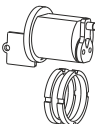
Tools required: Screw Driver (Tip width 3 mm)

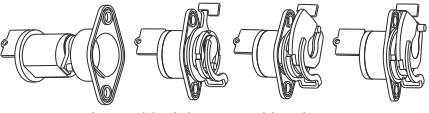
Installation:

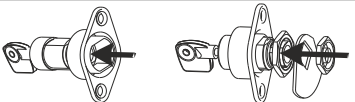
Lock Type	Lock	Components for 'Locking Arrangement'			Assembly on the Lock
		Actuator	Lock plate	Adaptors & Plugs	
Castell					 Assemble hardware on the Lock and tighten screw
Ronis					 Assemble Adaptor and hardware
Kirk					 Assemble Adaptor and hardware
Profalux					 Assemble Adaptor and hardware

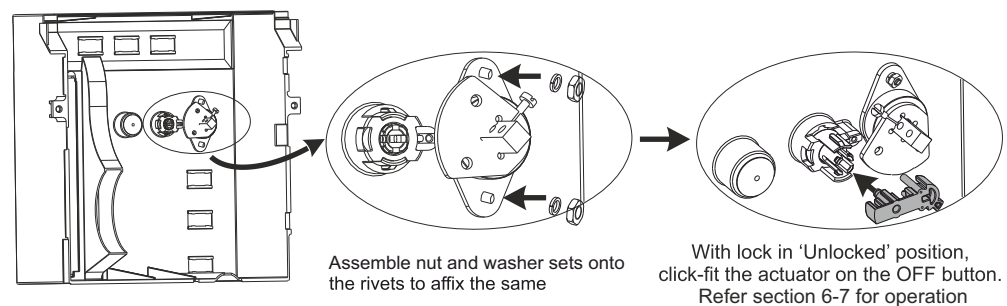
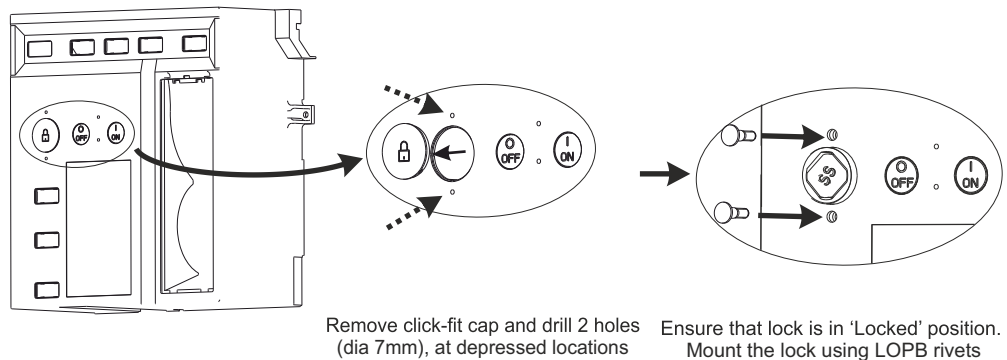

Section 5

Protection & Control units

5.1 Identification

5.2 Protection Characteristics

5.1 Identification

BU-BTX 1.0

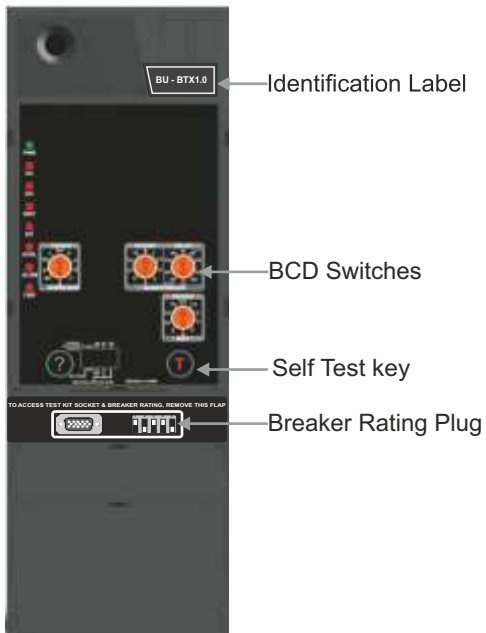

BU-BTX 1G

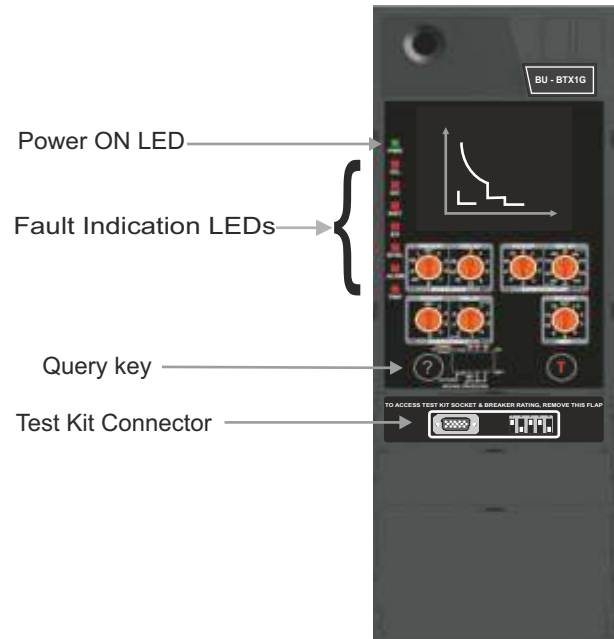

BU-BTX 1.5G



BU-BTX 1Gi

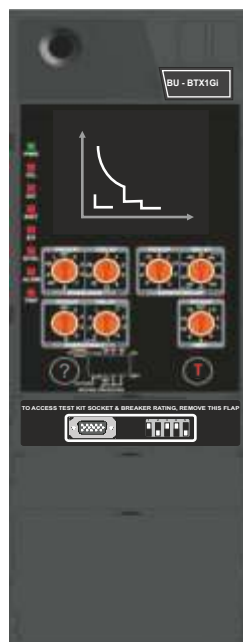

BU-BTX 1.5Gi



5.1 Identification

BU-BTX 3.5

BU-BTX 3.5EC

BU-BTX 3.5H

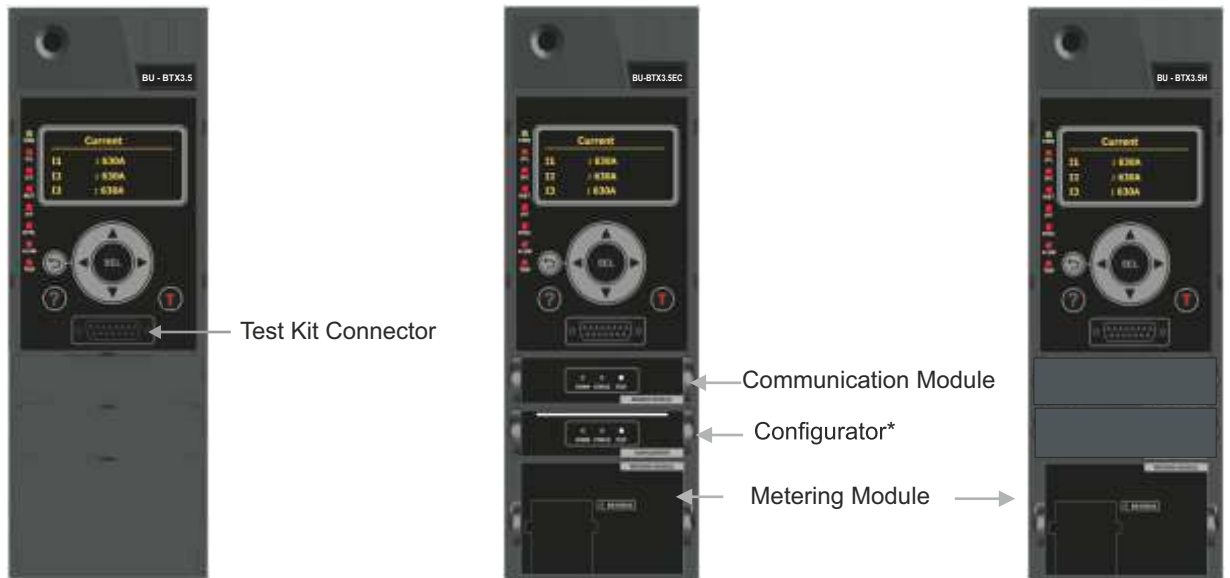

* Available as accessory

2.Feature List

Feature no.	FEATURES/MODULE SUPPORTED	BU-BTX VERSIONS						
		1.0	1G	1Gi	1.5G	1.5Gi	3.5	3.5EC
1	Protections	LSI	LSIGN		LSIGN	LSIGN	LSIGN	LSIGN
2	Current Metering				✓	✓	✓	✓
3	Voltage Metering					*	✓	✓
4	THD & I-harmonics Metering							✓
5	Trip records					✓	✓	✓
6	Event records					✓	✓	✓
7	Additional protections					✓	✓	✓
8	Power Metering					*	✓	✓
9	Maximum Demand					*	✓	✓
10	Reverse Power					*	✓	✓
11	Trip Circuit Supervision					*	*	*
12	Earth Leakage					*	*	*
13	Restricted Earth Fault					*	*	*
14	Digital Input Output					*	*	*
15	Analog Output					*	*	*
16	Relay					*	*	*
17	Zone Selective Interlock			✓		✓	*	*
18	Configurator (Smart Card)					*	*	*
19	Temperature Module					*	*	*
20	Modbus					*	✓	*
21	Profibus					*	*	*
22	Zig-bee					*	*	*

Metering display of BU-BTX1.5G/1.5Gi/3.5/3.5EC/3.5H P&C Unit

Parameter	Screen abbreviation	Details
Current ~	I1,I2,I3,	Phase
	In,Ig	Neutral and Earth
	IΔ, IREF	Earth Leakage,Restricted EF Current
	I _{max}	Maximum running current per phase
	% Load	Percentage Loading per phase
	Avg.I	Average phase current
	**THD current %	R, Y, B -Phase THD metering
**I1, I2, I3 harmonics	Upto 13th harmonic	
Voltage #	V1,V2,V3	Phase-Neutral voltage
	Max V	Maximum voltage per phase
	V12,V23,V31	Ph-Ph Voltage
	Max V12,V23,V31	Maximum Ph-Ph Voltage
	Avg. Vp-p	Average Ph-Ph Voltage
	Avg Vp-n	Average Ph-N Voltage
	**THD voltage %	R, Y, B -Phase THD metering
**V1, V2, V3 harmonics	Upto 13th harmonic	
Frequency #	F	System Frequency
Power Factor #	P.F.	System Power Factor
Power #	W	Active Power per phase and total (kW)
	VAr	Reactive Power per phase and total (kVAr)
	VA	Apparent Power per phase and total (kVA)
Energy #	Wh	Active Energy per phase and total (kWh)
	VArh	Reactive Energy per phase and total (kVArh)
	VAh	Apparent Energy per phase and total (kVAh)
Max Demand #	Wh	Active Energy (kWh)
	VArh	Reactive Energy (kVArh)
	VAh	Apparent Energy (kVAh)
Temperature ^	∅	Temperature per phase (°C)

~ BU-BTX1.5G,1.5Gi gives only I1, I2, I3, In, Ig current metering.
 * Features/Modules available as optional
 # Requires Metering module
 ^ Requires TM Module.
 ** only in BU-BTX3.5H

5.3 Detailed Overview



Protection Settings for BU-BTX1.0/1G/1Gi/1.5G/1.5Gi

Parameter		BTX1.0	BTX1.0G	BTX1.5G	BTX1Gi	BTX1.5Gi	Factory Settings
Overload (Phase)	Protection: Enable/Disable	✓	✓	✓	✓	✓	Enable
	Pick-Up (I _r)=I _n x...for I2T	OFF- 0.4-0.5-0.6-0.7-0.8-0.85-0.9-0.95-1					1
	Delay (tr) in s	10	0.5-1-2-4-6-12-18-24-30				12
	Pre-alarm	0.9I _r (fixed)					-
	Thermal Memory ON/OFF	✓	✓	✓	✓	✓	OFF
Overload (Neutral)	Protection: Enable/Disable	-	✓	✓	✓	✓	Disable
	Pick-Up I _n = I _r x...	-	50%-100%-150%-200%			50%	
	Pre-alarm	-	0.8I _n (fixed)				-
	Delay (tr) in s	-	Same as Overload Phase				-
Short Circuit	Protection: Enable/Disable	x	x	x	x	x	Enable
	I2T ON/OFF	✓	✓	✓	✓	✓	OFF
	Pick-Up I _s = I _n x...	0.6-1-1.5-2-3-4-6-8-10-12					6In
	Delay (ts)	20-100-200-300-400 ms					400ms
	Pre-alarm	0.5I _s (fixed)					-
Instantaneous	Protection: Enable/Disable	✓	✓	✓	✓	✓	Disable
	Pick-up (I _p)=I _n x...	OFF-1.5-2-3-4-6-8-10-12-15					10 I _n
Earth Fault	Protection: Enable/Disable	-	✓	✓	✓	✓	Enable
	I2T: ON/OFF	-	✓	✓	✓	✓	OFF
	Pick-Up(I _g)= I _n x...	-	OFF-0.2-0.3-0.4-0.5-0.6				0.6I _n
	I2T OFF (tg)	-	0.1-0.2-0.3-0.4-1				1
	I2T ON (tg)	-	0.1-0.2-0.3-0.4				-
	Pre-alarm	-	0.8I _g (fixed)				-
Inbuilt-ZSI	Short Circuit Enable/Disable	-	-	-	✓	✓	Disable
	Earth Fault Enable/Disable	-	-	-	✓	✓	Disable

Breaker Rating Plug Settings for BU-BTX1.0/1G/1Gi/1.5G/1.5Gi

BREAKER RATING	DIP SWITCH REPRESENTATION	In SETTING		I-FRAME SETTING			
		1	2	3	4	5	
400		↓	↓	↓	↓	↓	800
630		↓	↑	↓	↓	↓	
800		↑	↓	↓	↓	↓	
1000		↓	↑	↓	↓	↑	1600
1250		↓	↑	↓	↓	↑	
1600		↑	↓	↓	↓	↑	
2000		↓	↓	↓	↑	↓	3200
2500		↓	↑	↓	↑	↓	
3200		↑	↓	↓	↑	↓	
2000		↓	↓	↓	↑	↑	4000
2500		↓	↑	↓	↑	↑	
3200		↑	↓	↓	↑	↑	
4000		↑	↑	↓	↑	↑	
5000		↓	↓	↑	↓	↓	6300
6300		↓	↑	↑	↓	↓	

Note: ↑ This symbol indicates that DIP Switch is ON and ↓ indicates that DIP Switch is OFF.

CAUTION

Mismatch between actual breaker rating and setting on the P&C unit will result in error in Protection Parameters & current measurement displayed .

Protection Settings for BU-BTX 3.5/3.5EC/3.5H



Parameter		BU-BTX3.5	BU-BTX3.5EC	BU-BTX3.5H	Factory Settings
Overload (Phase)	Protection: Enable/Disable	⊗	⊗	⊗	Enable
	Pick-Up (Ir)=In x... for I ² T, I ⁴ T, SI, LI/VI Curves	0.4 to 1 In in steps of 0.05			1 (I ²)
	Delay (tr) in s	0.5-1-2-4-6-12-18-24-30			12
	Pre-alarm	0.5 to 0.95 in steps of 0.05xlr			0.5lr
	Thermal Memory ON/OFF	⊗	⊗	⊗	ON
Overload (Neutral)	Protection: Enable/Disable	⊗	⊗	⊗	Disable
	Pick-Up In= Ir x5 to 2 in steps of .5			Disable
	Pre-alarm	.5 to .95 in steps of .05xlr			-
	Delay (tr) in s	Same as Overload Phase			-
	Thermal Memory ON/OFF	⊗	⊗	⊗	OFF
Short Circuit	Protection: Enable/Disable	⊗	⊗	⊗	Enable
	Double S/C ON/OFF	⊗	⊗	⊗	OFF
	I ² T ON/OFF	⊗	⊗	⊗	OFF
	Pick-Up Lo, Is= In x ...	0.6 to 12 In in steps of 0.05			6 In
	Pick-Up Hi, Is= In x ...	0.6 to 12 In in steps of 0.05			6 In
	Delay Hi (ts)	20-100-200-300-400 ms			400 ms
	Delay Lo (ts)	20-100-200-300-400 ms			400 ms
	Pre-alarm	0.5 to 0.95 in steps of 0.05xIs			0.5Is
	Cold Pick-Up: ON/OFF	⊗	⊗	⊗	OFF
	Cold Delay	100 ms to 10s in steps of 100ms			1 s
	Directional SC	Protection: Enable/Disable	⊗	⊗	⊗
	Direction: Top / Bottom	⊗	⊗	⊗	-
	I ² T: ON/OFF	⊗	⊗	⊗	-
	Pick-up (Is) : In x ...	0.6 to 12 In in steps of 0.05			-
	Delay (ts)	20-100-200-300-400 ms			-
	Pre-alarm	0.5 to 0.95 in steps of 0.05xIs			-
	Cold Pick - Up: ON/OFF	⊗	⊗	⊗	-
	Cold Delay	100 ms to 10s in steps of 0.05xIs			-
Instantaneous	Protection: Enable/Disable	⊗	⊗	⊗	Enable
	Pick-up (Ip)=In x ...	1.5 to 10 in steps of 0.1 ; 10 to 15 in steps of 1			10 In
Earth Fault	Protection: Enable/Disable	⊗	⊗	⊗	Disable
	I ² T: ON/OFF	⊗	⊗	⊗	-
	Pick-Up (I _g)= In x ...	0.2-0.3-0.4-0.5-0.6			-
	I ² T OFF (tg)	100ms to 1 s in steps of 100 ms			-
	I ² T ON (tg)	100-200-300-400 ms			-
	Pre-alarm	0.5 to 0.95 in steps of 0.05xI _g			-
	Cold Pick-Up: ON/OFF	⊗	⊗	⊗	-
	Cold Delay	100ms to 5 s in steps of 0.1s			-
	Mode: Trip/Alarm/Both	⊗	⊗	⊗	-
	Restricted EF	Protection: Enable/Disable	⊗	⊗	⊗
	I ² T: OFF/ON	⊗	⊗	⊗	-
	Pick-Up (I _g) = In x ...	0.1 to 0.6 in steps of 0.1			-
	I ² T OFF (tg)	100 ms to 5 s in steps of 0.1s			-
	I ² T ON (tg)	100-200-300-400 ms			-
	Pre-alarm	0.5 to 0.95 in steps of 0.05xI _g			-
	Cold pick-Up: ON/OFF	⊗	⊗	⊗	-
	Mode: trip/Alarm/Both	⊗	⊗	⊗	-
Earth Leakage	Protection: Enable/Disable	⊗	⊗	⊗	Disable
	Pick-Up (I _Δ)	0.3 to 30A in steps of 0.1 A			-
	Delay	100-200-300-400-500 ms			-
	Mode: Trip/Alarm/Both	⊗	⊗	⊗	-
Under Current	Protection: Enable/Disable	⊗	⊗	⊗	Disable
	Pick-Up = Ir x ...	0.2 to 0.8 in steps of 0.05			-
	Delay	1 to 255 s in steps of 1 s			-
	Mode: Trip/Alarm/Both	⊗	⊗	⊗	-
Current Unbalance	Protection: Enable/Disable	⊗	⊗	⊗	Disable
	Pick-Up = In x ...	10 to 97% in steps of 5%			-
	Delay	500 ms to 60s in steps of 0.5s			-
	Mode: Trip/Alarm/Both	⊗	⊗	⊗	-
Under Voltage	Protection: Enable/Disable	⊗	⊗	⊗	Disable
	Pick up (Vs) = Vn x ...	0.7 to 0.95 in steps of 0.01			-
	Delay	100 ms to 5s in steps of 100 ms			-
	Vs reset	1.01 to 1.04 xVs			-
	Mode: Trip/Alarm/Both	⊗	⊗	⊗	-

Parameter		BU-BTX3.5	BU-BTX3.5EC	BU-BTX3.5H	Factory Settings
Over Voltage	Protection: Enable/Disable	⊗	⊗	⊗	Disable
	Pick-Up(Vs)= Vn x...	1.05 to 1.5 Vn in steps of 0.01			-
	Delay	100ms to 5s in steps of 100ms			-
	Vs reset	0.95 to 0.99 Vs in steps of 0.01			-
Voltage Unbalance	Protection: Enable/Disable	⊗	⊗	⊗	Disable
	Pick-Up (Vs) = Vn x...	5 to 20% in step of 1%			-
	Delay	500ms to 60 s in steps of 0.5s			-
	Vs reset	0.95 to 0.99 Vs in steps of 0.01			-
Residual Voltage	Mode: Trip/Alarm/Both	⊗	⊗	⊗	-
	Protection: Enable/Disable	⊗	⊗	⊗	Disable
	Pick-Up(Vs)=Vn x...	0.15/0.2/0.25/0.3/0.4			-
	Delay	100ms to 5s in steps of 0.1s			-
Under Frequency	Vs reset	0.95 to 0.99 Vs in steps of 0.01			-
	Mode: Trip/Alarm/Both	⊗	⊗	⊗	-
	Protection: Enable/Disable	⊗	⊗	⊗	Disable
	Pick-Up (Fn)	45-50 Hz in steps of 0.1Hz			-
Over Frequency	Delay	1-30 s in steps of 0.1s			-
	Reset Freq	1.01 to 1.05 Fn in steps of 0.01			-
	Mode: Trip/Alarm/Both	⊗	⊗	⊗	-
	Protection: Enable/Disable	⊗	⊗	⊗	Disable
Rev Power	Pick-Up (Fn)	50-55 Hz in steps of 0.1 Hz			-
	Delay	1-30 s in steps of 0.1s			-
	Reset Freq	0.95 to 0.99 Fn in step of 0.01			-
	Mode: Trip/Alarm/Both	⊗	⊗	⊗	-
Leading PF	Protection: Enable/Disable	⊗	⊗	⊗	Disable
	Pick-Up = Pn x...	0.05 to 0.4 in steps of 0.01			-
	Delay	100ms-20s in steps of 0.1s			-
	Mode: trip/Alarm/Both	⊗	⊗	⊗	-
Lagging PF	Protection: Enable/Disable	⊗	⊗	⊗	Disable
	Pick-Up = Pf x...	0.5 to 0.99 in steps of 0.01			-
	Delay	1/2/3/4/5 s			-
	Mode: trip/Alarm/Both	⊗	⊗	⊗	-
MD Active	Protection: Enable/Disable	⊗	⊗	⊗	Disable
	Type	Deliver/Receive			-
	Pick-Up = En x...	0.4 to 1 in steps of 0.01			-
	Mode: Trip/Alarm/Both	⊗	⊗	⊗	-
MD Reactive	Protection: Enable/Disable	⊗	⊗	⊗	Disable
	Type	Deliver/Receive			-
	Pick-Up= En x...	0.4 to 1 in steps of 0.01			-
	Mode: Trip/Alarm/Both	⊗	⊗	⊗	-
MD Apparent	Protection: Enable/Disable	⊗	⊗	⊗	Disable
	Type	Deliver/Receive			-
	PickUp=En x...	0.4 to 1 in steps of 0.01			-
	Mode: Trip/Alarm/Both	⊗	⊗	⊗	-
Phase Sequence	Protection: Enable/Disable	⊗	⊗	⊗	Disable
	Delay	100ms to 5s in steps of 100ms			-
	Mode: Trip/Alarm/Both	⊗	⊗	⊗	-
Bkr Failure	Protection: Enable/Disable	⊗	⊗	⊗	Disable
	Delay	50 ms to 2 s in steps of 0.05 s			-
Trip Records	Last 5 Records	⊗	⊗	⊗	-
Display		OLED display			-
Communication Module	Modbus/Profibus/Zig-bee Modules	*	⊗	*	-
Query		⊗	⊗	⊗	-
Supplimentary Module	Relay,DIO,Analog,ZSI,EL,REF,TM,TCS	*	*	*	-
Time based set group		⊗	⊗	⊗	-
Test kit connectivity		⊗	⊗	⊗	-
AUX supply(24V DC)		⊗	⊗	⊗	-

Protection Characteristics



Overload I^2T (for BU-BTX1.0)

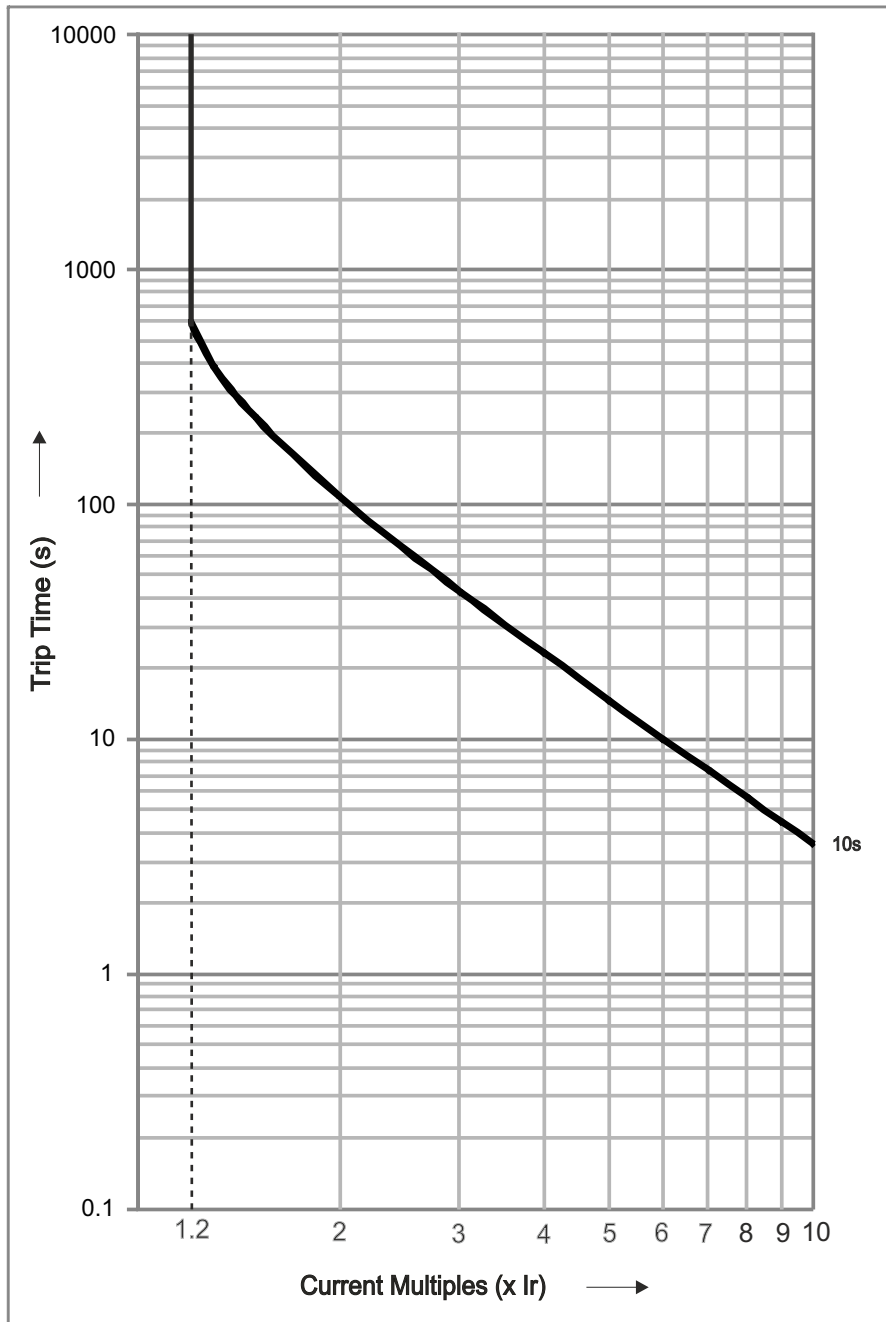

Tolerance
Trip Time: $\pm 20\%$

Protection Characteristics



Overload I^2T (for BU-BTX 1.0,1G,1Gi,1.5G,1.5Gi,3.5,3.5EC,3.5H)

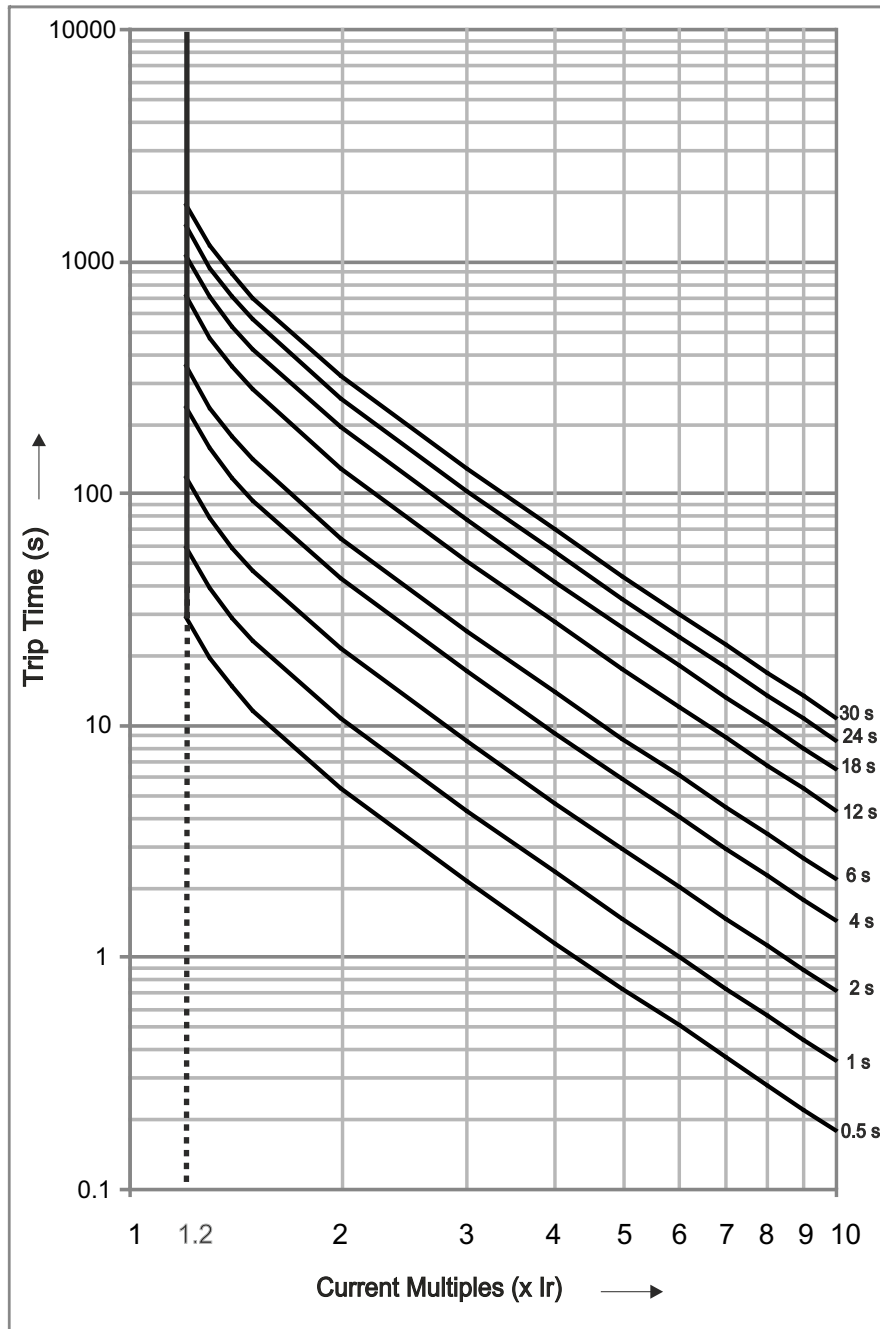

Tolerance
Trip Time: $\pm 20\%$

Protection Characteristics



Overload I^2T for (BU-BTX3.5/3.5EC/3.5H)

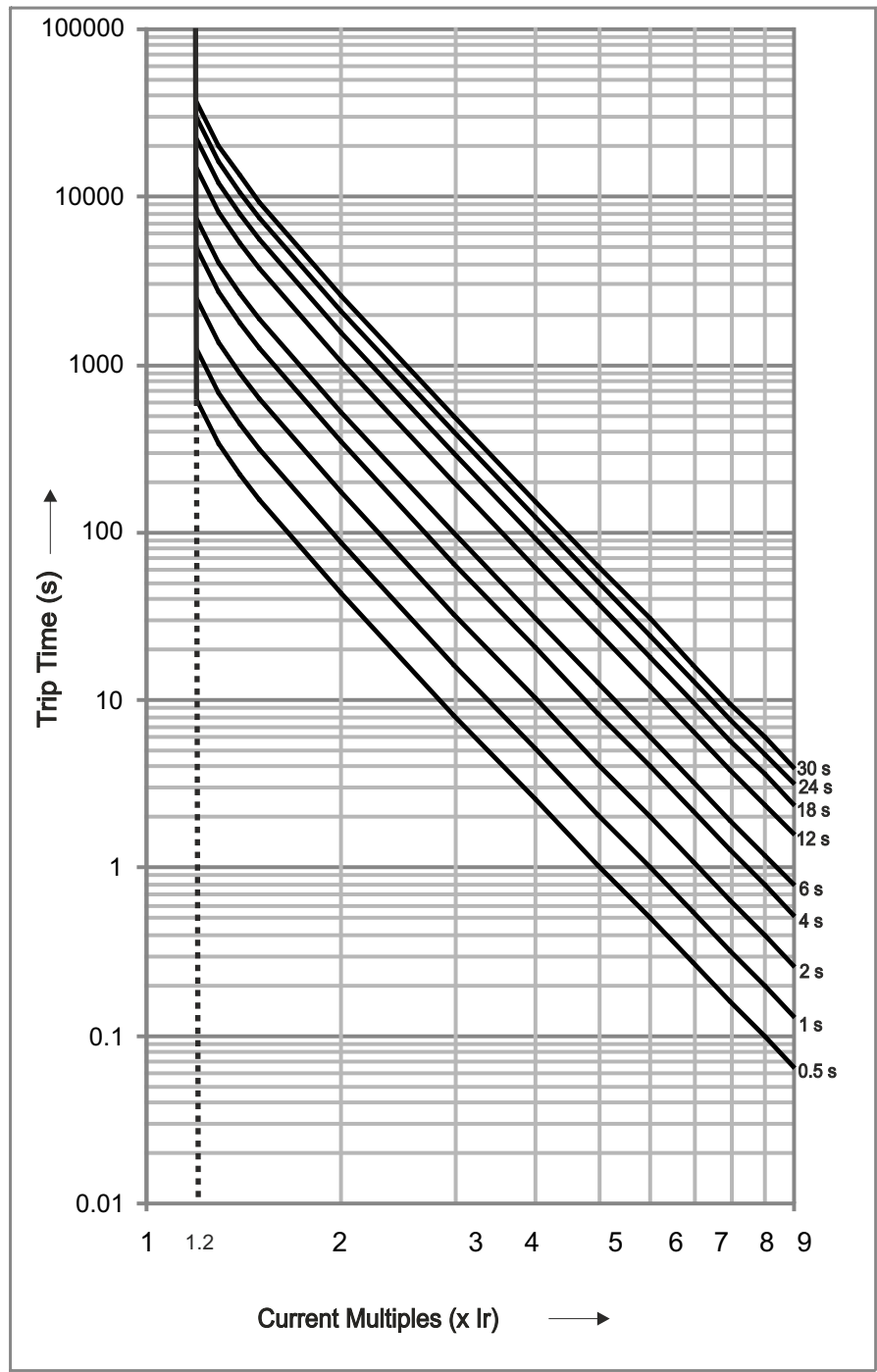

Tolerance
Trip Time: ±20%

Protection Characteristics



Overload SI (for BU-BTX3.5/3.5EC/3.5H)

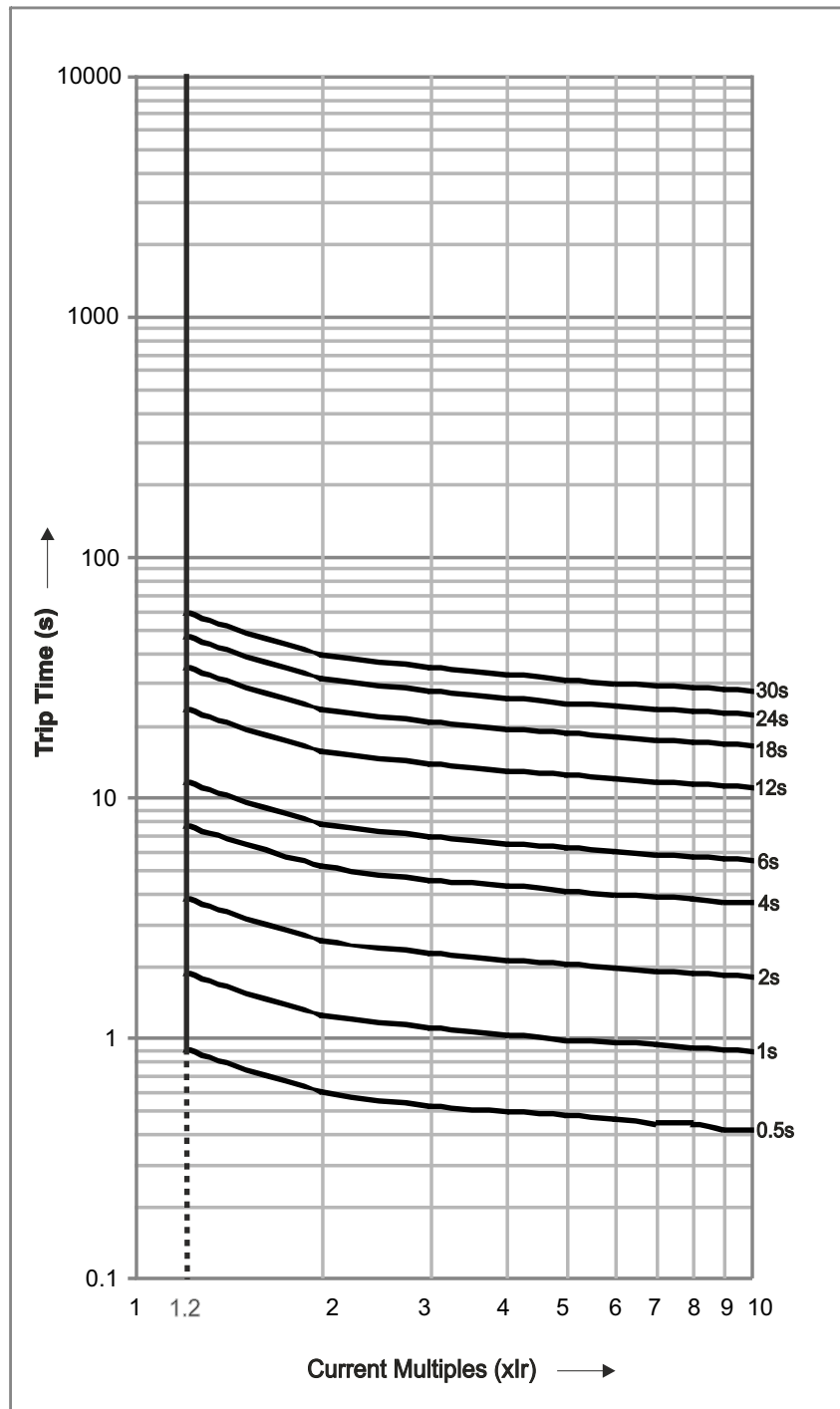

Protection Characteristics



Overload LI/VI(for BU-BTX/3.5/3.5EC/3.5H)

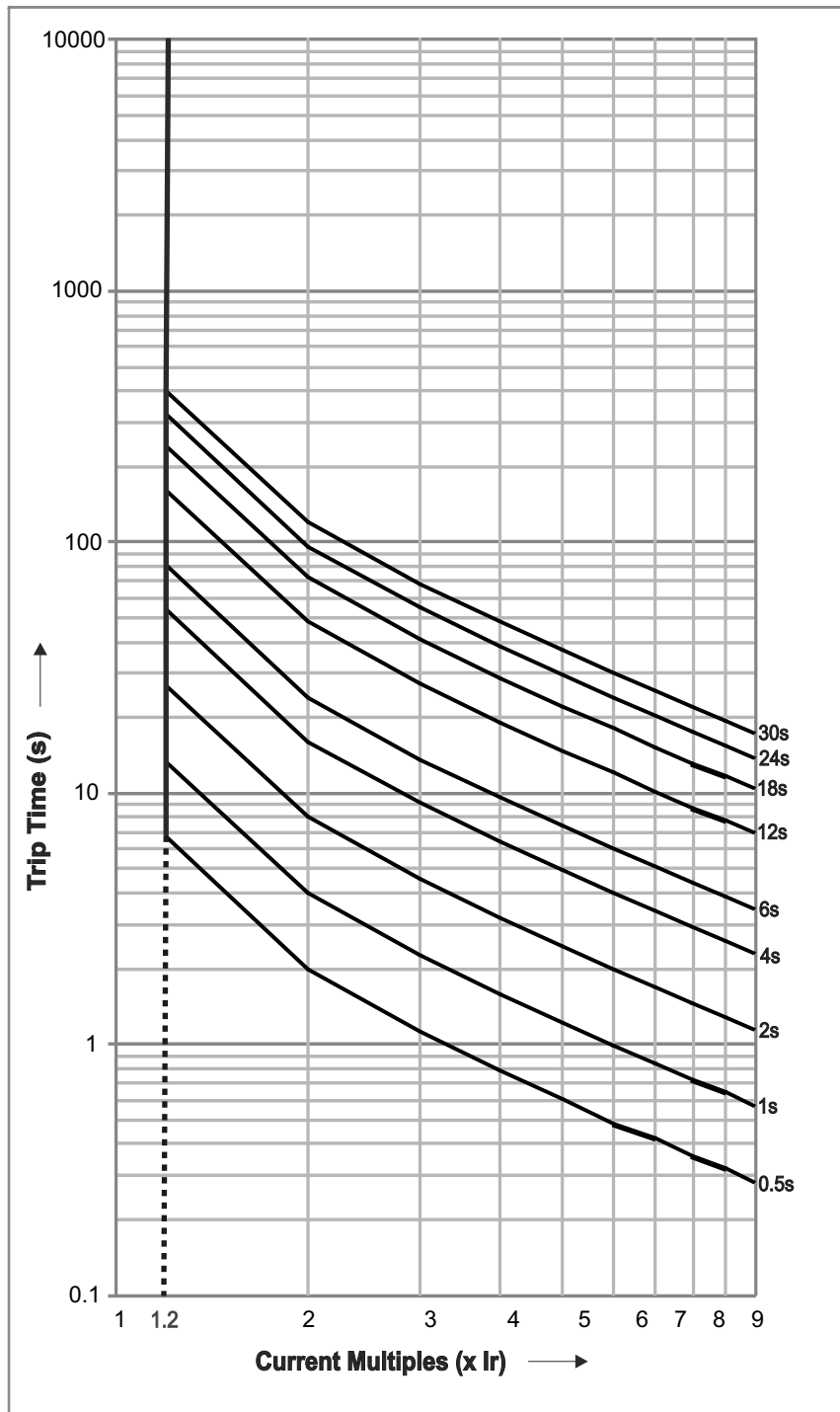

Tolerance
Trip Time: $\pm 20\%$

Protection Characteristics



Short Circuit I^2T ON(for BU-BTX1G/1.5G/1Gi/1.5Gi/3.5/3.5EC/3.5H)

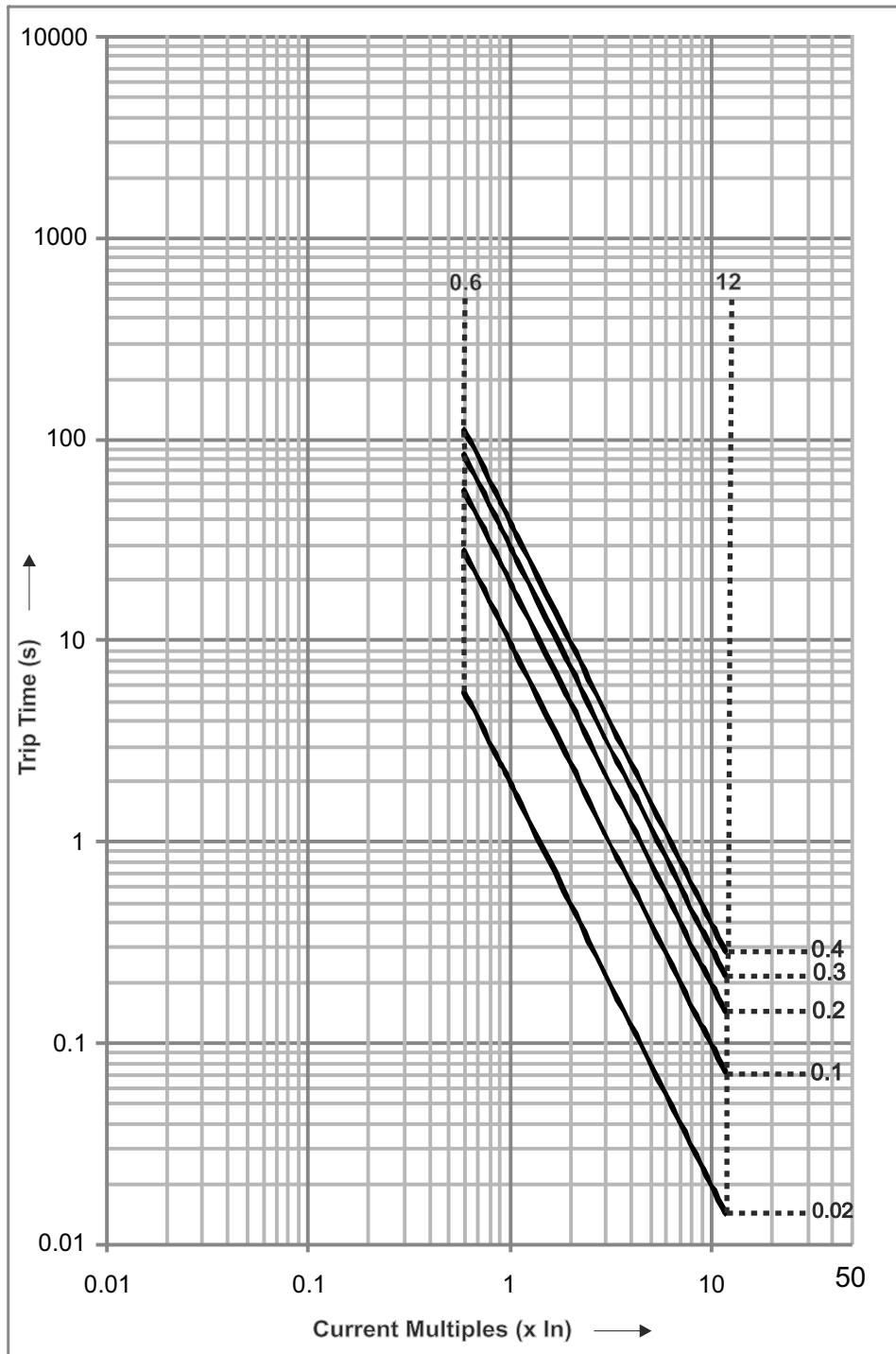

Protection Characteristics



Short Circuit I²T OFF (for BU-BTX1.0,1G,1Gi,1.5G,1.5Gi,3.5,3.5EC,3.5H)

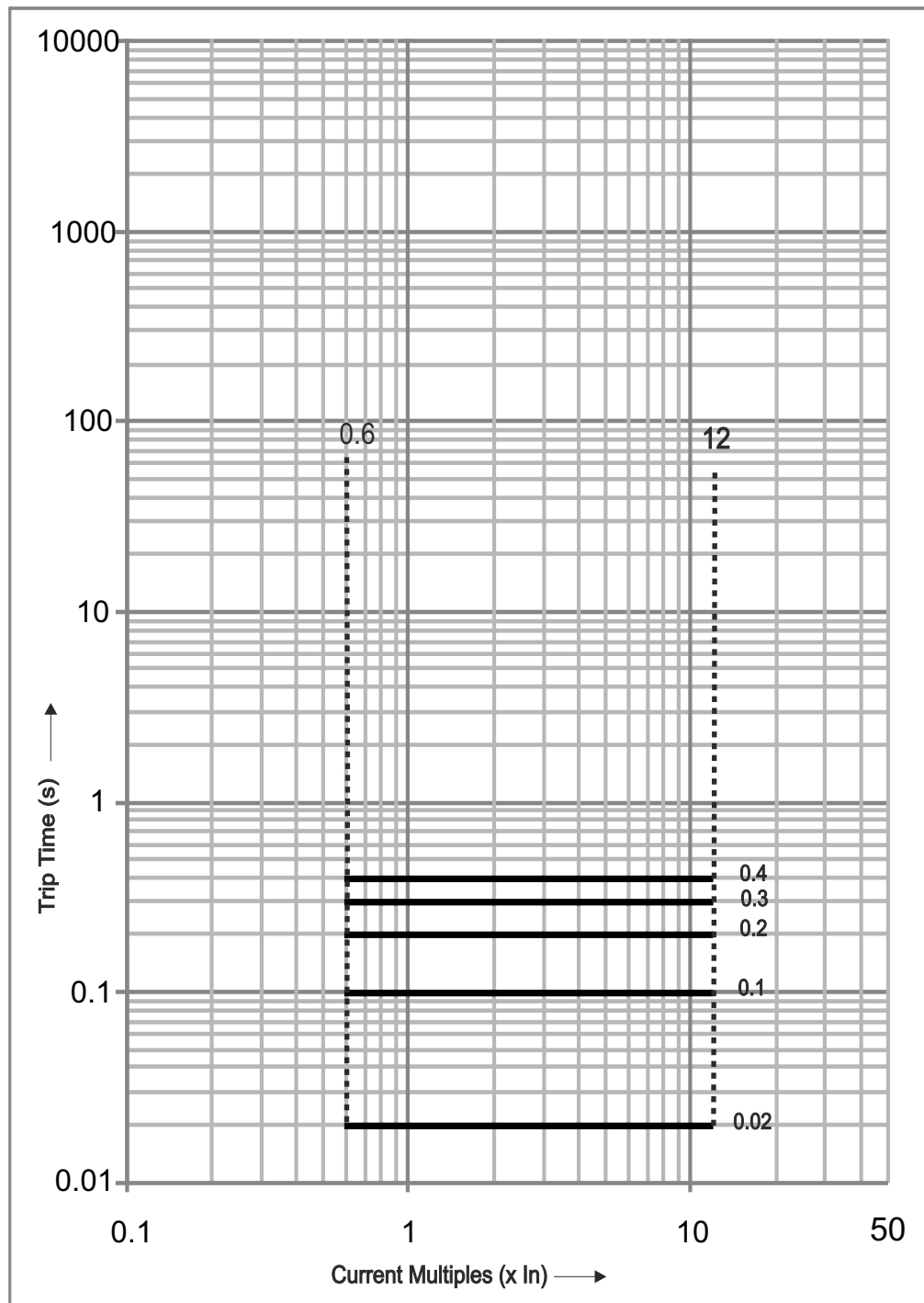

Protection Characteristics



Instantaneous (for BU-BTX1.0,1G,1Gi,1.5G,1.5Gi,3.5,3.5EC,3.5H)

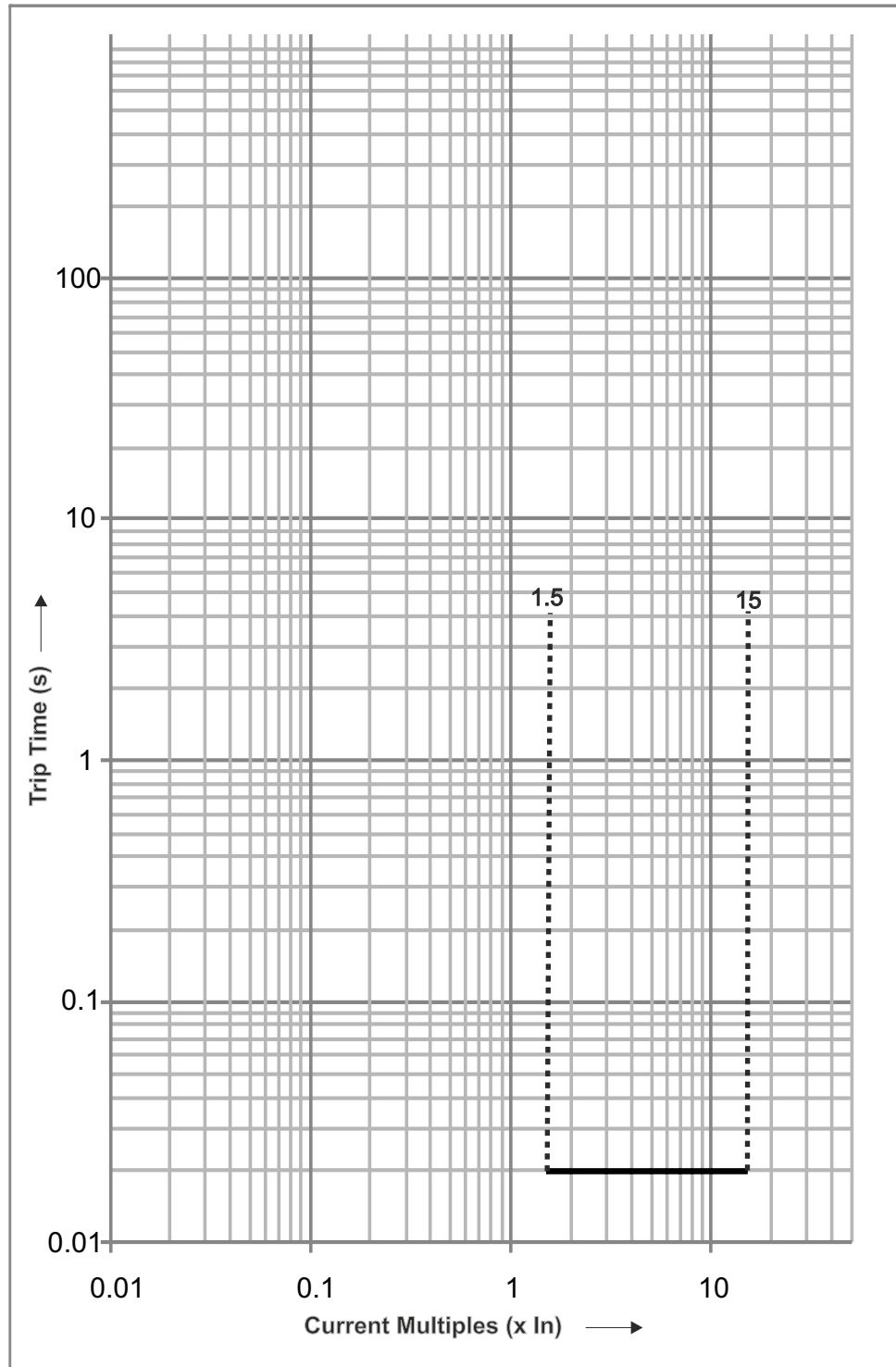

Protection Characteristics



Earth Fault I²T ON (for BU-BTX1G/1Gi/1.5G/1.5Gi)

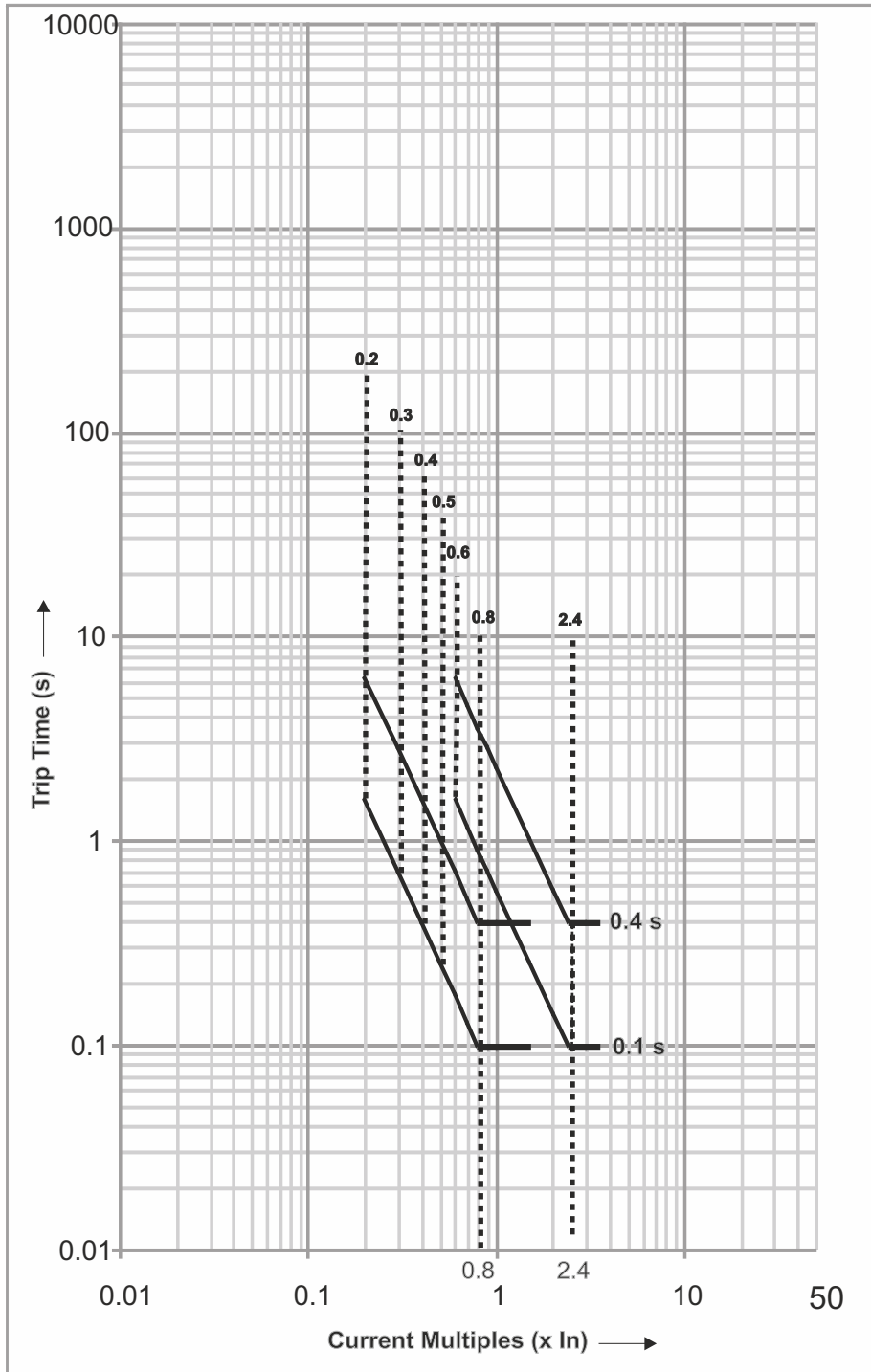

Protection Characteristics



Earth Fault I²T OFF (BU-BTX1G/1Gi/1.5G/1.5Gi)

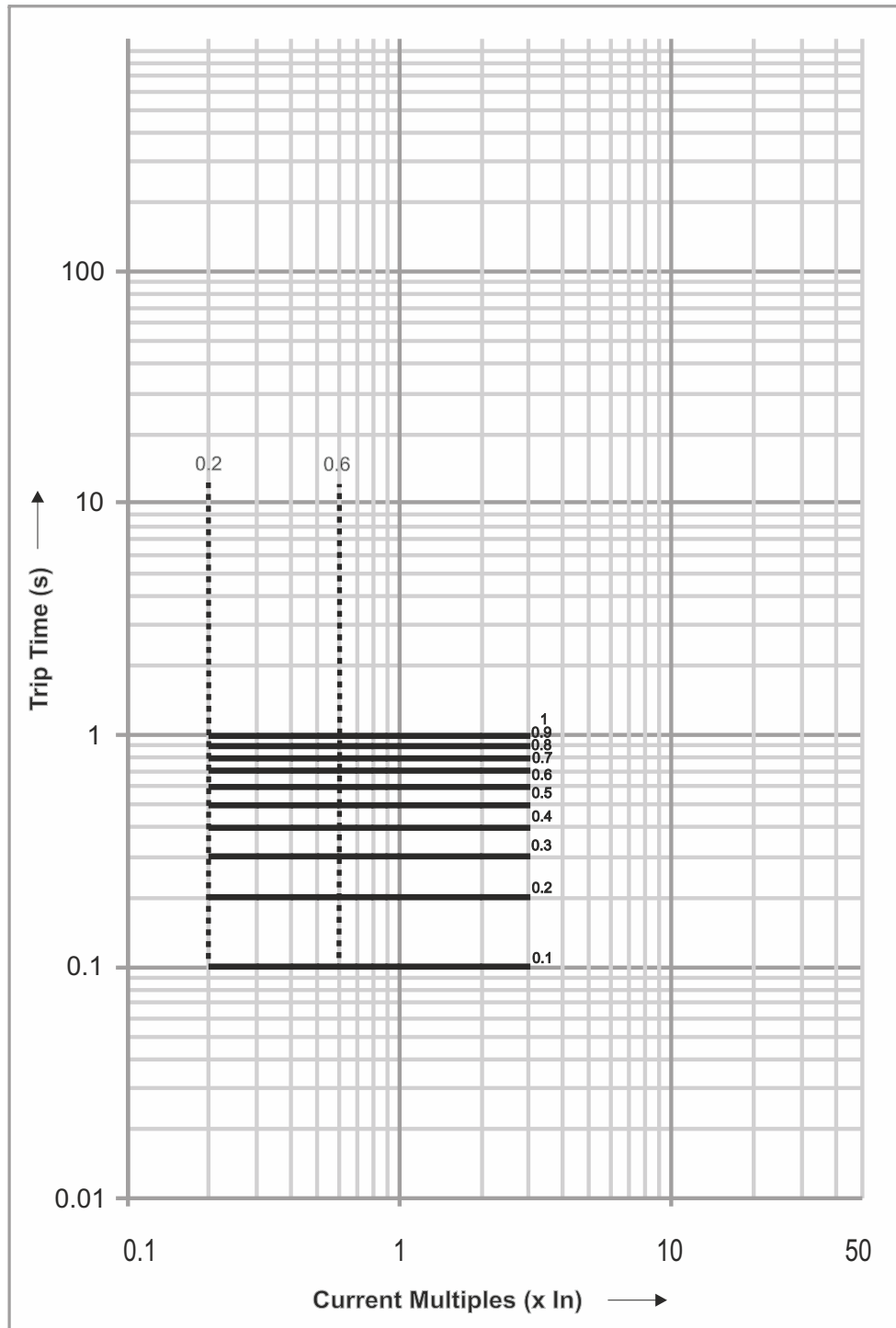

Protection Characteristics



Earth Fault I²T ON (for BU-BTX 3.5/3.5EC/3.5H)

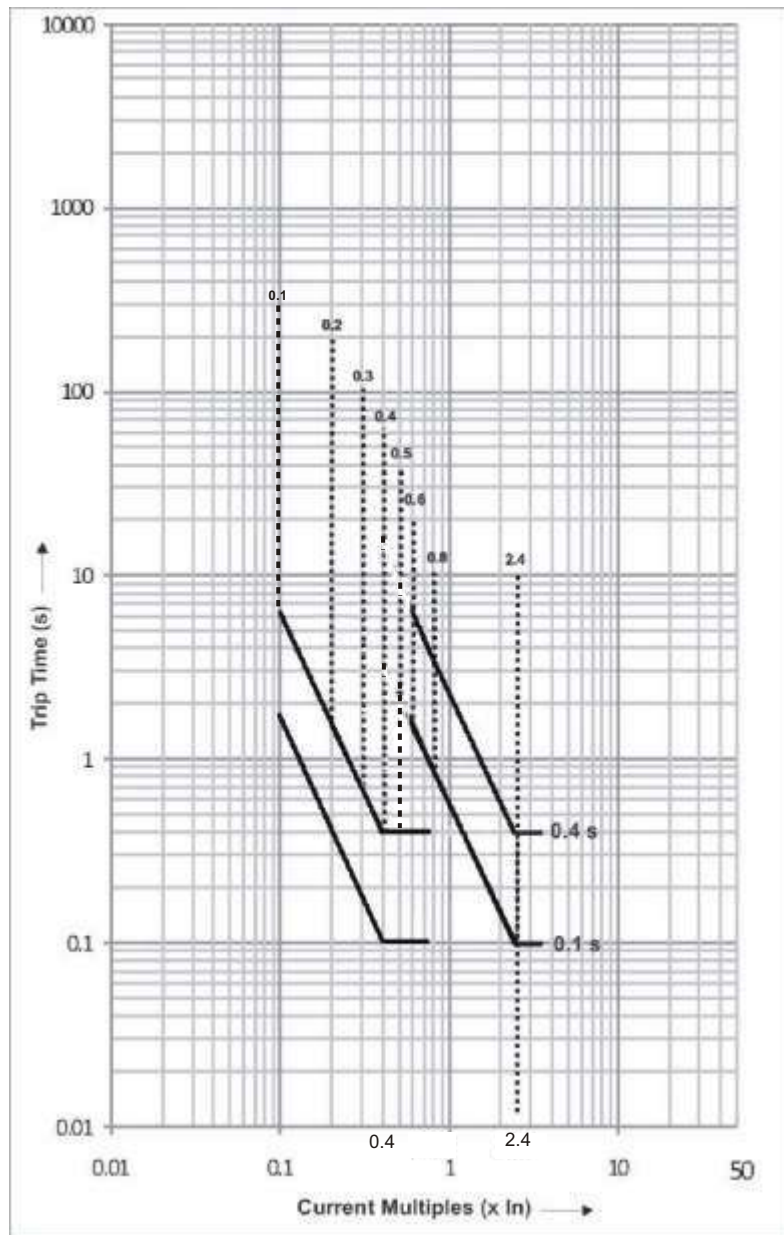

Protection Characteristics



Earth Fault I²T OFF (BU-BTX3.5/3.5EC/3.5H)

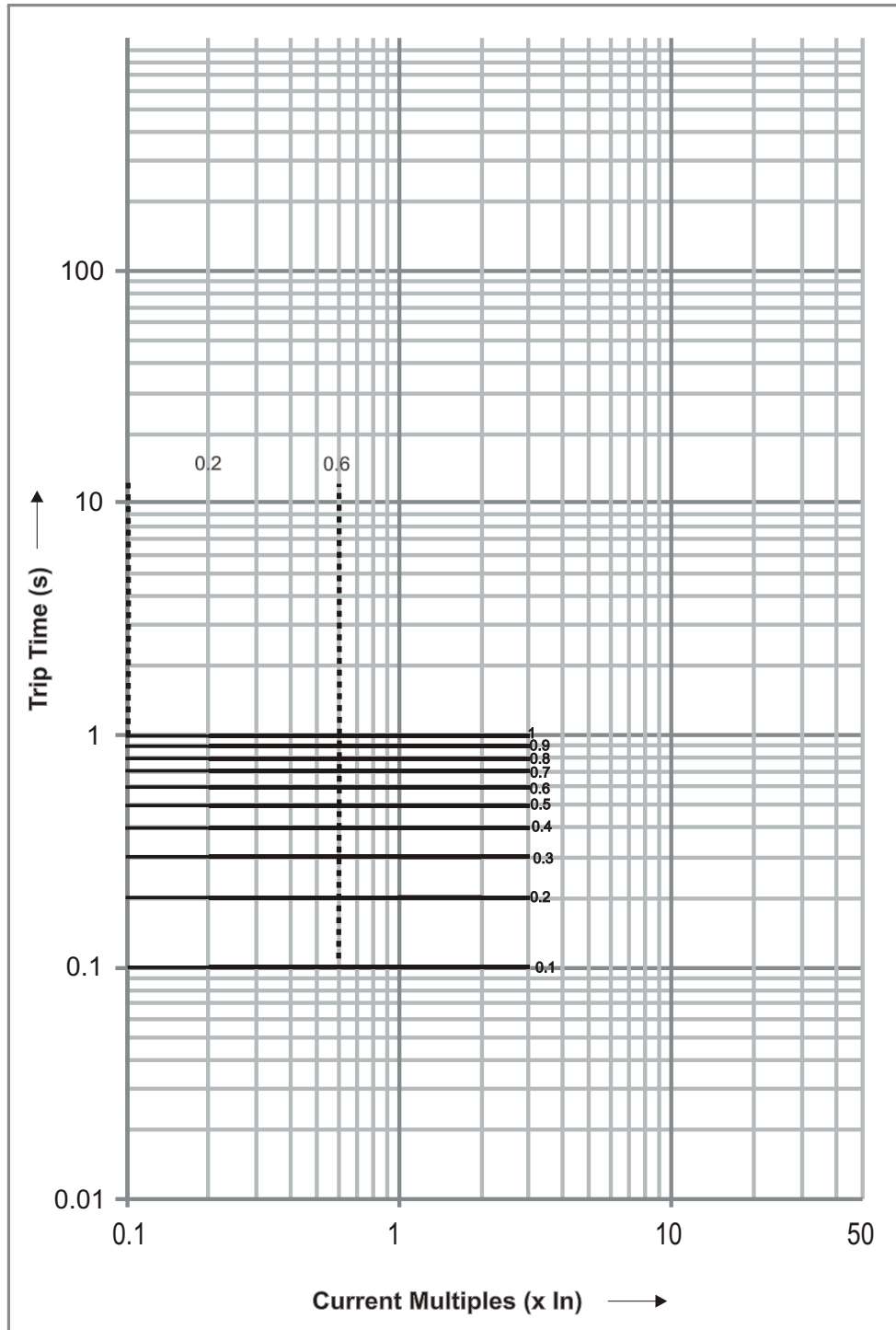

Section 6

Putting Breakers in Operation

- 6.1 Re-loading in panel
- 6.2 Checking ON-OFF operation
- 6.3 Testing
- 6.4 Setting P&C unit
- 6.5 Trip simulation of P&C unit
- 6.6 ACB in Connected Position
- 6.7 Securing

6.1 Re-loading in panel:

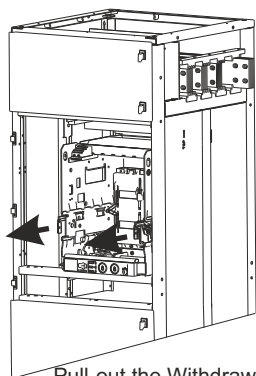

①



Pull-out the Withdrawal Rails(25) & ensure that position indication (17) shows 'DISCONNECTED'.

②

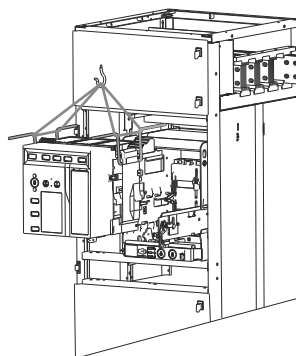

Load the breaker using crane. Even bottom trolley can be used.

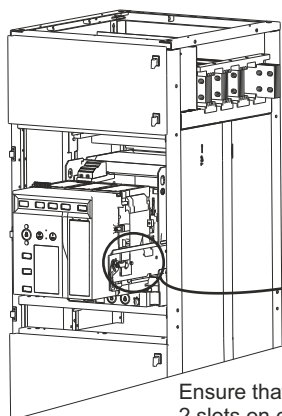

③

Ensure that Breaker rests correctly in 2 slots on either side of cradle rail (38).

CAUTION

Improper loading of breaker may lead to personal injury and damage to product.

④

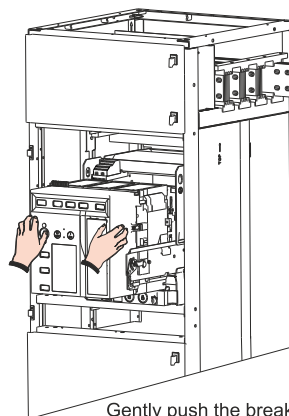

Gently push the breaker to DISCONNECTED position and close the Panel door.

If equipped with Rating Error Preventor (23), Cradle will not accept breaker of different rating & breaking capacity.

⑤

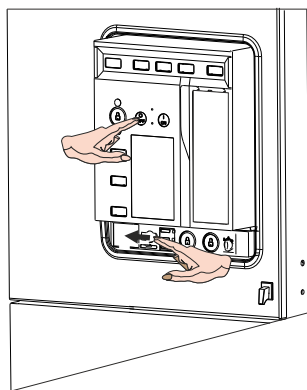

Keeping the OFF button (11a) pressed, open the Racking Shutter (16). In case panel door is open, also gently depress the Door Racking Interlock(26).

CAUTION

When panel is live, Carry-out Racking operation only with Panel Door is closed.

⑥

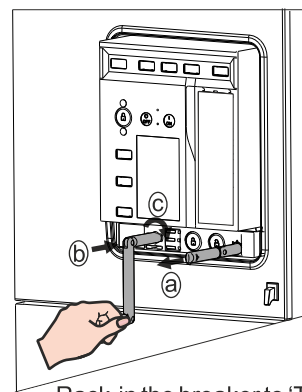

Rack-in the breaker to 'Test' position.

In Test position, if Control supply is present,
-In Electrical breakers, Electrical Charging Device(2) will start charging the spring.
-Undervoltage release(4) get energized.

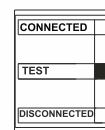

“Click”
“Click”

6.2. Checking ON-OFF Operation:

Initially, the Breaker is **OFF**  and Spring is 

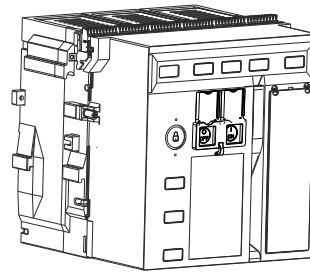

Charge the Main spring through multiple (seven) strokes of charging handle (14).

Now the breaker is **OFF**  and spring is 

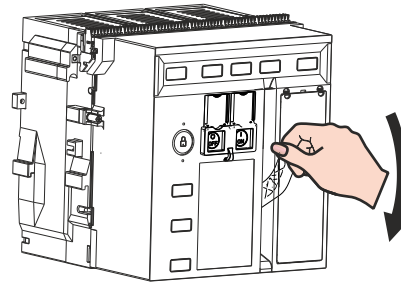

Push 'ON' button (11b) to close the breaker.

Now, the breaker is **ON**  and spring has 

In this situation, spring can be charged again for next operation.

Breakers equipped with Undervoltage release (4) cannot be normally closed unless the release is energized. Ultra Power Undervoltage release has a special feature, by which one can still check the operation. (Ref. Page 4-10 for details)

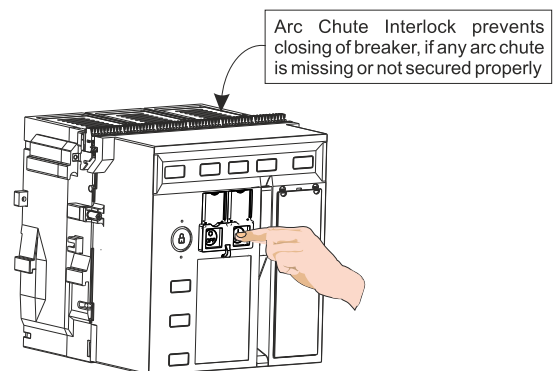

Push 'OFF' button (11a) to trip the breaker.

Now, the Breaker is **OFF**  and Spring is 

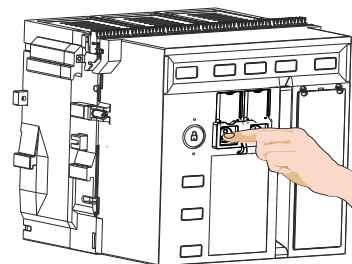

6.3 Testing (Control circuit & Interlocks):



(if breaker is equipped with accessories)

- Ensure that Breaker is in **Test position**, so that the Control circuit is connected and Main circuit is disconnected.
- Trace the Control circuit wiring based on panel wiring diagrams given by the panel builder and breaker connections given on pages 3-37 to 3-44.
- Based on the accessories fitted on the breaker, carry-out the following tests,
- If breaker is equipped with Electrical Charging Device UN-EC (2), main spring will get charged as soon as breaker reaches 'Test' position and Control supply is switched ON. If breaker is not equipped with Electrical Charging Device, charge the spring manually.
- If Undervoltage release UN-UR (4) is installed, but not energized, it will not allow the breaker to Close. However, you can continue the testing by defeating the Undervoltage release (Ref. Page 4-10)
- Ensure that all arc chutes are fitted and secured properly.
- Give supply to Closing release UN-CR (5) to close the breaker. In case not equipped with closing release, manually close the breaker by pushing the ON button (11b).
- Trip the breaker by giving supply to Shunt release UN-SR (6). In case not equipped with shunt release, manually trip the breaker by pushing the OFF button.
- After tripping through Shunt release, also check tripping through Undervoltage release, if it is energized.
- After checking the voltmetric releases, verify the functioning of other electrical interlocks and indications wherein breaker's auxiliary contacts or SICs are used.
- Also, verify the Mechanical/Key interlocking of **ULTRA-POWER** with other breakers / electrical devices in the scheme.

6.4 Configuring P&C Unit

Configuration BU-BTX 1.0/1G/1Gi/1.5G/1.5Gi

Tools required: Screw Driver (Tip width 3 mm)

P&C Units type BU-BTX1.0/1G/1Gi/1.5G/1.5Gi are pre-configured to default factory settings (ref. page 2-2). The settings can be changed to your system requirements, using the BCD switches as shown below with Breaker rating (In) of 1600A

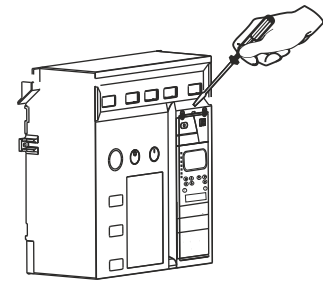

Open the release cover

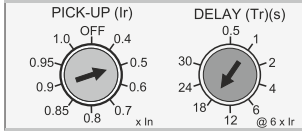
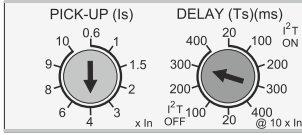
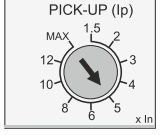
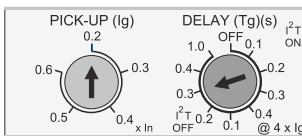
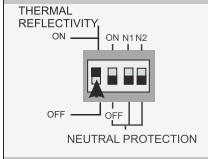
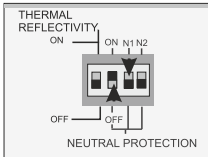
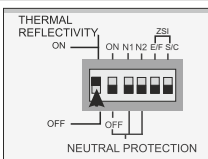
Protection	Settings	Description										
Overload		I_r is now set at 0.5×1600 i.e. 800A, with Overload delay (T) set for 18 seconds.										
Short Circuit		With knob at 4, I_s is set at 4×1600 i.e. 6400A. For this setting, select suitable time delay in 'IT OFF' mode. 'IT ON' mode offers inverse characteristics to help co-ordinate with fuses (refer page 3-6).										
Instantaneous		With knob at 5, I_p is set at 5×1600 i.e. 8000A.										
Earth Fault		With knob at 0.2, I_g is set at 0.2×1600 i.e. 320A. For this setting, select suitable time delay. 'IT ON' mode offers inverse characteristics to help co-ordinate with fuses (refer page 3-9). Note: only in BU-BTX1G & 1.5G										
Thermal Reflectivity		Activate Thermal Reflectivity, if the breaker is required to respond progressively faster for recurrent faults in Overload zone.										
Neutral Protection		To activate Neutral overload protection, set the dip switch to 'ON' position and select the Neutral rating as shown in table . <table border="1" data-bbox="901 1377 1109 1534"> <thead> <tr> <th>Neutral Protection</th> <th>N1 N2</th> </tr> </thead> <tbody> <tr> <td>50%</td> <td></td> </tr> <tr> <td>100%</td> <td></td> </tr> <tr> <td>150%</td> <td></td> </tr> <tr> <td>200%</td> <td></td> </tr> </tbody> </table> <p>■ This symbol indicates that the switch is ON. Note: only in BU-BTX1G & 1.5G</p>	Neutral Protection	N1 N2	50%		100%		150%		200%	
Neutral Protection	N1 N2											
50%												
100%												
150%												
200%												
ZSI Protection		To activate ZSI E/F and ZSI S/C , set the ZSI E/F and ZSI S/C DIP Switch to ON position.										

NOTE: BU-BTX1.0 has fixed delay of 10s for Overload protection.

6.4 Configuring BU-BTX3.5/3.5EC

1. System Settings

Setting Breaker Rating (BU-BTX-3.5/3.5EC):

Follow the mentioned steps for configuration of breaker rating

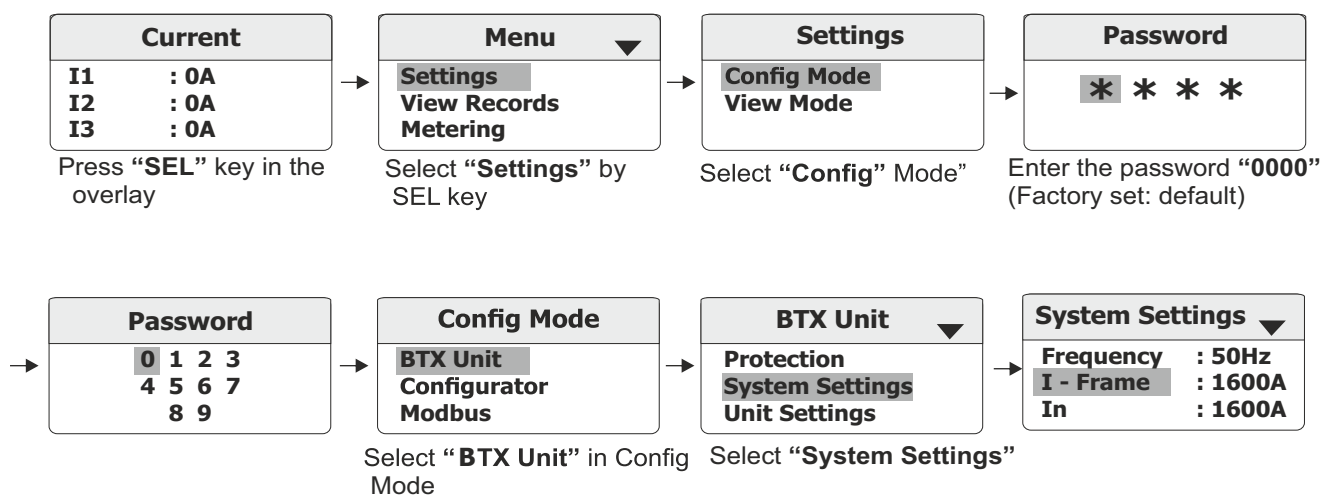

I-frame and In values shall be programmed as per following look-up table.

Breaker Frame Size	Breaker rating(A)	I-Frame in A	In in A
1,2,3	400 630 800	800	400 630 800
1,2,3	1000 1250 1600	1600	1000 1250 1600
1	2000 2500	2500	2000 2500
2,3	2000 2500 3200	3200	2000 2500 3200
3	4000 5000 6300	6300	4000 5000 6300

Save Settings ?	
Yes	No

Rest of the parameters under System settings should be set in same manner. After programming the settings, press  key to escape from menu and confirm the changes in Save Settings.

Note: To apply any parameter change in System settings in P&C unit, reset the power supply once settings are saved.

2. Unit Settings

Unit settings can be programmed following menu navigation Sequence given below

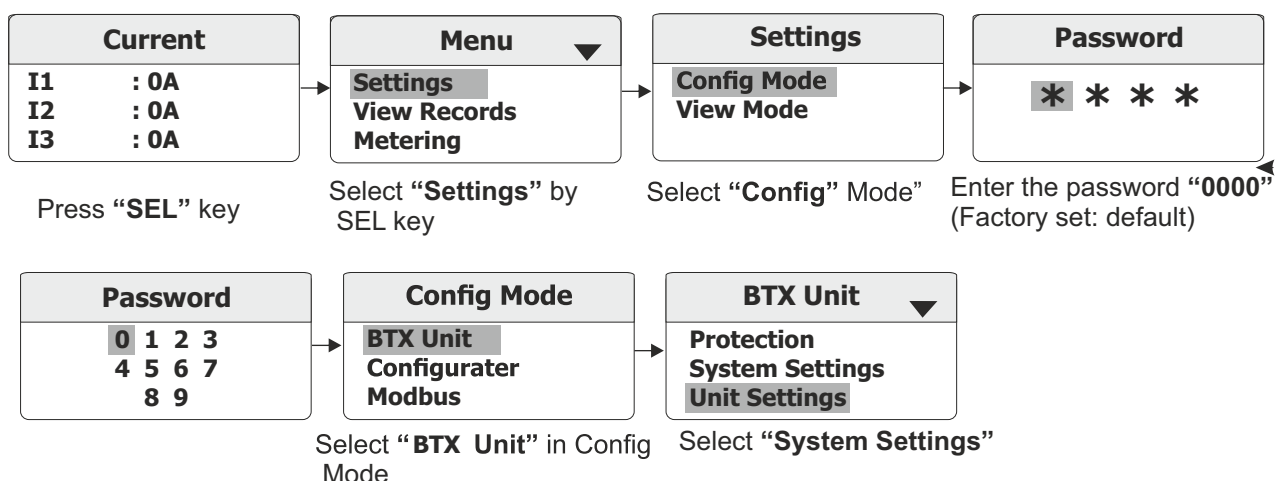

Parameters under unit settings are listed below:

Date & Time :Current date & time to be entered. Helpful for fault history time stamping.

Communication :Total 126 Device Ids are provided along with Parity option, Baud Type, Baud rate with wide range up to 19.2kbps.

Event Recorder :To capture an event viz alarm, pick-up, trip ,module connect/disconnect and maintenance.

Max Demand :Maximum demand of energy integration and refreshing interval can be selected.

Settings P/W: :The factory default settings password is "0000" which can be modified to new password by user.

Command password :The factory default command password is "0000". This password is valid for following commands enlisted in "Restore settings" menu, namely Maint.operation ,Clear MD ,Set Group ,Factory Setting, Clear Max I, Clear Max V, Clear Energies and Earth Fault test of the P&C Unit. It is configurable.

Contrast :Screen contrast can be adjusted.

Auto set GRP: :As per the factory load requirements, protections can be configured using time based set groups. Active set group will switch over to dormant set group after the set time elapsed.

Maintenance :This is password protected. Breaker Installation date shall be programmed by the service engineer.

Day Light Saving :Day light saving can be programmed through this option. Enable the Day light saving option, using "DST Mode" Enable and set the Start and End DST dates and the time which is required to add.

3. Protection

Set the protection settings as per the following menu navigation Sequence.

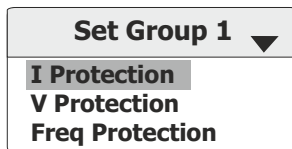
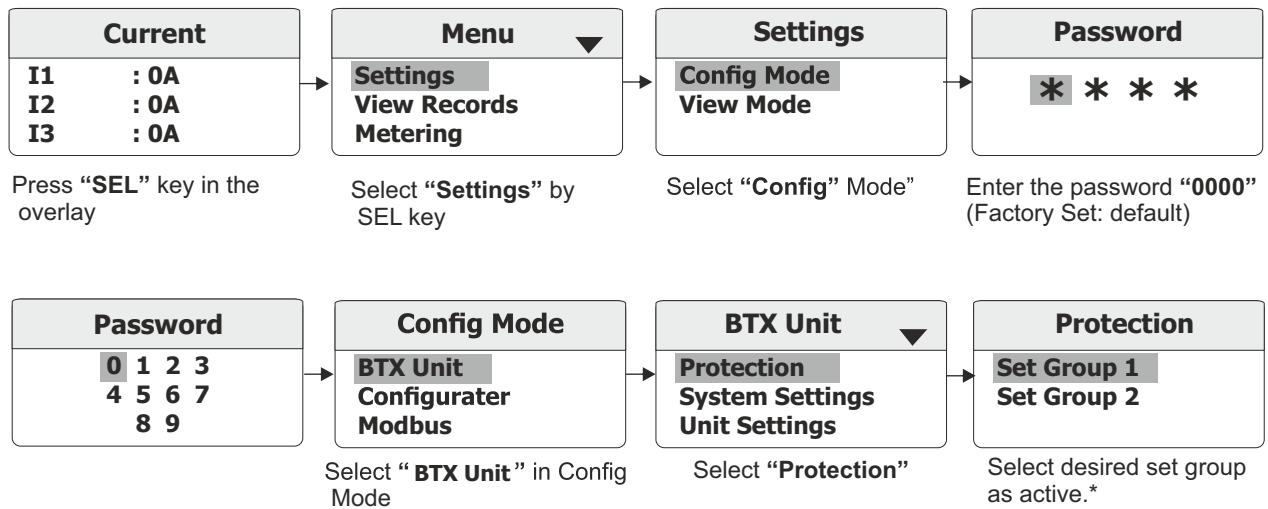

* Two interchangeable protection set groups are provided to meet different load requirements in plant. Set group 1 is Default active Set group. Time based set group can be programmed through “AUTO SET GRP”.

Protections under I- protection:

- Overload :It's a protection against over current. The characteristics provided are I_t , I_t^4 LI, SI, VI with Thermal memory. Thermal memory help to reduce the trip time of the unit in case of recursions of overload.
- Short Circuit :Excessive currents though the conductors can cause circuit damage ,fire ,explosion . This protection prevents such conditions.
- Directional SC :The protection is a short circuit protection with the ability to recognize the direction of the phases current during the fault period. The current direction makes it possible to determine whether the fault is on the supply or load side of the circuit-breaker. Particularly in ring distribution systems, this makes it possible to identify and disconnect the distribution feeder where the fault has occurred, whilst keeping the rest of the system running.
- Instantaneous :This protection works as short circuit protection with no intentional time delay which means release operates in 20milliseconds as soon as the fault current exceeds the set pick-up.

Note: Refer BU-BTX Release manual for the programming of further protections in detail.

3. Protection....continued

Earth Fault :When fault current flows from phase to earth due to rupturing of insulation, this can lead to arc flash events and electric shock. This causes more damage to the distribution system. This feature provides protection against earth fault current.

Neutral Overload :This provides protection against neutral overload at 50%, 100% & 200% of rated current. It follows overload characteristics.

Restricted EF :It works in the restricted zone of source side. It functions similar to normal earth fault protection

Earth Leakage :Earth leakage current is harmful to human body. Sensing of fault current & communicating occurrence of fault signal to the main release is being done by an earth leakage module.

Under current :Decrease in any phase current below threshold leads to under current.

Current Unbalance :It provides protection against any unbalance in phase currents .

Settings: Overload configuration:

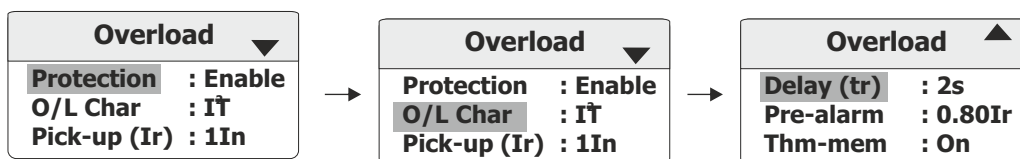

Enable O/L protection

Select O/L char. from the drop down list.

Select delay from drop down list

Similarly set all protection parameters .

Save Settings ?	
Yes	No

After programming the settings, press  key to escape from menu and confirm the changes in Save Settings. After doing all the settings Save the Set Group by pressing the escape key . "Save in Progress" message confirms the Set Group has saved.

Note: Refer BU-BTX Release manual for the programming of further protections in detail.

Protections under V- protection:

- Under voltage :When the voltage in one of the phases reduces than threshold, this protection gets activated.
- Over voltage :When the voltage in one of the phases increases above threshold, this protection gets activated.
- Voltage unbalance :Voltage unbalance creates damage to the distribution system. This protection checks voltage unbalance in all three phases.
- Residual voltage :Gives protection against the residual voltage present in the system.

Protections under Freq- protection:

- Under frequency } applicable for both control frequencies 50Hz & 60Hz.
Over frequency }

Protections under Power- protection:

- Reverse power : When the direction of the total active power reverses to that of the set direction, this protection gets activated. The direction of power depends on that of the current flowing.
- Leading PF : It checks whether the power factor is increasing beyond the set value when load is capacitive.
- Lagging PF : When the power factor for inductive load goes below the set value, this protection gets activated. It's important for any plant to maintain the power factor to unity.

Protections under other- protection:

- MD active } When max. demand of active, reactive & apparent power exceeds the set
MD reactive } value, then this protection gets activated.
MD apparent }
- Phase sequence :Mostly used for motor applications where phase reversal can be seen.
- Breaker failure : In case if the breaker fails to open under fault condition (mechanism jam, FSD malfunctions etc.) release issues one more trip command to FSD to operate the breaker as per the set delay through this protection.

Note: Refer BU-BTX Release manual for the programming of further protections in detail.

6.5 Trip Simulation of P & C Unit :



The Salient Features:

- * Generation of 3 phase current & voltage test signal (configurable Amplitude, frequency and Phase angles)
- * Simulation Kit Active Mode (Powering of Release):
2 hours & stand by mode : 2 days
- * Smart GUI with multi functional key operation
- * Graphical display (OLED)
- * Continuous battery monitoring feature
- * CT Continuity test feature
- * Memory card for data storage of test scripts and records (extendable up to 32GB)
- * Real Time Clock & Temperature sensing feature
- * Dual Power ON - Battery or external supply
- * Auto sensing of Release connectivity

Note: Refer BU-BTX Release manual for the programming of further protections and Trip Simulation Kit for testing details.

6.6 ACB in Connected Position:

1. Rack-in from 'Test' to 'Connected' position

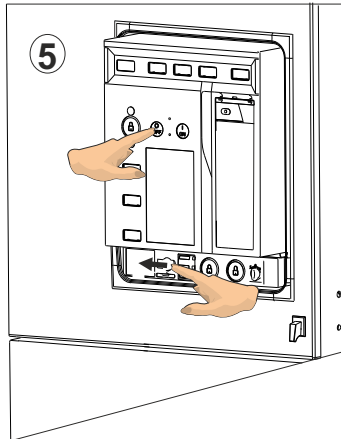

Keeping the OFF button (11a) pressed, open the Racking Shutter (16). In case panel door is open, also gently depress Racking Interlock (26).

CAUTION Carry-out Racking operation only when Panel door is closed.

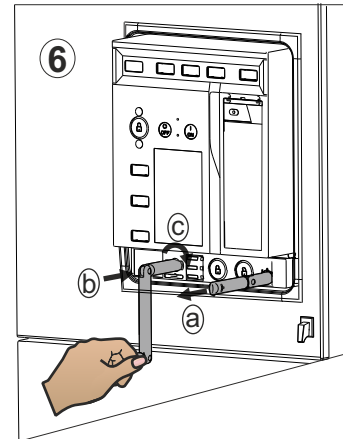

Rack-in the breaker to Connected position. Two almost-simultaneous 'Click' sounds confirm 'Connected' position.

CAUTION Excessive forceful racking-in beyond Connected position may lead to product damage.

2. Check tightness of Termination on Ultra-Power and other link/busbars.

3. Complete other Commissioning activities.

4. Check LED indication on P&C unit:

Once breaker starts carrying current, check status of 'POWER ON' LED in BTX1.0/BTX1G and OLED displaying 1.5G/3.5/3.5EC. Blinking Green LED implies that the P&C unit is healthy and is protecting your circuit.

'POWER ON' LED and OLED display is OFF when there is no/minimal current in the main circuit.

Metering display:

Once breaker starts carrying current, BU-BTX units display current values in default metering screen.

BU-BTX units display current, Voltage, Frequency, PF, Power, Energy, Max Demand, Temperatures values in auto scrolling mode*.

Default current metering screen is shown as an example. 1,2,3 represent R, Y, B phases respectively.

*depending on the configuration selected.



6.7 Securing your Breaker:

ACB offers several security features to prevent unauthorized access and inadvertent operation.

ON-OFF Button padlocking (11):

To prevent unauthorized access, ON / OFF buttons can be padlocked or sealed, together or individually.

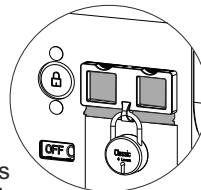

Padlocking both buttons

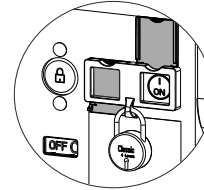

Locking any one button

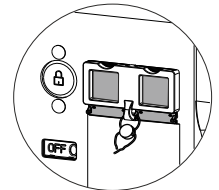

Sealing Either/Both buttons

Sealing the Release cover (31):

Protection setting for Release can be secured using a standard lead seal.

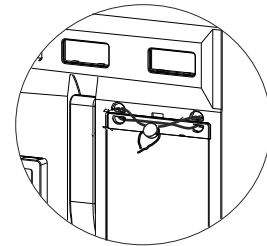

Smart Racking shutter padlocking (16a):

Tools required: Screw Driver (Tip width 3 mm)

To prevent inadvertent racking operation, smart racking shutter can be padlocked, when breaker is in distinct Service, Test or Isolated positions and racking shutter is closed. Upto 3 padlocks can be used at a time.

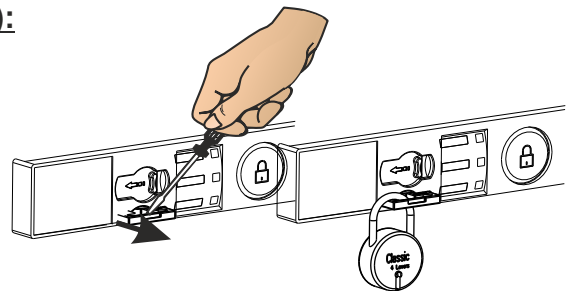

Safety shutter padlocking:

USERS can padlock top or bottom part of the Safety shutter to secure access to Line and/or load side.

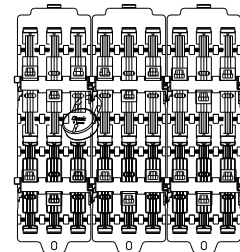

Locking OFF button (18):

Breaker can be locked in 'OFF' condition to prevent unauthorized 'ON' operation. This feature is mainly used for interlocking with other breakers or electrical devices in an electrical scheme.

Press the 'OFF' button (11a) and turn the key. When key is removed, the breaker remains locked in OFF position. For switching the breaker 'ON', reinsert the key & turn to release OFF button.

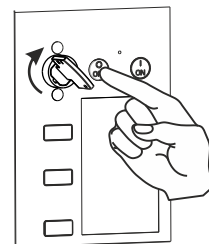

Section 7

Maintenance & Operations

7.1 Maintenance schedule & Operations

7.2 Accessories and Spares

7.1 Maintenance Schedule & Operations:

Regular maintenance of **Ultra - Power** Series of breaker will help ensure proper operation, reliable protection and enhanced product life.

CAUTION

- This device should be maintained by authorised qualified personnel only.
- Ensure that main and control supply is disconnected, before commencing any work on the device.
- Failure to meet the above precautions can lead to electrocution and result in serious injury / death to personnel.
- It is recommended to call Authorised Service Centre for servicing the breaker.
- After maintenance, in P&C unit (BU-BTX3.5/3.5EC) give "Yes" command to the "Maintenance" in "Restore Settings" .

Nature of Maintenance	Schedule/Frequency	Actions	Reference
Routine	Monthly	Check LED indication on P&C unit	7.1a
	Quarterly	Self-diagnostic test of P&C unit	7.1b
		Temperature check at termination	7.1c
	Yearly	Open & Re-close the breaker	7.1d
		Rack-out & Rack-in the breaker	7.1e
		Inspect Arc Chutes for erosion	7.1f
		Inspect Contacts for erosion	7.1g
		Trip simulation of P&C unit	6.5
1 Year or 500 operations (whichever is earlier)	Greasing of Operating Mechanism	7.1h	
Specific	When P&C unit trips the breaker	Identify the fault & Reset P&C unit	7.1i
	When any Electrical accessory needs replacement	Replace the specific accessory	7.1j
	When breaker clears a major fault	Inspect Arc Chutes for erosion & replace, if required	7.1g
		Inspect contacts for erosion & replace Main Contacts, if required	7.1g & 7.1k
	In case of an abnormal external event, such as flashover in panel	Inspect Jaw Contacts & replace, if required	7.1l
		Inspect Cradle Terminals and replace, if required	7.1m
	On completion of Electrical life	Replace all Arc Chutes	7.1f
Replace all Main Contacts		7.1k	

7.1a Checking LED indication on P&C unit:

Tools required: None

If 'POWER ON' LED is Blinking Green, it implies that the P&C unit is healthy and is protecting your circuit.

If ' POWER ON' LED is OFF when there is no/minimal current in the main circuit.

POWER ON LED →

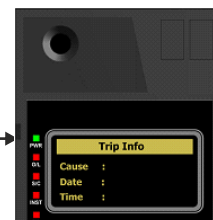

7.1b Earth fault test of P&C unit(BU-BTX2.5/2.5G/3.5/3.5EC):

Tools required: Screw Driver (Tip width 6 mm max)

Remove cover of P&C unit and press 'T' button. Enter the Command password (Default factory set password is "0000").Unit issues trip in EF and trip, E/F LED glows.

To reset the LEDs, again press the "T" button once the breaker is closed and re-enter the password. This procedure verifies unit is healthy to issue trip in Earth Fault.

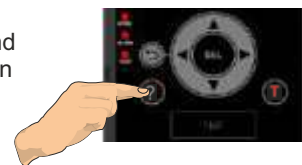

7.1c Temperature Check:

Tools required: Infrared Temperature Scanner

Overheating at terminals and joints can result in serious accidents including flashovers. Regular temperature checks at termination using an 'Infrared Temperature Scanner' will help detect any overheating for timely preventive action.

7.1d Breaker operation:

Tools required: None

In several cases, breaker is rarely operated. Hence, it is important to open and re-close the breaker at regular intervals (ref. Section 2.4). Also check for healthy operation of accessories such as Electrical charging device, Closing release and Shunt release.

7.1e Racking operation:

Tools required: None

If breaker is not being racked-out in a year, it is recommended to carry-out racking operation of the breaker as a part of routine maintenance. Procedure for Racking out & in is detailed in sections 2.2 & 3.3 respectively.

Door Interlock defeat (40):

Tools required: Philips Head Screw driver (Tip number 2)
Screw driver (Tip width 6 mm)

If the breaker is equipped with Door interlock, panel door cannot be opened when breaker is in Service condition.

If it is necessary to open the panel door with breaker in Service condition, Door Interlock can be defeated as illustrated herewith.

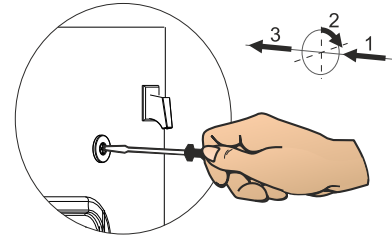

CAUTION

Opening panel door when breaker terminals are live, may lead to electric shock and personal injury.

Door Racking Interlock defeat (26):

Tools required: None

Door Racking interlock prevents opening of smart racking shutter (16) and thus, racking in/out of the breaker when panel door is open.

If it is necessary to rack-out the breaker with panel door open, racking interlock must be defeated. For opening racking shutter pen, gently depress the racking interlock lever (26) in addition to keeping 'OFF' button (11a) depressed.

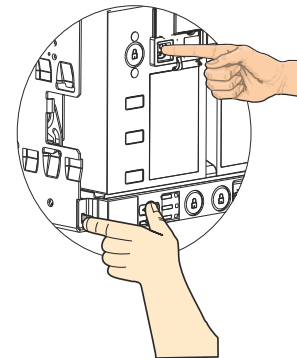

CAUTION

It is recommended to carry-out racking operation only with panel door closed.

7.1f Inspecting Arc-chutes (21) for erosion:

Up to 690V AC

Tools required: None

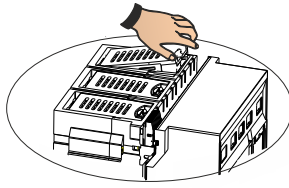

Pull back the knob and lift the front side of the arc chute.

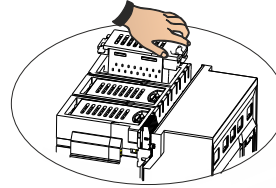

Disengage the rear side and lift arc chute.

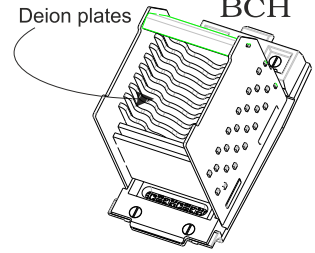

Check deion plates for erosion. If plates develop sharp knife-edges, replace arc chute.

800/1000V AC

Tool required: Box type spanner for M6

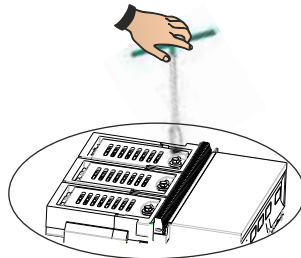

Remove arc chute fixing screw using box spanner.

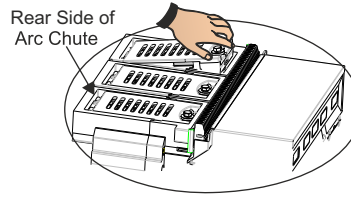

Lift the arc chute then disengage from rear side and remove.

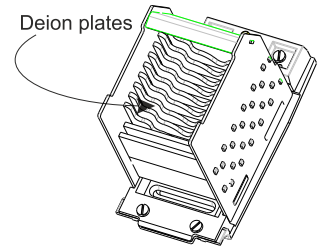

Check deion plates for erosion. If plates develop sharp knife-edges, replace arc chute.

7.1g Inspection of Contacts for erosion:

Once Arc chutes are opened, contacts are visible and can be inspected for erosion.

Tool required : None

Ultra-Power ACB poles are equipped with an indicator for contact condition.

The adjoining detailed sketch shows the rear edge of the moving contact with breaker in 'Closed' condition. As contact get eroded, the rear edge moves in the direction indicated by an arrow in the shaded area.

Condition of contact is indicated by alignment of the rear edge with one of 3 markings on the indicator.

This feature is only for indication purposes and contacts should be replaced after cleaning major fault/on completion of electrical life indicated.

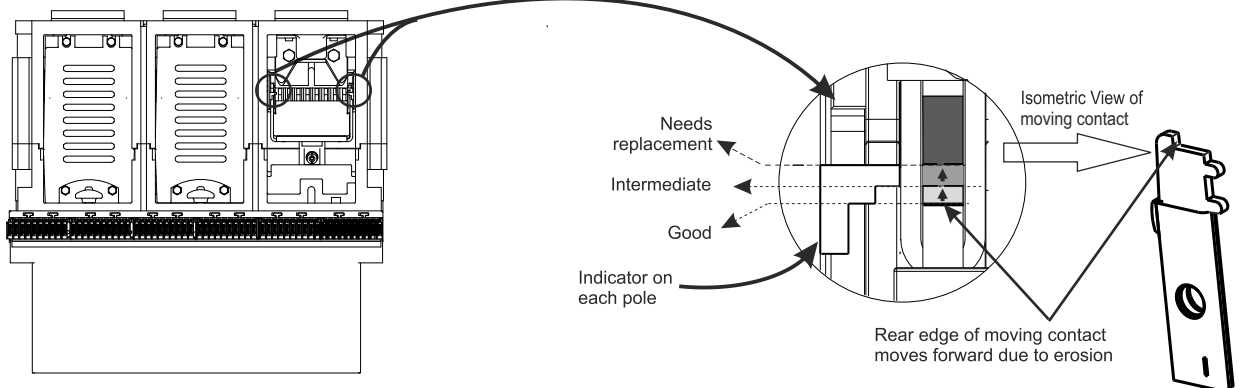
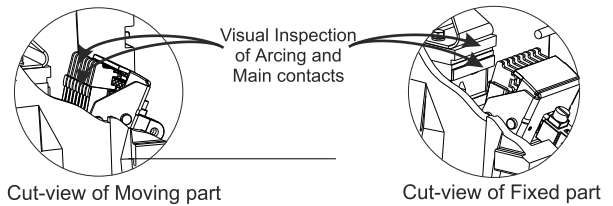

7.1h Greasing of Mechanism:

Greasing schedule Mechanism : 1 Year or 500 operations, whichever is earlier. Grease to be used in Mechanism - Parts 1 to 6: Red Grease (MobilithSHC-100 of Mobil); Parts 10 & 11 (plastic parts) on right hand side of Mechanism: White Grease (MOLYKOTE 33 MEDIUM)
 Greasing schedule Cradle : 1 Year or 50 operations, whichever is earlier Grease to be used on parts 1 to 9 of Cradle: Red Grease (MobilithSHC-100 of Mobil)

The following components can be greased, without dismantling any accessory or component, using a brush.

- 1 : Pole shaft bearing (all)
- 2 : Bearings (both sides of mechanism)
- 3 : Cam Profile
- 4 : Top surface of links (2)
- 5 : Top surface of link
- 6 : Rubbing surface of link

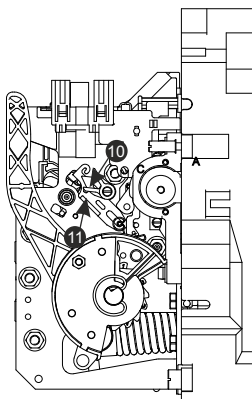

Apply grease to the specified components at rubbing surfaces

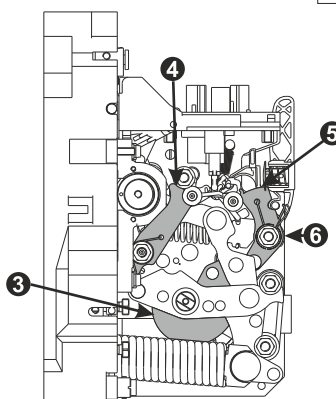
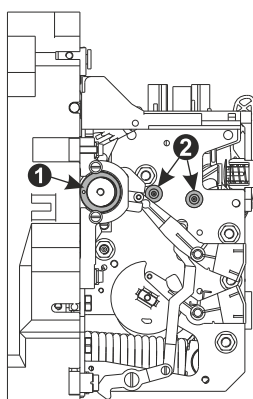

Simplified diagram for identification of components to be greased.

CAUTION

Non-adherence to greasing schedule or using other-than-specified grease may lead to malfunction.

Ensure that ACB is OFF and Spring is Discharged, before commencing greasing operation.

- 1 : Racking Screw
- 2 : Racking Cam & Drop Pin joint
- 3 : Base Plate
- 4 : Rail Sliding surface on Side plate
- 5 : Racking Cam & Service Latch follower
- 6 : Gear Teeth & Rack Slots
- 7 : Bottom & side Sliding Surfaces of Rails on Side Plate
- 8 : Service Latch on Side Plates
- 9 : Guiding surface of cradle SIC Bridge

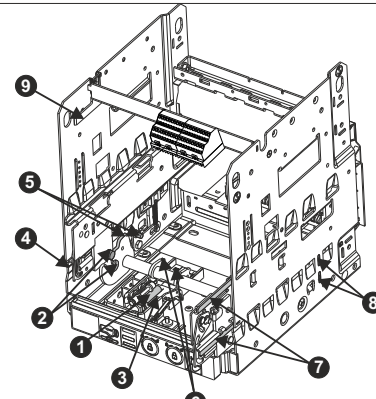

Simplified diagram for identification of components to be greased.

The following components are not to be greased:

- A : All releases & all connectors
- B : Main contacts in pole & top terminal, breaker adaptors, jaw clusters, breaker & cradle terminals
- C : Earthing terminal
- D : Secondary isolating contacts
- E : Dynamic latch
- F : All type of locks

7.1i Fault identification and resetting:

Tools required: Screw Driver (Tip width 6 mm max)

Fault identification:

- 1) When P&C unit trips the breaker, a mechanical indication is provided through popping-out of the red pointer at the upper end of the unit.

With Auto reset feature, the pointer will reset automatically.

- 2) To identify the type of fault, open the P&C unit cover and press 'Query' button. The LED corresponding to the fault seen by the breaker will glow. This local fault indication is independent of auxiliary supply or batteries and is available to USERS for repeat usage* after the fault.

- 3) Select versions of BU-BTX (Ref. page 5-2) provide separate remote indication of fault type, when auxiliary supply is available..

Reclosing the breaker:

- 4) After taking the necessary corrective action. Press 'Clear' button to reset the fault indication.
- 5) For breakers with 'Manual resetting mode', push-in the red pointer and fix the release cover back.

Now, breaker can be reclosed as per procedure given on page 6-2.

* Availability of indication depends on time elapsed after the Fault and duration for which 'Query' button is pressed.

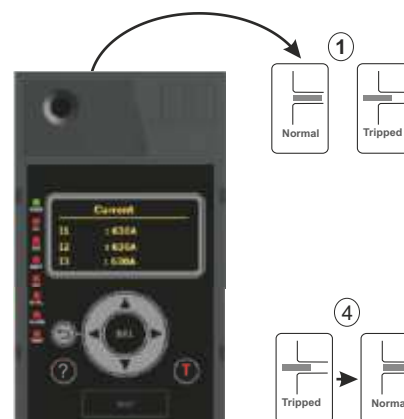

Fault diagnosis in BU-BTX1.0/1.0+ Units

On pressing Query("?) button, the OLED screen indicates "Trip Info" which includes cause, Date and time of the fault.

P&C unit stores 5 Trip Records and 10 Event records which can be read when auxiliary supply(24 dc) is present. Trip Record contains current, voltage frequency levels of the system when the fault occurred. Event Record records the events like pick-up,alarm and trip.

7.1j Replacement of Electrical Accessories:

Tools required: Screw Driver (Tip width 3 mm)
Allen key 5 mm (for Electrical Charging Device)

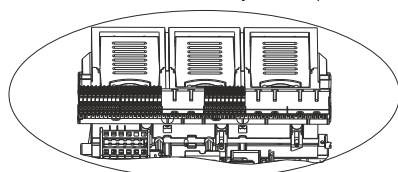

After removing facia
access breaker SIC

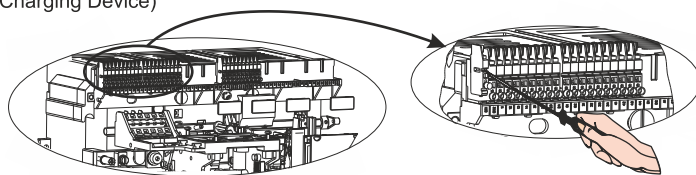

Pull out the specific breaker SIC
from the bridge with the screw driver

For removing Voltmetric release, depress the lever under the release and slide it out.

For removing Electrical Charging Device, remove 2 allen screws.

Install the new accessory and fix new breaker SICs, pre-wired with the new accessory.

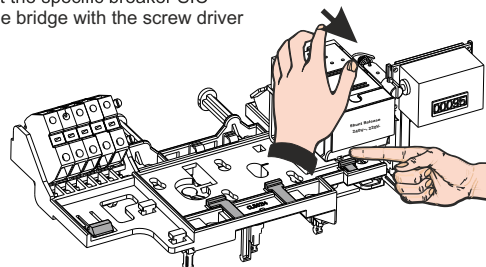

7.1k Replacement of Main Contacts:

facilitates replacement of pole assembly in a phase-by-phase manner. USERS can determine whether to replace one pole or multiple poles, based on condition of contacts. However, at the end of electrical life, all poles need to be replaced.

Tools required:

- Screw Drivers : a. Tip width 8 mm or Philip head (Tip no. 2)
b. Length 200mm min, Tip width 6 mm, Tip thickness 1 mm max
- Allen Key : 5 mm, Shank length 120 mm
- Box spanner : M6, length 300 mm min.

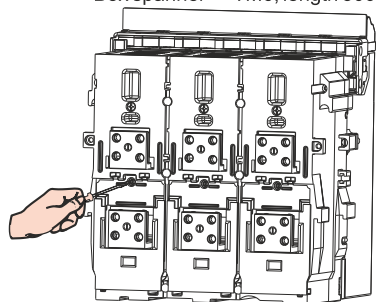

First close the breaker and then
remove Arc chutes & CT covers

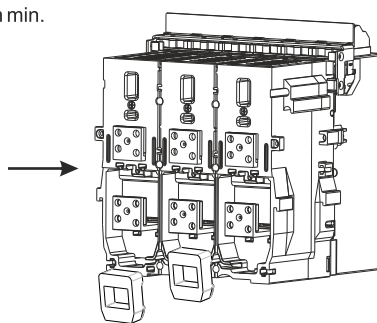

Remove the CTs, without disturbing
their connections with the P&C unit.

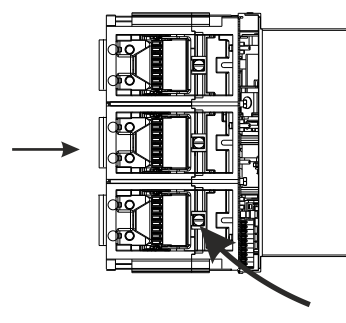

Remove connector pin and trip
the breaker.

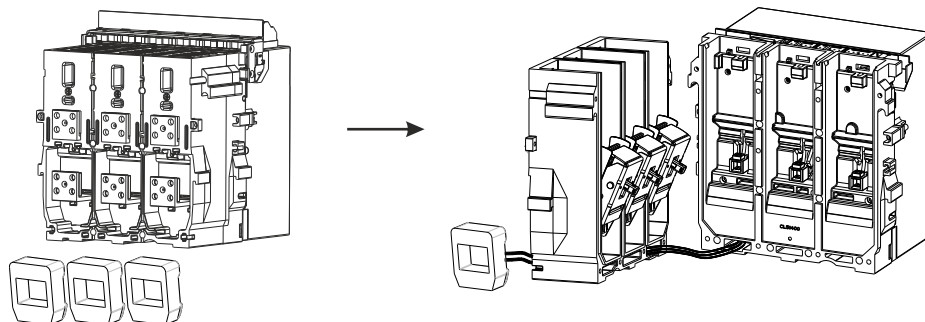

Remove hex socket head screws (10 nos.), using min. 80 mm long M6 key.

Separate rear housing from front housing, without disturbing CT wires.

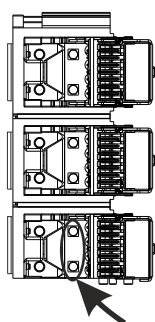

Remove fasteners.

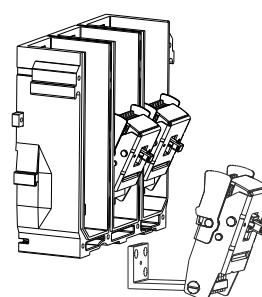

Moving part of the pole can now be removed

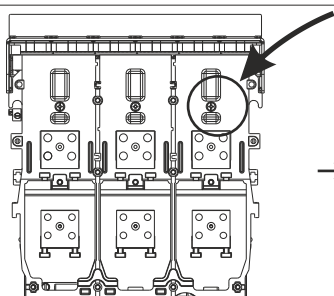

To take out fixed part of the pole, remove 1 screw from rear side and 2 screws from top as shown.

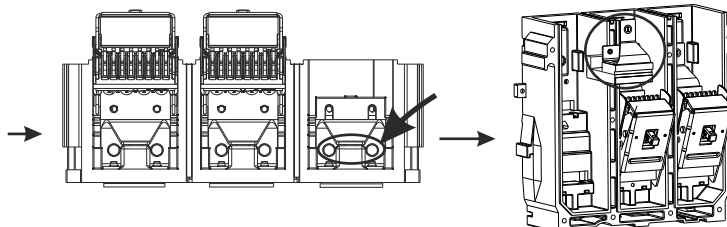

Replace fixed part of the pole.

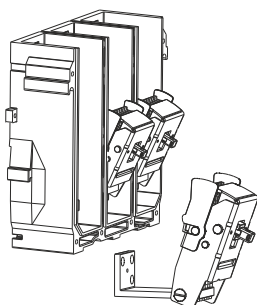

Also, replace Moving part of the pole.

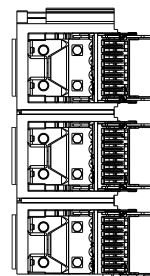

Refix fasteners. Align front & rear housings and tighten hex socket head screws.

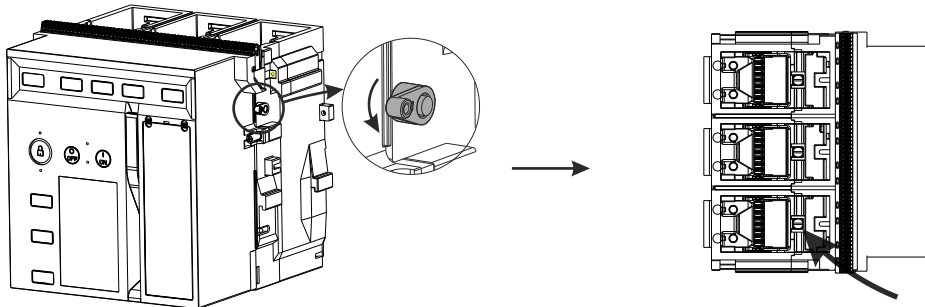

Depress Arc-chute Interlock lever to defeat the interlock and close the breaker.

Refix the connector pin, followed by CTs and CT covers. After verifying closing of poles through few ON-OFF operations, refix the arc chutes.

7.1I Replacement of Jaw contacts (3j):

Contact Jaws may require replacement in the event of a flashover or on clearing a major fault.

Tools required: None*

Jaws can be replaced without using any tool. Slightly rotate the jaw left or right to remove it.

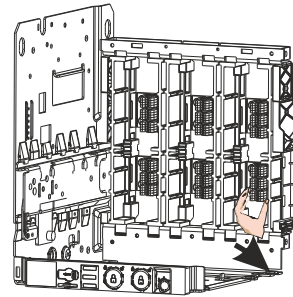

7.1m Replacement of Cradle Terminals & Supports (35):

Tools required: Screw Driver (Blade - Length 300 mm & Dia 8 mm, Tip width 8 mm)

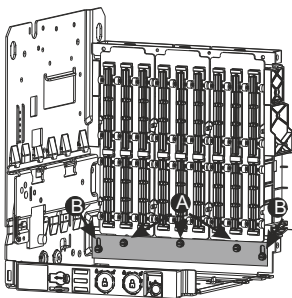

Remove screws 'A' and loosen screws 'B'. As a result, Removing of Safety Shutter, jaws and Terminal support clamp will drop down.

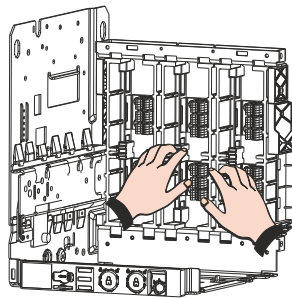



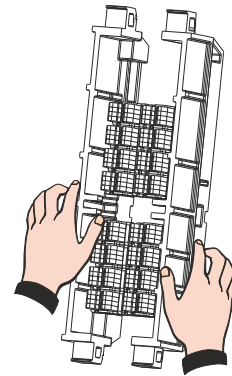



Pull out the cradle terminal assembly using projections on the terminal support.

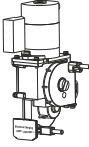
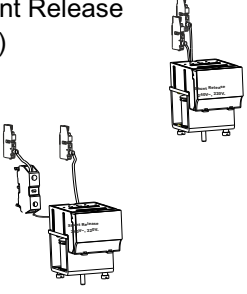
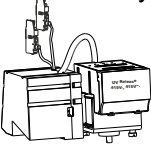

Now you can replace the cradle terminals & Jaw Cluster assemblies.

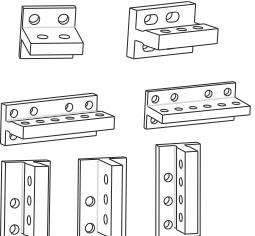
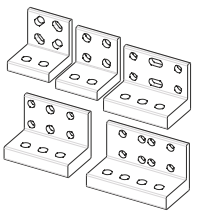
7.2 Accessories & Spares











Sr. No.	Component	Cat No.		Units per Cat No.	Units per ACB*			
1	Electrical Charging Device (ECD) 	AC 50/60Hz	110 V	BLECD903600000	1	1		
			220 V	BLECD903640000				
			240 V	BLECD903590000				
			415 V	BLECD903610000				
		DC	24/30 V	BLECD903620000				
			48/60 V	BLECD903630000				
			110/125 V	BLECD903600000				
			200 V	BLECD903640000				
			250 V	BLECD903590000				
			400 V	BLECD903610000				
2	Shunt Release (SR) 	AC 50/60 Hz	110 V	BLSH908160A00	1	1		
			220 V	BLSH908160B00				
			240 V	BLSH908160B00				
			415 V	BLSH908160D00				
		DC	24 V	BLSH908160400				
			30 V	BLSH908160400				
			48 V	BLSH908160500				
			60 V	BLSH908160500				
			110 V	BLSH908160A00				
			125/127 V	BLSH908160100				
			220 V	BLSH908160B00				
			250 V	BLSH908160B00				
			SRW (Wide band 10-130%)	AC 50 Hz			240 V	BL908230B00
							415 V	BL908230D00
3	Undervoltage Release (With/Without Delay -UVR) 	AC 50/60Hz	110 V	BLUV90818A000	1	1		
			240 V	BLUV90818B000				
			415 V	BLUV90818D000				
		DC	24/30 V	BLUV908184000				
			48 V	BLUV908185000				
			110 V	BLUV90818A000				
			220 V	BLUV90818B000				
			250 V	BLUV90818B000				
4	Closing Release (CR) 	AC 50/60Hz	110 V	BLCR90817A000	1	1		
			220 V	BLCR90817B000				
			240 V	BLCR90817B000				
			415 V	BLCR90817D000				
		DC	24 V	BLCR908174000				
			30 V	BLCR908174000				
			48 V	BLCR908175000				
			60 V	BLCR908175000				
			110 V	BLCR90817A000				
			125/127 V	BLCR908171000				
			220 V	BLCR90817B000				
			250 V	BLCR90817B000				

Sr. No.	Component	Cat No.	Units per Cat No.	Units per ACB [#]		
5	Protection&Control Units 	BU-BTX1.0	BLBTX919660000	1	1	
		BU-BTX1.0G	BLBTX919710000			
		BU-BTX1.0Gi	BLBTX905620000			
		BU-BTX1.5G	BLBTX919650000			
		BU-BTX1.5Gi	BLBTX905520000			
		BU-BTX 2.5	BLBTX901120000			
		BU-BTX 2.5G	BLBTX906100000			
		BU-BTX 3.5	BLBTX901130000			
		BU-BTX 3.5EC	BLSK907000000			
		BU-BTX 3.5H	BLBTX919750000			
	BU-BTX 4.5	BLBTX906110000				
	Power Supply Module	UN-PS	BLSK907220000	1	1	
6	External Simulation kit	Matrix	BLSK907240000	1	1	
7	Terminal Adaptor for one side (Incoming or Outgoing) Drawout ACBs 	Frame-1		1	3 for 3 Pole 4 for 4 Pole	
		400-2000A	Horiz./Vert.			BLCA609630000
		2500A	Vertical		BLCA609640000	
		Frame-2			3 for 3 Pole 4 for 4 Pole	
		400-3200A	Horiz./Vert.			BLCA609640000
		4000A	Vertical		BLCA604200000	
			Horizontal		BLCA603160000	
		Frame-3			Vertical 6 for 3 Pole 8 for 4 Pole	
		400-4000A	Vertical			BLCA601280000
			Horizontal ^{###}			BLCA600730000
		5000A	Vertical	BLCA600670000		
			Horizontal ^{###}	BLCA609660000		
		6300A	Vertical	BLCA609650000		
	Fixed ACBs 	Frame-1		1	3 for 3 Pole 4 for 4 Pole	
		400-2000A N/S	Horiz./Vert.			BLCA609670000
		400-2000A H	Horiz./Vert.		BLCA609680000	
		2500A S/H	Vertical		BLCA609760000	
		Frame-2			3 for 3 Pole 4 for 4 Pole	
		400-2500A N/S	Horiz./Vert.			BLCA601220000
		400-3200A N/S/H	Horiz./Vert.			BLCA609770000
4000A S/H		Vertical	BLCA604170000			
Frame-3		6 for 3 Pole 8 for 4 Pole				
400-5000A			Horiz.		BLCA903730000	
400-4000A	Vertical		BLCA604180000			
	5000A	Vertical	BLCA603470000			
8	Auxiliary contacts (4NO+4NC)		BLSK907450000	1	1	
9	Rating Error Preventor		BLBC906670000	1	1	
10	Racking handle 	Fr-1-3P, Fr-1-4P, Fr-2-3P	BL900100000	1	1	
		Fr-2-4P, Fr-3-3P, Fr-3-4P	BL902900000			

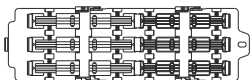

Quantities for all 4-pole ACBs pertain to 100% N rating

Horizontal for bus-coupler application of ACBs only

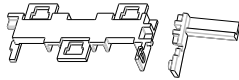

* Available upto 3200A

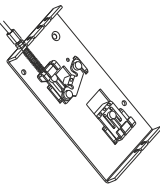
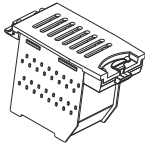
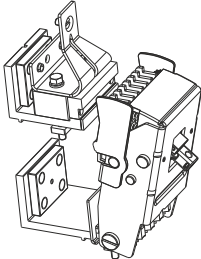
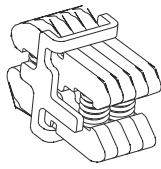
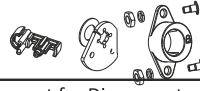
Sr. No.	Component		Cat No.	Units per Cat No.	Units per ACB*		
11	Safety Cover	 For Drawout ACB	BL908400000	1	1		
12	Door Racking Interlock		BL909790000	1	1		
13	Door Interlock		BL909780000	1	1		
14	Shroud for ON/OFF Buttons		BL909740000	1	1		
15	Operation Counter		BL909830000	1	1		
16	Set of Lifting hooks		BL604060000	1	1		
17	Secondary Isolating Contacts (Connected & Test position) for Breaker & Cradle		BLEPI958250000	1 block (10 each)	As required		
18	Electrical position indication		BLEPI958260000	1	1		
19	Panel Door Ingress Seal		Fixed ACB BLBC906950000 Draw-out ACB BLBC906960000	1	1		
20	Safety Shutter Without Padlock		3-pole	Frame 1 / 2	BL900160000	1	3
				Frame 3			6
			4-pole	Frame 1 / 2	BL900160000	1	4
				Frame 3			8
21	Safety Shutter Padlock		3/4 pole	Frame 1 Frame 3	BL909970000	1	6 or 8 12 or 16
22	Safety Shutter Padlock		3/4 pole	Frame 2	BL900560000	1	6 or 8

* Quantities for all 4-pole ACBs pertain to 100% N rating

Sr. No.	Component	CAT No.	Units per CAT No.	Units per ACB*	
23	Mechanical Interlock (2 metre, 3 metre and 5 metre) 	2 Incomers (2m)	1 set	1 set per scheme	
		3 Incomers (2m)			
		2 Incomers & 1 Standby (2m)			
			2 Incomers & 1 Buscoupler (2m)	1 set	1 set per scheme
			2 Incomers (3m)		
			3 Incomers (3m)		
			2 Incomers & 1 Standby (3m)	1 set	1 set per scheme
			2 Incomers & 1 Buscoupler (3m)		
			2 Incomers (5m)		
			3 Incomers (5m)	1 set	1 set per scheme
	2 Incomers & 1 Standby (5m)				
	2 Incomers & 1 Buscoupler (5m)				
24	Arc Chute 	Frame 1 N/S/H	1	3 for 3 pole	
		Frame 2 N/S/H		4 for 4 pole	
		Frame 3 N/S/H/V		6 for 3 pole 8 for 4 pole	
25	Main Contacts Assembly 	Fr. 1 : 400-1600A N Version	1	3 for 3 pole 4 for 4 pole	
		Fr. 1 : 2000A N Version			
		Fr. 1 : 400-1600A S Version			
		Fr. 1 : 2000A S Version			
		Fr. 1 : 2500A S Version			
		Fr. 1 : 400-2500A H Version			
		Fr. 2 : 400-2500A N/S Version			
		Fr. 2 : 3200A N Version			
		Fr. 2 : 3200A S Version			
		Fr. 2 : 400-3200A H Version			
		Fr. 2 : 4000A S/H Version			
	Fr. 3 : 400-6300A H Version	6 for 3 pole 8 for 4 pole			
	Fr. 3 : 400-6300A V Version				
26	Jaw Contacts 	Fr. 1 : 400-1600A N Version	12	Per Pole - 4	
		Fr. 1 : 2000A N Version		Per Pole - 6	
		Fr. 1 : 400-1600A S Version		Per Pole - 6	
		Fr. 1 : 2000A S Version		Per Pole - 8	
		Fr. 1 : 2500A S Version		Per Pole - 12	
		Fr. 1 : 400-2500A H Version		Per Pole - 12	
		Fr. 2 : 400-2500A N/S Version		Per Pole - 12	
		Fr. 2 : 3200A N/S Version		Per Pole - 16	
		Fr. 2 : 400-3200A /H Version		Per Pole - 16	
		Fr. 2 : 4000A S/H Version		Per Pole - 20	
		Fr. 3 : 400-4000A /H/V Version		Per Pole - 12	
		Fr. 3 : 5000A H/V Version		Per Pole - 12	
		Fr. 3 : 6300A H/V Version		Per Pole - 20	
27	Locking Arrangement for OFF Button 	for Castell Lock	1	1	
		for Ronis Lock			
		for Kirk Lock			
		for Profalux Lock			
28	Locking Arrangement for Disconnected Position 	for Castell Lock	1	1 or 2 as required	
		for Ronis Lock			
		for Kirk Lock			
		for Profalux Lock			

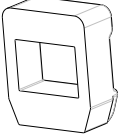
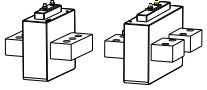
* Quantities for all 4-pole ACBs pertain to 100% N rating

Sr. No.	Component	CAT No.	Units per CAT No.	Units per ACB*					
29	Locking Arrangement for all Position 	for Castell Lock	BLCLC909810000	1	1 or 2 as required				
		for Ronis Lock	BLCLR909270000						
		for Kirk Lock	BL908680000						
		for Profalux Lock	BL908690000						
30	C.T. Wire Harness for Matrix	Frame 1-3P	BL006870000	1	1				
		Frame 1-4P	BL006880000						
		Frame 2-3P	BL006890000						
		Frame 2-4P	BL006900000						
		Frame 3-3P	BL006910000						
		Frame 3-4P	BL006920000						
		Frame 3-4P, 50% N	BL006930000						
31	Current Transformer (Internal) 	Frame 1	400/630/800A	BLEN007000000	1	3 for 3 pole 4 for 4 pole			
			1000/1250/1600A	BLEN007010000					
			2000/2500A	BLEN007020000					
		Frame 2	400/630/800A	BLEN007250000			6 for 3 pole 8 for 4 pole		
			1000/1250/1600A	BLEN007030000					
			2000A/2500A/ 3200/4000A	BLEN007040000					
		Frame 3	400/630/800A	BLNC007260000					
			1000/1250/1600A	BLNC007270000					
			2000A/2500A/ 3200A/4000A	BLNCL007050000					
		5000A/6300A	BLNC007060000						
		32	Current Transformer for External Neutral 	Frame 1,2,3		400/630/800A	BLEN007170000	1	1
						1000/1250/1600A	BLEN007180000		
Frame 1	2000/2500A			BLEN007190000					
Frame 2,3	2000A/2500A/ 3200A/4000A			BLNC007200000					
Frame 3	5000A/6300A			BLNC007210000					
33	Trip Indication for 	Undervoltage release	BLUM909470000	1	1				
		Shunt release	BLSM909510000	1	1				
		Common fault indication	BLCM909490000	1	1				
		Ready-to-Close indication	BLRCM909530000	1	1				

* Quantities for all 4-pole ACBs pertain to 100% N rating

Section 8

Useful Hints



Useful Hints



Situation	Probability	Solution
ACB does not close on pressing "ON" button	One or more arc-chute(s) not secured properly	Press each arc chute firmly by hand
	U/V release is present but not energized	Energize U/V release
	Mechanism spring is not charged. Indicator is in black background	Charge the mechanism spring manually till a distinct sound is heard & indicator turns yellow
	Trip Reset link is projecting out	Press trip reset link to reset position
	Smart Racking Shutter is open	Close the Smart Racking Shutter (Insert Racking Handle once & pull back)
	"OFF" button is locked	Unlock "OFF" button
Mechanical Interlock disables closing		Re-check before attempting to close the breaker
Smart Racking Shutter does not re-close automatically after racking handle is pulled out	Breaker is in-between Connected/Test/Disconnected position. Position Indicator is not aligned with any of the positions	Rack-in or out the breaker to any of the distinct positions
ACB cannot be pushed into Disconnected position	Breaker & Cradle ratings donot match	Put correct breaker
Smart Racking Shutter does not open	"OFF" button not kept pressed fully	Keep OFF button pressed
	Door open/missing: hence Door Racking Interlock(26) is active	Clear/provide door; else press Door Racking Interlock lever (on extreme lower left side) manually
	Position lock(s) active	Unlock
ACB does not close electrically	Electrical antipumping is active	Interrupt 'Close' command once
	"Ready to close"(RTC) conditions are not met	Check all RTC conditions
ACB trips after closing	Overload fault exists if tripping is after several seconds or minutes. Other fault(s) exist if tripping is within a second	Press "QUERY" button on Protection&Control (P&C) Unit to confirm type of fault. Clear the cause of fault. Press "CLEAR" button on P&C Unit. Push back the red Reset Link
	(RED) reset link projects out	
	Shunt Release is getting command continuously	Check the source of command

Termination - Draw-out Breakers

Direct Aluminium termination

Frame-1 : 400 - 1600A N/S/H & 2000A N/S/H

Frame Size	Rating (A)	Aluminium cross section as per IS/IEC (in sq. mm)	Popular Aluminium Termination								
			Flat			Horizontal (with Terminal adaptor)			Vertical (with Terminal adaptor)		
			6 mm	10 mm	12 mm	6 mm	10 mm	12 mm	6 mm	10 mm	12 mm
1	800	800	75 - 2 runs	-	-	75 - 2 runs 50 - 3 runs	-	-	75 - 2 runs 50 - 3 runs	-	-
	1000	1000	60 - 3 runs	-	-	60 - 3 runs	50 - 2 runs	-	60 - 3 runs	50 - 2 runs	-
	1250	1512	-	-	63 - 2 runs	63 - 4 runs	-	63 - 2 runs	63 - 4 runs	-	63 - 2 runs
	1600	1600	-	60 - 3 runs	75 - 2 runs	-	60 - 3 runs	75 - 2 runs	-	60 - 3 runs	75 - 2 runs
	2000	3000	-	-	-	-	75 - 4 runs	-	-	75 - 4 runs	-

Note: Above table is based on extensive study of popular bus-bar sizes used to terminate Air Circuit Breakers. However other bus-bar sizes (in terms of thickness & width) can also be used to achieve bus-bar cross section recommended by IS & IEC. De-rating of switchgear depends upon various factors such as cross section area, orientation and material of bus bar, healthiness of bus-bar joints, panel construction, and ventilation, etc.

Frame-2 : 400 - 3200A N/S/H & 4000A S/H

Frame Size	Rating (A)	Aluminium cross section as per IS/IEC (in sq. mm)	Popular Aluminium Termination					
			Horizontal (with Terminal adaptor)			Vertical (with Terminal adaptor)		
			6 mm	10 mm	12 mm	6 mm	10 mm	12 mm
2	2500	4000	-	100 - 4 runs	-	-	100 - 4 runs	-
	3200	6000*	-	-	-	-	150 - 4 runs	-
	4000 [#]	7200*	-	-	100 - 6 runs	-	-	150 - 4 runs

For Fr-2 4000A, for Aluminum termination, first link **COPPER of 300mm** length (minimum) to be used.

Note: Above table is based on extensive study of popular bus-bar sizes used to terminate Air Circuit Breakers. However other bus-bar sizes (in terms of thickness & width) can also be used to achieve bus-bar cross section recommended by IS & IEC. De-rating of switchgear depends upon various factors such as cross section area, orientation and material of bus bar, healthiness of bus-bar joints, panel construction, and ventilation, etc.

Termination - Draw-out Breakers

Frame-3 : 400 - 4000A H/V & 5000-6300A H/V

Frame Size	Rating (A)	Aluminium cross section as per IS/IEC (in sq. mm)	Popular Aluminium Termination					
			Horizontal (with Terminal adaptor)			Vertical (with Terminal adaptor)		
			6 mm	10 mm	12 mm	6 mm	10 mm	12 mm
3	4000	7200*	-	150 - 5 runs	150 - 4 runs	-	125 - 6 runs	125 - 5 runs
	5000	8000*	Copper termination recommended					
	6300	10000*	Copper termination recommended					

*Not as per standard but generally followed

Note: Above table is based on extensive study of popular bus-bar sizes used to terminate Air Circuit Breakers. However other bus-bar sizes (in terms of thickness & width) can also be used to achieve bus-bar cross section recommended by IS & IEC. De-rating of switchgear depends upon various factors such as cross section area, orientation and material of bus bar, healthiness of bus-bar joints, panel construction, and ventilation, etc.

Direct Copper termination or Aluminium terminations with Copper jumpers

Frame-1 : 400 - 1600A N/S/H & 2000A N/S/H

(N1)

Frame Size	Rating (A)	Copper cross section as per IEC (in sq. mm)	Popular Copper Termination								
			Flat			Horizontal (with Terminal adaptor)			Vertical (with Terminal adaptor)		
			6 mm	10 mm	12 mm	6 mm	10 mm	12 mm	6 mm	10 mm	12 mm
1	800	500	-	60 - 1 run	-	-	50 - 1 run 60 - 1 run	-	-	50 - 1 run 60 - 1 run	-
	1000	600	-	60 - 1 run	-	-	60 - 1 run	-	-	60 - 1 run	-
	1250	800	75 - 2 runs	-	-	75 - 2 runs	-	-	75 - 2 runs	-	-
	1600	1000	60 - 3 runs	-	-	60 - 3 runs	-	-	60 - 3 runs	-	-
	2000	1500	-	-	-	-	75 - 2 runs	-	-	75 - 2 runs	-

Note: Above table is based on extensive study of popular bus-bar sizes used to terminate Air Circuit Breakers. However other bus-bar sizes (in terms of thickness & width) can also be used to achieve bus-bar cross section recommended by IS & IEC. De-rating of switchgear depends upon various factors such as cross section area, orientation and material of bus bar, healthiness of bus-bar joints, panel construction, and ventilation, etc.

Termination - Draw-out Breakers

Frame-2 : 400 - 3200A N/S/H & 4000A S/H

Frame Size	Rating (A)	Copper cross section as per IEC (in sq. mm)	Popular Copper Termination					
			Horizontal (with Terminal adaptor)			Vertical (with Terminal adaptor)		
			6 mm	10 mm	12 mm	6 mm	10 mm	12 mm
2	2500	2000	-	100 - 2 runs	-	-	100 - 2 runs	-
	3200	3200*	-	80 - 4 runs	-	-	80 - 4 runs	-
	4000	4000*	-	100 - 4 runs	-	-	100 - 4 runs 150 - 3 runs	-

Note: Above table is based on extensive study of popular bus-bar sizes used to terminate Air Circuit Breakers. However other bus-bar sizes (in terms of thickness & width) can also be used to achieve bus-bar cross section recommended by IS & IEC. De-rating of switchgear depends upon various factors Such as cross section area, orientation and material of bus bar, healthiness of bus-bar joints, panel construction, and ventilation, etc.

Frame-3 : 400 - 4000A H/V & 5000-6300A H/V

Frame Size	Rating (A)	Copper cross section as per IEC (in sq. mm)	Popular Copper Termination					
			Horizontal (with Terminal adaptor)			Vertical (with Terminal adaptor)		
			6 mm	10 mm	12 mm	6 mm	10 mm	12 mm
3	4000	4000*	-	100 - 4 runs	-	-	100 - 4 runs	-
	5000	6000*	Vertical termination recommended			-	100 - 6 runs	-
	6300	7200*	Vertical termination recommended			-	-	150 - 4 runs

*Not as per standard but generally followed

Note: Above table is based on extensive study of popular bus-bar sizes used to terminate Air Circuit Breakers. However other bus-bar sizes (in terms of thickness & width) can also be used to achieve bus-bar Cross section recommended by IS & IEC. De-rating of switchgear depends upon various factors Such as cross section area, orientation and material of bus bar, healthiness of bus-bar joints, panel construction, and ventilation, etc.

Termination - Draw-out Breakers

Temperature Derating of Ultra-Power ACBs

Current carrying capacity at different temperatures Ultra-Power ACBs

Can operate at higher temperatures than the reference Temperature of 40C as prescribed

In IS & IEC standards, under certain installation conditions. However in some cases current-carrying

Capacity needs to be reduced in order to follow temperature Rise limits and safe working conditions.

The table below shows the current carrying capacity Of ULTRA-POWER ACB's, where T = temperatures measured around the rear connections of the Air Circuit Breaker.

Current carrying capacity with copper bus-bars with orientation: Top - Vertical & Bottom - Vertical with adaptors

Frame size & current rating	Versions	Current carrying capacity at different temperature (T)				
		40°C	50°C	55°C	60°C	70°C
BU1-08	N	800	800	800	800	800
	N08/D10/S	800	800	800	800	800
	H	800	800	800	800	800
BU1-10	N	1000	1000	1000	1000	1000
	N08/D10/S	1000	1000	1000	1000	1000
	H	1000	1000	1000	1000	1000
BU1-12	N	1250	1250	1250	1250	1250
	N08/D10/S	1250	1250	1250	1250	1250
	H	1250	1250	1250	1250	1250
BU1-16	N	1600	1600	1530	1450	1360
	N08/D10/S	1600	1600	1600	1550	1460
	N08/H	1600	1600	1600	1600	1600
BU1-20	N	2000	2000	2000	2000	1800
	N08/D10/S	2000	2000	2000	2000	1890
	H	2000	2000	2000	2000	2000
BU2-25	N	2500	2500	2500	2500	2250
	S	2500	2500	2500	2500	2500
	N08/N10/H	2500	2500	2500	2500	2500
BU2-32	N/N08/N10/S/H	3200	3200	3200	3200	3050
BU2-40	S/H	4000	4000	3800	3600	3300
BU3-40	N08/H	4000	4000	4000	4000	3850
BU3-50	H	5000	5000	5000	5000	4770
BU3-63	V	6300	6130	5840	5540	5230

Please refer to Pages 113-115 to get the corresponding bus-bar cross section area required with different current rating of Air Circuit Breaker.

Note: The values indicated in the above tables are for general guideline for product selection. These values have been extrapolated from test data and theoretical calculations. They cannot replace practical industrial application or a temperature rise test. However de-rating of switchgear depends on others factors such as cross section area, orientation and material of bus-bar, healthiness of bus-bar joints, panel construction, and ventilation, etc.

Watt-loss Data of Ultra-Power ACB's

Watt loss value

Watt loss plays an important role in the electrical performance of Air Circuit Breaker. Factors like Overall dimension, rated current carrying capacity of Bus-bar and watt loss of apparatus attach To the Air Circuit Breaker also plays an important role in calculation of watt loss data. Total watt loss Value is measured at rated current (In) of a 3 pole Air Circuit Breaker at 50/60 Hz. ($W = 3 \times I_n^2 \times R$), where R is the resistance measured across the upper & lower terminals of ACB at cold state.

Frame Size & Current Rating	For draw-out ACB (Watt)			
	N	S	H	V
BU1-08	100	50	35	
BU1-10	160	65	50	
BU1-12	210	100	65	
BU1-16	325	160	100	
BU1-20	440	390	220	
BU2-25	560	560	465	
BU2-32	600	600	600	
BU2-40		770	770	
BU3-40			500	500
BU3-50			750	750
BU3-63			1000	1000

ULTRA POWER

Air Circuit Breakers

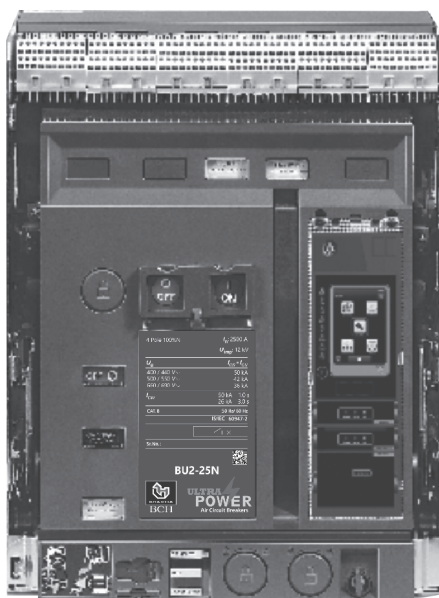

ULTRA POWER Range of Air Circuit Breakers

- Complete range conforms to IS/IEC 60947-2.
- Current rating from 800A to 5000A in 3 frame sizes.
- Available in 3 Pole & 4 Pole, Manually & Electrically operated, Fixed / Draw-out version.
- Common Height & Depth across the complete range.
- High short time fault withstand capacity, $I_{cu} = I_{cs} = I_{cw}$ for 1 sec for total selectivity.
- High mechanical and electrical operating life.
- Neutral pole is 100% rated.
- In-built Electrical & Mechanical Anti - Pumping.
- Modular & snap-fit accessories.
- Ease of on-site conversion from Fixed to Draw-out version.
- Pollution Degree 4 suitability.
- Best in Class Overlap with Bus bars.
- Break Time of 25msec.
- RoHS Compliant.

Breaking Capacities:

$$I_{cu} = I_{cs} = I_{cw}$$

Rated current	800A	1000A	1250A	1600A	2000A	2500A	3200A	4000A	5000A
N : 50kA									
S : 65kA									
H : 80kA									
V : 100kA									
	BU1-08	BU1-10	BU1-12	BU1-16	BU1-20	BU2-25	BU2-32	BU2-40	BU3-50
	Frame-1					Frame-2			Frame-3

BU 1 08 N X D 1 2 9 0 0

BU1 800N 3P ED 1.5G BotV

Frame Size	
Frame - I	1
Frame - II	2
Frame - III	3

Current Ratings	
400A	04
630A	06
800A	08
1000A	10
1250A	12
1600A	16
2000A	20
2500A ⁽⁴⁾	25
3200A	32
4000A	40
5000A	50

Type	
Manually Operated	1
Electrically Operated	2

Selection for Termination (For Drawout ACBs Only)	
Standard Termination	0
For Top Horizontal (Long), Bottom Vertical for Fr2 & Fr3	X
For Top & Bottom Horizontal (Long) for Fr3	Y
Note: X is applicable for 4000A (Fr2 & Fr3) and 5000A (Fr3). Y is applicable for 4000A (Fr3) & 5000A (Fr3) X & Y recommended for Buscoupler only.	

Temperature Rise Monitoring ⁽³⁾	
Not Required	0
Required	1

Selection for P&C Units	
B/C (w/o protection)	0
BU - BTX1.0	7
BU - BTX1G	8
BU - BTX1Gi	B
BU - BTX1.5G	9
BU - BTX1.5Gi	C
BU - BTX3.5	3
BU - BTX4.5	5
BU - BTX3.5H	6

Selection for control voltage ⁽²⁾	
For Manually Operated	0
240V AC ECD & CR & 240V AC SR	1
240V AC ECD & CR & 24V DC SR	2

Version	
Draw-out	D
Fixed	F

Selection for No. of Poles	
3 Pole	X
4 Pole 100% N	F

Selection for Breaking Capacity (I _{cu} =I _{cs}) ⁽¹⁾	
50kA (Fr-I upto 2000A & Fr-2 upto 3200A)	N
65kA (Fr-I & Fr-II)	S
80kA (Fr-II & Fr-III)	H
100kA (Fr-III)	V

- Please Note :** (1) For I_{cu} values please refer product catalogue
 (2) Other options of control voltage are available as accessory
 (3) Temperature protection is available in BU-BTX3.5/3.5H/4.5
 (4) For Fr-1, 2500A selection, please contact the nearest branch

ACBs are offered with following standard features:

Draw-out Version: Ultra power ACBs with BU-BTX release will have inbuilt Current Metering (BTX 1.5G/1.5Gi/3.5/3.5H/4.5), Common Fault Indication microswitch, 4NO+4NC Aux. contacts, Smart-racking, Shutter, Safety shutter assembly, Racking handle, Door sealing frame, Pad-locking arrangement for ON/OFF button, Rating Error Preventer, Arc shield.
 A) For ratings upto 1600A, one side vertical terminal adaptors (Bottom) for Frames 1.
 B) For ratings 2000A & above, both side vertical terminal adaptors (Top & Bottom) for Frames 1, 2 & 3.
 C) For rating 4000A and above operation counter inbuilt for Frames 2 & 3 both.

Fixed Version: Ultra power ACBs with BU-BTX release will have inbuilt- Current Metering (1.5G/1.5Gi/3.5/3.5H/4.5), Common Fault Indication microswitch, 4NO+4NC Aux. contacts, Door sealing frame & Pad-locking arrangement for ON/OFF push but
 A) For ratings upto 1600A, one side vertical terminal adaptors (Bottom) for Frame 1, 2 & 3.
 B) For ratings 2000A & above, both side vertical terminal adaptors (Top & Bottom) for Frames 1, 2 & 3.
 C) For rating 4000A and above operation counter inbuilt for Frames 2 & 3 both.
 Electrically operated ACB includes ECD (240V AC), CR (240V AC) & SR (240V AC OR 24V DC).

- Power Control Products
- Starters & Submersible Pump Starters
- Industrial Enclosures
- Industrial Products
- Wires & Cables
- Motor Control Products
- Power Bus Duct
- Customised Solution
- Automation

a strong commitment to serve better, a way's ...



BCH ELECTRIC LIMITED



www.bchindia.com

Visit us at : www.bchindia.com

Corporate Office : 1105, New Delhi House, 27, Barakhamba Road, New Delhi-110 001 Tel. : 91-11- 43673100

CIN : U31103WB1965PLC026427, **Customercare No.** 1800-103-9262, **E-mail :** marketing@bchindia.com

Registered Office : Block 1E, 216, Acharya Jagadish Chandra Bose Road, Kolkata - 700 017

Works 1 : 20/4, Mathura Road, Faridabad -121 006 (Haryana) Tel. : 0129-4063000/4293000 Fax : 0129-2304016

Works 2 : 64-68, Sector-7, IIE, Pant Nagar, Rudrapur, Udham Singh Nagar - 263 153 (Uttarakhand) Tel. : 05944-250214/16 Fax : 05944-250215



1800-103-9262

customercare@bchindia.com

Sales Offices :

Ahmedabad
401, Ship Zeveri,,
Beside Shyamal Iconic,
Above Westside,
Shyamal Cross Road,
Ellis bridge, Ahmedabad - 380015
E-mail: ahmedabad@bchindia.com

Bangalore
2nd Floor, 130/5,
K.H. Road (Double road),
Bangalore - 560 027
Tel.:080-41144879 / 22236759
E-mail : bangalore@bchindia.com

Bhubaneswar
Mallick Commercial
Complex Plot No.: A/69, unit - 3
Bhubaneswar - 751 001
Tel.: 0674-2380988
E-mail: bhubaneswar@bchindia.com

Chandigarh (Panchkula)
SCO -129, 2nd Floor,
MDC, Sector-5 Panchkula,
Haryana-134 114
Tel.: 0172-5078957 / 5049905
E-mail: chandigarh@bchindia.com

Chennai
Flat No. 3A, 3rd Floor,
Sree Apartments,
No.508, TTK Road,
Alwarpet, Chennai 600 018
Tel.: 044-24337046, 24337047
E-mail : chennai@bchindia.com

Coimbatore
87, Dr. Nanjappa Road,
Coimbatore - 641 018
Tel. : 0422-2305311 / 2302599
E-mail : coimbatore@bchindia.com

Delhi 1
801, Akash Deep Building,
26A, Barakhamba Road,
New Delhi - 110 001
Tel. : 011-23313878 / 43518200
E-mail : delhi@bchindia.com

Delhi 2
710, Deepali Building, 92
Nehru Place, New Delhi - 110 019
Tel. : 011-45720334
E-mail : delhi2@bchindia.com

Dehradun
8, Co-operative Industrial Estate,
Patel Nagar, Dehradun-248001
E-mail : dehradun@bchindia.com

Faridabad
20/4, Mathura Road,
Faridabad - 121 006 (Haryana)
Tel.: 0129-4293009
E-mail : faridabad@bchindia.com

Hyderabad
1-8-303/48/13/102, Arya One,
2nd Floor, P. G. Road,
Secunderabad - 500 003
Tel. : 040-66206263/27890306
Fax : 040-66207273
E-mail : hyderabad@bchindia.com

Indore
330-331, Indraprastha Tower,
3rd Floor, 6, M.G. Road,
Indore - 452 001
Tel. : 0731-2510011 / 2510012
E-mail : indore@bchindia.com

Jaipur
25, Hathroi, Gopalbari,
Jaipur - 302 001
Tel. : 0141-2363521
E-mail : jaipur@bchindia.com

Jamshedpur
3rd Floor, Aastha Trade Centre,
'Q' Road, Bistupur,
Jamshedpur - 831 001
Tel. : 0657-2321097/2321481
E-mail : jamshedpur@bchindia.com

Kolkata
Block 1E, 216,
Acharya Jagadish Chandra Bose Road,
Kolkata - 700 017
Tel. : 033-22871728 / 46021884
E-mail : kolkata@bchindia.com

Lucknow
Madan Plaza, 3rd Floor,
14, Station Road,
Lucknow - 226 001
Tel. : 0522-4025597/4025997
E-mail : lucknow@bchindia.com

Ludhiana
S.C.O.- 18, 2nd Floor,
Feroze Gandhi Market,
Ludhiana - 140 001
Tel. : 0161-5021807/5022808
E-mail : ludhiana@bchindia.com

Mumbai
A-151, Mittal Tower,
Nariman Point,
Mumbai - 400 021
Tel. : 022-22822947/22850162
Fax : 022-22822858
E-mail : mumbai@bchindia.com

Pune
8, Sarosh Bhavan,
16-B/1, Dr. Ambedkar Road,
Pune - 411 001
Tel. : 020-41210002
E-mail : pune@bchindia.com

Raipur
6th Floor, Office No. 607,
Babylon Capital, Near Oswal
Petrol Pump, VIP Chowk,
G.E. Road, Raipur - 492 006
Tel. : 0771- 4045053
E-mail : raipur@bchindia.com

Trichy
2B, Kannagi Street,
Ayyappa Nagar, K.K.Nagar
Trichy - 620 021, Tamilnadu
Tel. : 0431-4040497
E-mail: trichy@bchindia.com

Vadodara
301, Third Floor, "Florence Classic",
10, Ashapuri Co-Op. Hsg. Soc. Ltd., Opp. VUDA Housing,
Near Cow Circle, Akota, Vadodara - 390 020
Tel. : 0265-2345068/2345069
Telefax : 0265-2345068,
E-mail : vadodara@bchindia.com

Other Branch Locations

Cochin : cochin@bchindia.com, **Guwahati** : guwahati@bchindia.com, **Vishakapatnam** : vizag@bchindia.com, **Surat** : surat@bchindia.com

Resident Engineer Locations

Anantapur	Kanpur	Nashik	Salem	Yamunanagar
Bhopal	Katni	Patna	Siliguri	
Calicut	Karimnagar	Puducherry	Surat	
Gurgaon	Kota	Rajkot	Tirunelveli	
Jalandhar	Midnapur	Ranchi	Udaipur	
Jalgaon	Muzaffarnagar	Rourkela	Vapi	
Jodhpur	Nagpur	Rudrapur	Vijayawada	

Since product improvement is a continuous process, the data furnished in this brochure may undergo revision without prior notice.